



# DEHUMIDIFIERS

NE Series

NP Series

NH Series

NW Series

CWT Series

INSTALLATION MANUAL

[SerescoDehumidifiers.com](http://SerescoDehumidifiers.com)

# Table of Contents

<b>General Information .....</b>	<b>2</b>
Operating Safety (Warnings, Cautions, and Notes) .....	2
Reference and Additional Information.....	3
<b>Delivery and Storage.....</b>	<b>4</b>
Receiving Checklist .....	4
Shipping Damage Handling .....	4
Storage.....	5
<b>Mechanical Installation .....</b>	<b>6</b>
Lifting and Rigging .....	6
General Mechanical Installation Requirements.....	7
General Placement of the Equipment.....	7
Outdoor Condenser (OACC) and Fluid Cooler (O AFC) Mechanical Installation.....	10
Mechanical Installation – Special Cases .....	14
<b>Ductwork Connection.....</b>	<b>17</b>
Ductwork Layout Considerations .....	17
Duct Connection – General Considerations.....	18
Duct Connection – Special Cases .....	18
<b>Piping Connection.....</b>	<b>19</b>
Piping Connection General Considerations.....	19
Condensate Drain Connection and P-trap Installation .....	20
Pool Water Heating Piping.....	21
Outdoor Air Condenser Piping (NC models).....	22
Fluid Cooler Piping (NG models) .....	25
Other Piping Systems and Special Cases .....	27
<b>Electric Connection: power, control and communication.....</b>	<b>30</b>
Electrical Connection - General Considerations .....	30
Equipment Main Power Connection .....	30
Outdoor Air Condenser and Fluid Cooler Power and Control Connection .....	31
Field Wiring – External Control and Communication .....	31
Field Wiring – Special Cases .....	35

## General Information

This manual provides basic information about various installation aspects of the applicable equipment and its additional and auxiliary systems and devices.

- This manual covers installation details of the equipment of various design, size, capacity etc.; therefore, some details covered in this manual may not be relevant to each piece of equipment. Refer to your equipment's submittal documentation.

Important information regarding operation, maintenance, and start up is normally provided with the equipment and can also be obtained from the manufacturer – contact Customer Support Team as needed (see **Reference and Additional Information** on the following page).

## Operating Safety (Warnings, Cautions, and Notes)

**FOR YOUR SAFETY: READ BEFORE PERFORMING ANY INSTALLATION OR OTHER TASKS!**



Only qualified technicians should install, operate, maintain or service mechanical equipment including this dehumidification system.

Make sure to read this manual before performing any installation tasks to familiarize yourself with the equipment as well as with any potential hazards. Always exercise caution!



### **Beware of high pressures and chemicals!**

- Dehumidifiers, equipped with compressors, contain refrigerant under high pressure; oil is also contained in the compressor and refrigeration circuit(s)
- Some dehumidifiers may also contain other liquids such as glycol mixtures and pool water

The following warnings, cautions, and notes appear throughout this manual and referenced documentation whenever special care must be taken to avoid potential hazards that could result in equipment malfunction or damage, personal injury, or death.



### **WARNING**

Indicates a potentially hazardous situation which could result in serious injury or death if handled improperly.



### **CAUTION**

Indicates a potentially hazardous situation which could result in moderate injury or equipment damage if handled improperly.

### **Note**

Indicates a situation that could result in equipment damage or improper/ ineffective operation if handled improperly.

## Reference and Additional Information

For safe, efficient and problem-free operation, it is critical to handle the dehumidifier (as well as related systems and components) properly at each step - from receiving and storage to installation and start up. Relevant information can be found in the respective documents (**Operation and Maintenance Manual, Start Up Package**, etc.) provided with the dehumidifier. This manual as well as other related documents can be obtained from the manufacturer (see **Contact Us** below).

## Warranty

The manufacturer standard warranty statement can be found in the **Operation and Maintenance Manual**, provided with the equipment.

### Attention: Warranty Conditions and Coverage.

**NOTE.** The equipment is provided with comprehensive conditional warranty coverage. Any warranty work to be reimbursed must be approved by **Service & Customer Support Team** prior to work commencing. Installation, start up, maintenance etc. are not within warranty scope. Refer to the manufacturer standard warranty statement for more details on warranty conditions, scope and coverage.

### Attention: Equipment Proper Usage.

 **CAUTION!** Dehumidifier is **NOT** intended, and, therefore, **NOT** to be used, to condition (heat, cool, ventilate etc.) premise that is ***still under construction***. Such usage may cause equipment premature wear, poor performance and potential failure afterwards and will void the warranty!

mechanical equipment (dehumidifier, outdoor condenser, fluid cooler, etc.) must be performed in accordance with respective manufacturer recommendations as well as submittal documentation, local Codes and Regulations, and appropriate field practices. Failure to do so could result in personal injury, equipment damage or malfunction, and will void equipment warranty. Only qualified and properly trained individuals should perform tasks on this equipment.

## Contact Us

Seresco  
5685 Cypihot Street  
Saint Laurent, QC H4S 1R3  
Canada

[SerescoDehumidifiers.com](http://SerescoDehumidifiers.com)

1-833-DAS-POOL (327-7665)

Schedule / Modify a Start-up:  
[Scheduling@DehumidifiedAirServices.com](mailto:Scheduling@DehumidifiedAirServices.com)

Inquire about Warranty:  
[Warranty@DehumidifiedAirServices.com](mailto:Warranty@DehumidifiedAirServices.com)

Order Parts:  
[Parts@DehumidifiedAirServices.com](mailto:Parts@DehumidifiedAirServices.com)

All Other Product Support:  
[Support@DehumidifiedAirServices.com](mailto:Support@DehumidifiedAirServices.com)

## Delivery and Storage.

### Receiving Checklist

Each piece of equipment is tested and inspected before it ships from the factory; however, the equipment may suffer damage in transit.

It is highly recommended to thoroughly check for both visible and concealed damage upon the equipment arrival and before signing the receiving papers:

- ✓ Visually inspect exterior of the equipment for damages (scratches, dents, missing elements, etc.)
- ✓ Verify the proper operation of latches and hinges on all access doors
- ✓ Inspect all coils for damage to the fin surface coating, headers or coil connections
- ✓ Manually rotate the fan wheel to ensure free movement of the shaft, bearings, and drive
- ✓ Inspect the fan housings for any foreign objects
- ✓ Inspect and test all piping for possible shipping damage
- ✓ Check the tightness of bolts on the fan structure and coils
- ✓ Inspect fan isolator shipping brackets

### Shipping Damage Handling

Default manufacturer shipping method is “freight on board” (FOB), meaning that the equipment belongs to the customer as soon as the delivery truck leaves the factory.

**Note:** Manufacturer is not responsible for any shipping damage. Should the equipment arrive damaged, follow the instructions below to resolve the situation. Delivery cannot be refused on the basis of shipping damage.

#### Shipping Damage Handling Instructions:

- ✓ Note the damage in detail on the freight bill and bill of lading.
- ✓ Take clear photographs of the damaged components, areas, and portions of the equipment.
- ✓ Obtain a claim form from the carrier, fill it out, and return it promptly. Report all claims of shipping damage to the carrier immediately and coordinate a carrier inspection if necessary.
- ✓ Contact Customer Support Team (see **Contact Us** above) to notify of the noted damage.
  - Have the equipment serial number (8-digit) on hand to provide to Customer Support Team. The serial number can be found on the equipment’s main label or bill of lading.
  - Note: it is the receiver's responsibility to provide reasonable evidence that damage was not incurred after delivery.
  - Do not attempt to repair the equipment without consulting with Customer Support Team.

## Storage

- Protection from the elements is required for any equipment that will be stored on a job site or holding area before installation.
- For long-term storage, a controlled indoor environment is highly recommended.
- All factory-applied shipping protection should be removed before the equipment is put into storage. Shipping protection material is provided by the factory for shipping only – it is not a suitable protection for short or long-term storage.
- If long-term storage is required, warranty aspect should be considered - refer to the **Warranty** section of **Operation and Maintenance Manual** for more details regarding standard warranty terms and conditions. Contact manufacturer if needed.

## Mechanical Installation

**⚠️ WARNING!** All work must be done by qualified personnel in accordance with local and national Codes, Standards and Regulations as well as respective submittal documentation and manufacturer recommendations.

**⚠️ CAUTION!** Obtain all necessary documentation (manufacturer documentation, submittal documentation, drawings, etc.) and familiarise yourself with it before performing installation or any other related tasks.

## Lifting and Rigging

**⚠️ WARNING!** Lifting and rigging must be done by trained professionals in accordance with proper lifting techniques and safety procedures. Proper lifting machinery and tools and safety equipment (PPE) must be used. Improper lifting may cause equipment damage, serious injury, or death. Manufacturer is not responsible for the improper use of lifting equipment.

- ✓ Use spreader bars for lifting to prevent equipment damage. Use cables (chains or slings) as shown on Pic. E.1.
  - Use dehumidifier lifting brackets at the base frame.
- ✓ Each of the lifting cables (chains or slings) must be capable to support the entire weight of the equipment.
- ✓ Determine the approximate centre of gravity before lifting. See equipment design drawings in the submittal documents for the total weight and weight distribution.
- ✓ Lifting cables (chains or slings) may not be of the same length. Adjust as necessary for an even lift.
- ✓ Do not lift equipment in windy conditions.
- ✓ Do not raise equipment overhead with personnel below.
- ✓ Test lift the equipment 24 inches to verify proper operation of lifting machinery and positioning of lift points such that the lifted equipment is level.
- ✓ To avoid damage, do not attach intake or exhaust hoods prior to lifting

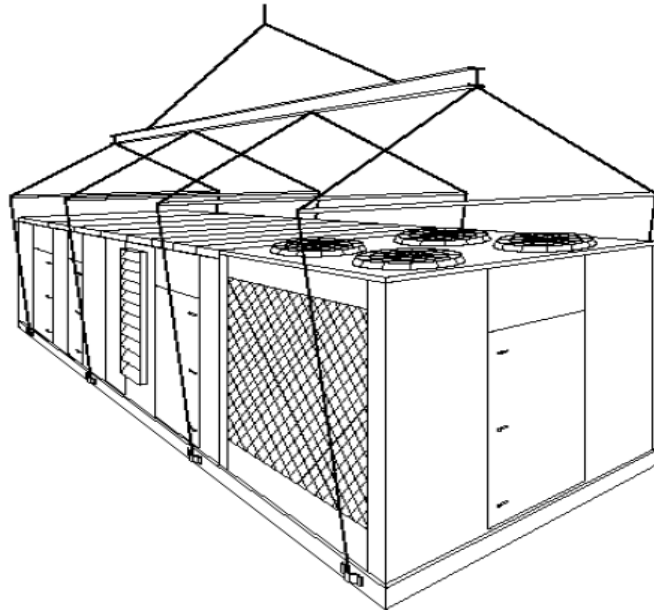

Pic. E.1

### “Split-Cut” Dehumidifier Lifting

Some dehumidifiers may, if requested, be shipped in sections to be assembled on site.

- ✓ **Never assemble split sections before lifting them to the installation location.**
  - Always lift sections separately, as received from the factory.
- ✓ Lift each section using its lifting lugs/brackets.

## General Mechanical Installation Requirements

Equipment (dehumidifier, outdoor condenser, fluid cooler, etc.) should be installed in accordance with respective local Codes and Regulations as well as applicable submittal documentation. There are several general key installation points:

### General Placement of the Equipment

- ✓ Equipment must be installed on a firm, levelled surface, with provision for vibration absorption.
- ✓ **Service and operational clearances** to the equipment must be always maintained.
  - Access to ALL doors, louvers, filter racks, access ports and covers must not be restricted. Some installations may require cat-walks (over ducts, pipes, etc.) or other means of access to otherwise restricted side of the equipment.
  - **Dehumidifier:** may require **up to 36"** clearance for proper operation, service and maintenance;
  - **Outdoor Condenser (OACC)/Fluid Cooler (O AFC):** may require **up to 36"** clearance all around and **up to 96"** clearance above fan for proper operation, service, and maintenance.
    - Avoid **installing OACC/O AFC in a pit**, where it's surrounded on all four sides by walls, structures, etc. If such an installation cannot be avoided, the following must be maintained:
      - the min. clearances must be increased to double width of the OACC/O AFC all around;
      - surrounding structures' height must not exceed the height of the OACC/O AFC.

**NOTE.** For equipment-specific data (dimensions, clearances, accessibility, etc.) refer to equipment submittal documentation, Operation and Maintenance Manual, and equipment labels and stickers.

### Indoor Dehumidifier Installation (dehumidifier, installed in mechanical room)

- ✓ No chemicals allowed to be stored in the same mechanical room;
  - other stored materials must not block access to the equipment for service and maintenance.
- ✓ Mechanical room must have operational floor drain.
- ✓ **Ceiling-suspended** installation: support dehumidifier from (underneath) the base; refer to submittal documentation for dehumidifier weight distribution for proper selection and positioning of support.
- ✓ **Outdoor Air (OA) intake box.** Some dehumidifiers with outdoor intake option, may have an OA intake box, mounted onto the OA intake opening or provided separately to be field-installed. If latter is the case:
  - install box over the OA opening, attach it to the dehumidifier with provided self-tapping screws.



- Attach OA duct to the box (see **Ductwork Connection** chapter).
- **Control/electrical contractor:** connect control wire harness to the OA box devices (actuators, sensor etc.) inside the junction box (see Pic. E.2) – follow the junction box legend and dehumidifier wiring diagram.

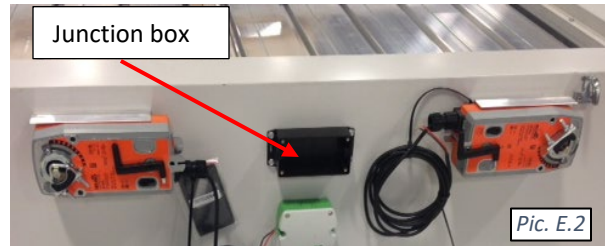

### Outdoor Dehumidifier Installation

- ✓ **Roof Curb.** If the dehumidifier is installed on a roof curb, it must utilize curb gasket material (to create a moisture and weather seal between the dehumidifier and a roof curb).
  - **ATTENTION!** Before placing onto a roof curb, consider accessibility underneath the dehumidifier for various mechanical and electrical systems connections (power, drain, other piping, etc.)
  - **ATTENTION!** It is **not** recommended to use space within a roof curb as a supply or return duct.
- ✓ Consider the direction of strong prevailing winds – it may negatively affect equipment operation (cross-flow of exhausted and fresh air and/or flue gases, elements (rain, snow) aspiration into the OA opening, etc.)

### Outdoor Dehumidifier – Louvers Installation

To protect outdoor-installed dehumidifier openings (outdoor air intake, exhaust air discharge, etc.) against elements, louvers are installed or provided separately for field installation. If latter is the case:

- ✓ Uncrate/unwrap provided louver and place it over respective opening/damper (Pic. E.3):
  - Larger louvers require two persons to lift and place the louver
  - Dehumidifier with larger louvers also have louver support lip over the damper.
- ✓ Adjust louver position – shift it slightly left or right as needed to ensure louver side walls and access panels do not interfere with damper linkage, actuators, filter racks, sensors, etc.
- ✓ Once the louver is positioned properly, attach it to the dehumidifier with the provided self-tapping screws on all four sides. If access panels were removed for louver installation, reattach the panels and close the latch.

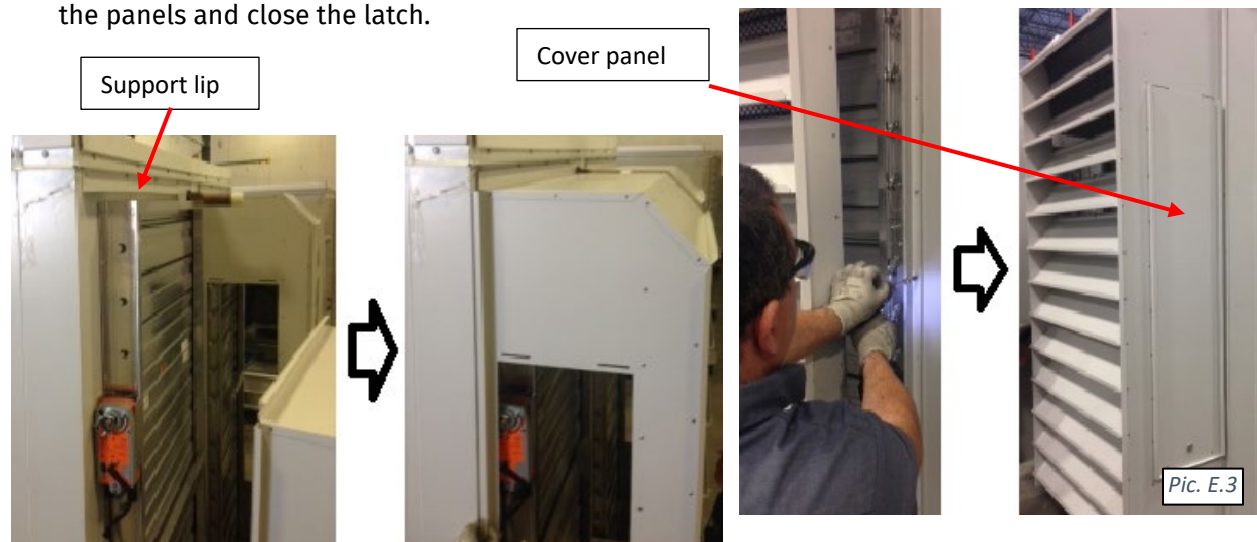

## Outdoor AND Indoor Dehumidifier - Field-installed OA (outdoor air intake) Filter Rack Installation

If the Outdoor Air intake (OA) filter rack is shipped separately, it should be attached to respective opening/damper once dehumidifier is installed. *This may apply to both, indoor and outdoor installed dehumidifiers.*

- ✓ Attach filter rack to the damper with provided self-tapping screws; position rack as shown on Pic. E.4.
- ✓ Once the rack is installed, insert/install OA sensor (thermistors or combo sensor, as shown in the picture) between the damper and the filters; ensure that the sensor will not interfere with the damper blades motion.

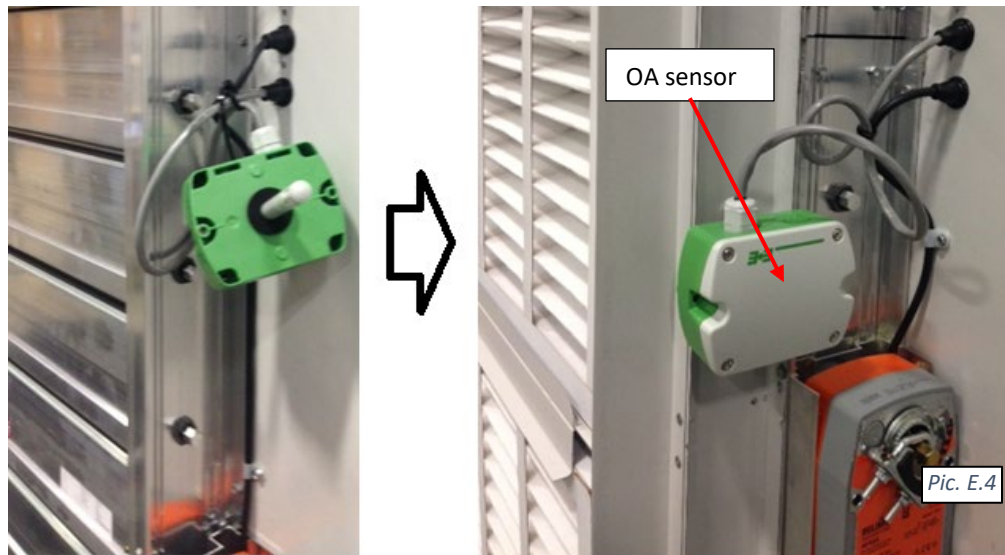

## Outdoor Dehumidifier – Outdoor Air and Exhaust “Door/Louver” Assembly Installation

For shipping purposes, the OA and Exhaust Louver(s) may be shipped on the top of the dehumidifier and will require field installation (see Pic. E.5). *This normally applies to outdoor NE004-NE008 series dehumidifiers.*

- ✓ Remove the door/louver assembly (a) from the roof and place it in front of the respective opening; normally, the air damper with pre-wired actuator is mounted within the louver – use caution not to damage wiring.
  - The OA door/louver assembly is normally placed on the roof near/above OA opening. The Exhaust door/louver assembly, respectively – near/above Exhaust opening.
- ✓ Release louver latches (b) on both sides to open the louver and access bolts (c) later;
- ✓ Place door support brackets (d) on the dehumidifier floor into the opening,
- ✓ Lift the door and place it, then tighten bolts (c) to secure the door.
  - OA damper would also have a filter rack, attached to it.

- ✓ Lift the hood in place and lock the latches (b).

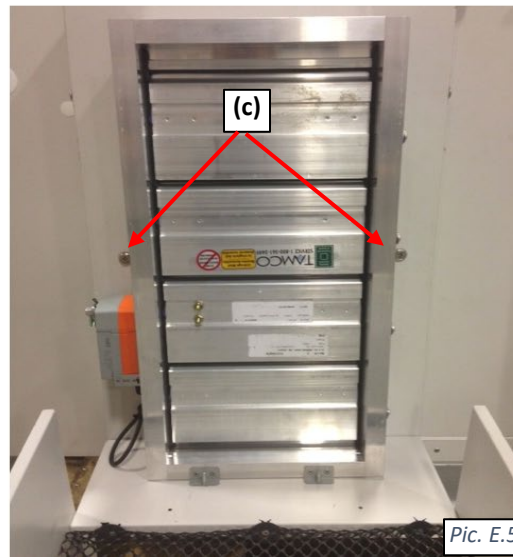
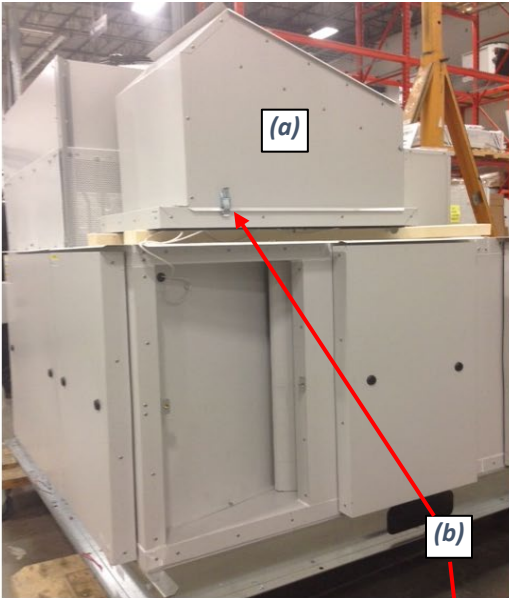

## Outdoor Condenser (OACC) and Fluid Cooler (O AFC) Mechanical Installation

The requirements outlined in **General Placement of the Equipment** (see above) apply to all models of OACC/O AFC.

- ✓ It is recommended to **anchor** light-weighted OACC/O AFC to the horizontal mounted surface (concrete pad etc.). This applies to **all OACC** models and **some O AFC** models (NG-Z and NG-V-01, -02, -11 and -12).

**NOTE.** Do NOT exceed distance limitation between the dehumidifier and OACC or OAFC – it may result in equipment incorrect operation and/or failure. Before finalizing OACC or OAFC placement/location, refer to respective dehumidifier main label, as well as submittal documentation and **Fluid Cooler Piping** and **Outdoor Condenser Piping** chapters of current manual (see further). Contact the factory if needed.

### Outdoor Condensers and Fluid Coolers Field Assembly – models NC-Z, NC-B and NG-Z.

The NC-Z and NC-B Series outdoor condensers can be provided in vertical or horizontal airflow configuration and may require field assembly of respective mounting support:

**Vertical airflow configuration (equipment is mounted on a horizontal surface such as ground, roof, etc.):**

- ✓ OACC model **NC-Z** and OAFC model **NG-Z** assembly is shown on Pic. E.7A below:
  - Uncrate/unwrap the equipment and legs.
  - Install the four provided legs (a) onto the equipment (leg is to be placed inside in the corner)
    - Double condenser/cooler (b) would have six legs provided – place two additional legs in the middle – refer to picture.
  - Align all four holes in each leg and equipment corner and attach legs with provided bolts, washers (legs have factory-installed nut-certs); tighten all bolts.
  - Ensure that the equipment is levelled and firm; affix the legs to the surface (concrete slab, etc.); anchors/fasteners for surface mounting are NOT included.

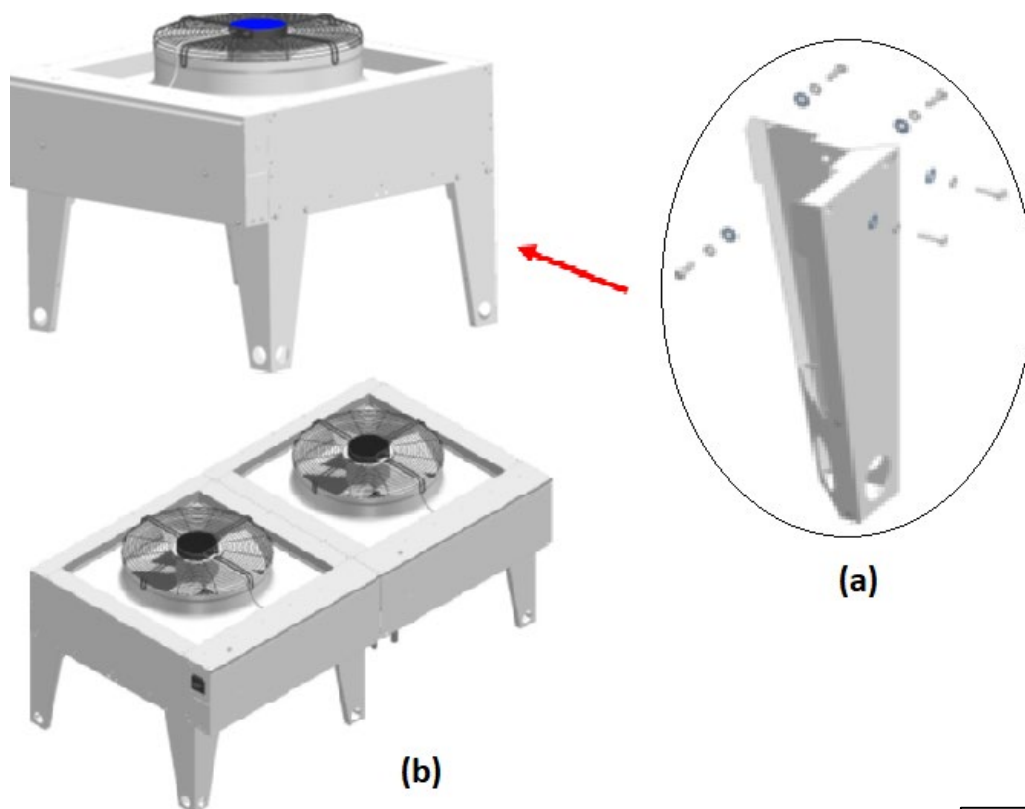

Pic. E.7A

- ✓ OACC model **NC-B** assembly is shown on Pic. E.7B below:
  - Uncrate/unwrap the condenser and mounting kit.
  - Assemble left and right mount legs as shown with provided bolts, nuts, and washers (except for joint point (a) – it must be bolted to the condenser)

- Align holes (a) and (b) in the mount legs with the holes in the condenser and attach them with provided bolts, nuts and washers.
- Attach rear support braces to the condenser with provided self-tapping screws (c)
- Install the optional front cross piece (d) between left and right leg with provided bolts, nuts and washers;
- Ensure that the assembly is straight, square and sturdy; tighten all bolts.
- Ensure that the condenser is levelled and firm; affix mount legs footings to the surface (concrete slab, etc.); anchors/fasteners for surface mounting are NOT included.

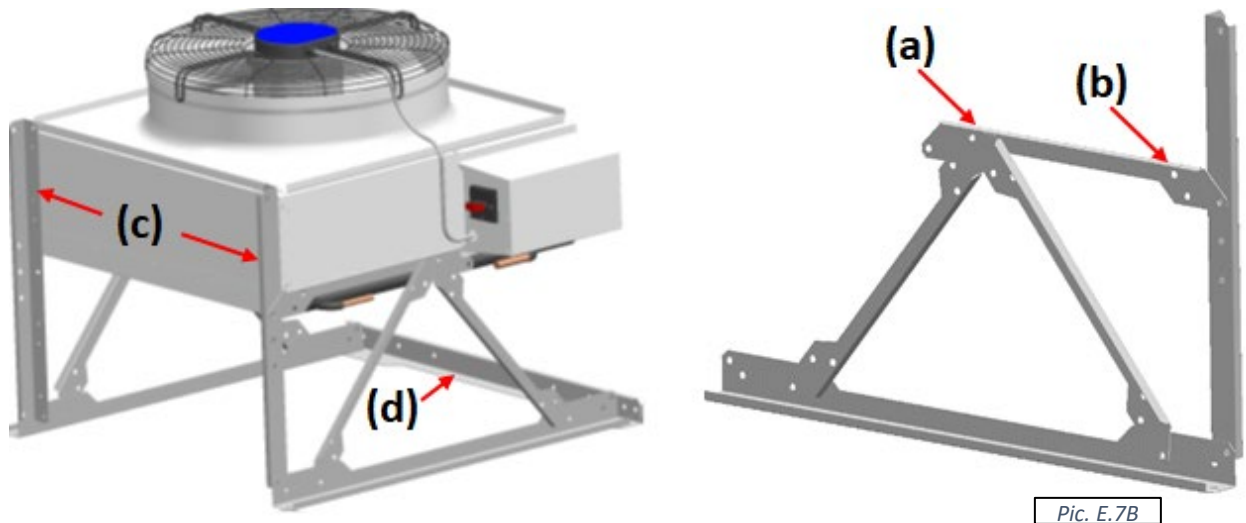

Pic. E.7B

**Horizontal airflow configuration** (equipment is mounted on a vertical surface such as a wall.). In this case, use the same mount kit as above. Note that the mount legs are assembled slightly differently.

- OACC model **NC-Z** and **NC-B** assembly is shown on Pic. E.7C below:
  - Uncrate/unwrap the equipment and mounting kit.
  - Assemble left and right mount legs as shown with provided bolts, nuts, and washers (except for joint point (a) – it must be bolted to the condenser/cooler)
    - Note that the cross-piece (b), that is to be attached to the equipment, is mounted differently for NC-Z and NC-B.
  - Before final assembly of equipment and mount legs, ensure following:
    - For Outdoor Condenser **NC-B**: electric box is positioned as shown – horizontal, with drip protection bend (c) at the top;
    - For all Outdoor Condensers (**NC-Z** and **NC-B**): refrigerant connections are on the side AND liquid line connection (refer to condenser labels) is the bottom one, (e).
  - Align respective holes in cross-piece (b) and the holes in the equipment and attach them with provided bolts, nuts, and washers.
  - Attach rear support braces to the condenser with provided self-tapping screws (d)
  - Ensure that the assembly is straight, square, and sturdy; tighten all bolts.
  - Ensure that the condenser is levelled and firm; affix mount legs footings to the surface (wall, etc.); anchors/fasteners for surface mounting are NOT included.

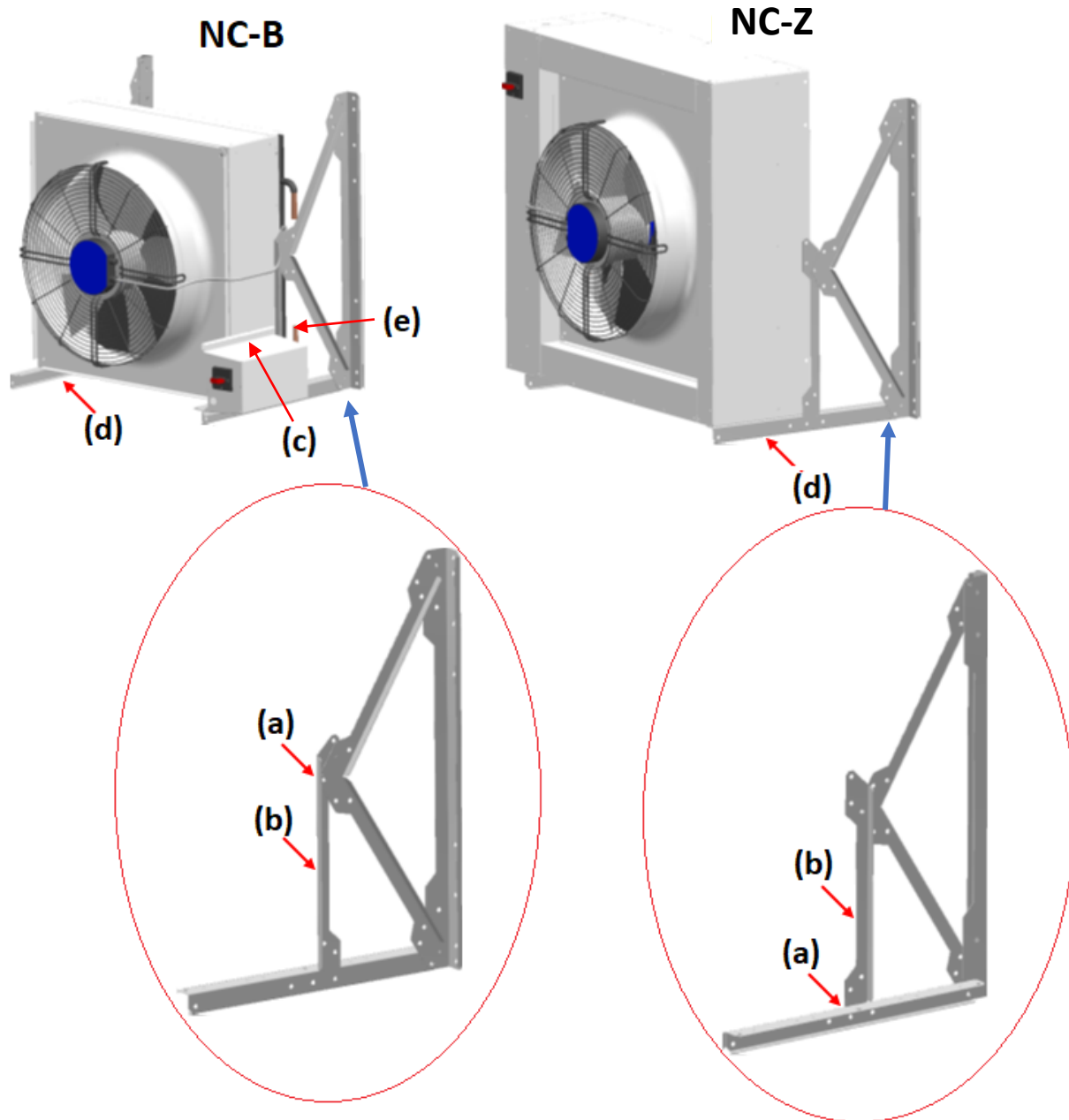

Pic. E.7C

**ATTENTION! Cooling Fluid Lines Sweating!**

Under certain conditions (namely – when the cooling fluid lines’ outer surface drops below dew point of the surrounding air, particularly inside the facility), said lines may “sweat” as condensation forms on their surface. Should this occur, it is recommended to insulate the piping to prevent condensation.

## Mechanical Installation – Special Cases

Some equipment may have additional/optional arrangements – refer to submittal documentation and equipment accompanying factory instructions.

### Frame-mounted main blower shipping brackets.

For shipping purposes, larger (7 HP and up) direct-driven main blower frame springs are affixed with shipping brackets (see Pic. E.8). *This normally applies to NP series dehumidifiers only.*

- Upon installation remove ONLY lower bolt from all four corners (detail A) at the frame base - removing these bolts ensures that the blower vibration is dampened correctly.

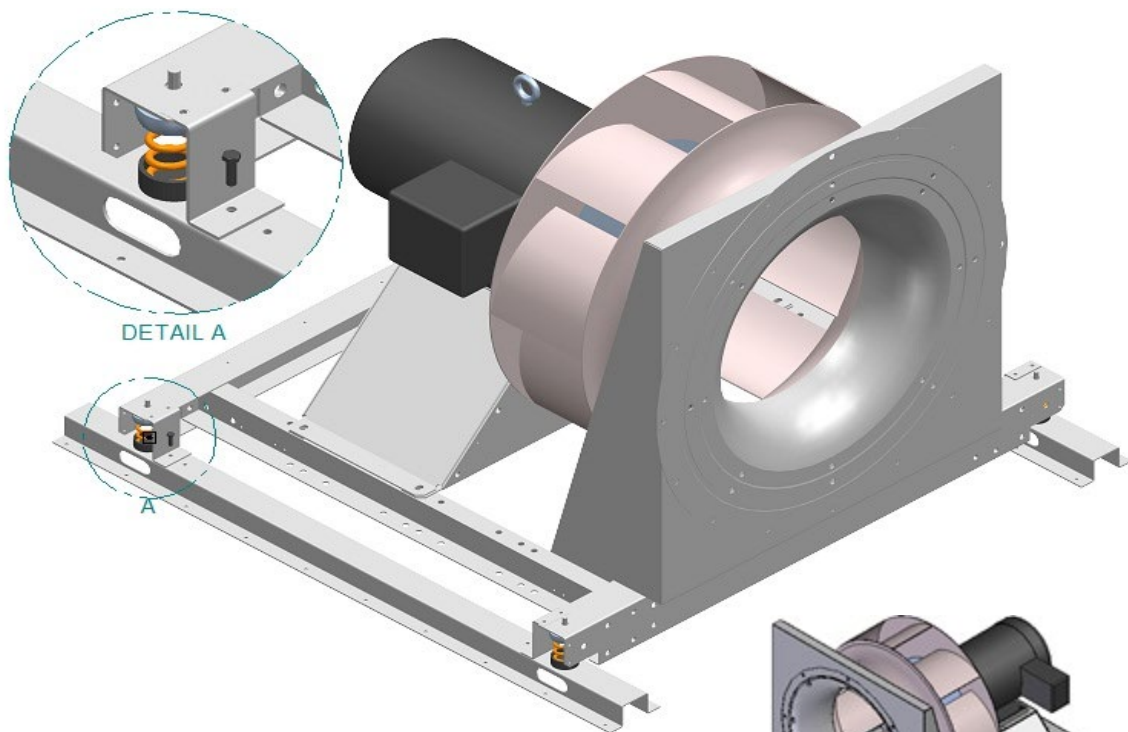

- If the blower frame includes two blowers (stack), in addition to base bolts removal (described above) remove ONE bolt from each bracket at the wall springs (B).

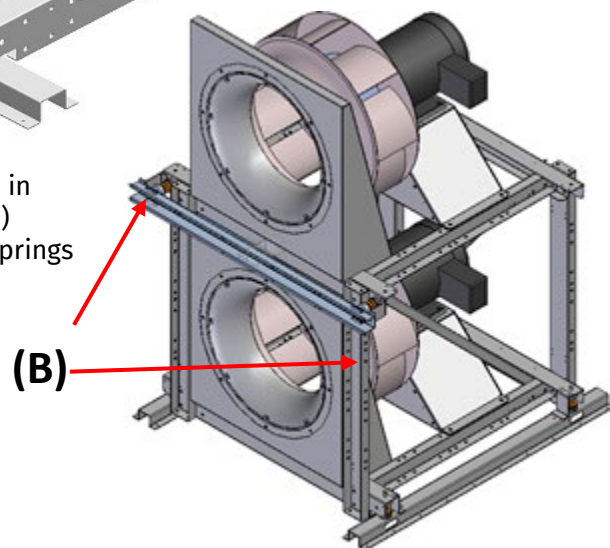

Pic. E.8

## “Split-Deck” dehumidifier (“Double-Decker”) – mechanical field disassembly and assembly

If requested, “Double-decker” (stacked) dehumidifiers are provided with means for site disassembly (splitting top deck from the bottom for shipping/delivery purposes) and assembly afterwards. Refer to **Disassembly and assembly Instructions**, provided with the dehumidifier!

### ⚠ CAUTION!

Before removing top deck from the bottom, ensure that ALL other system connections (piping, wiring, etc.) are disassembled.

Normally, there are two ways the top deck is attached to the bottom (refer to the one pertaining to your dehumidifier):

- **NE204 – NE232 indoor models:** decks attached with six to eight screws through the top deck floor & bottom deck roof (see Pic. E.9a):
  - locate the plastic covers/plugs at the front (a) and back (b) of the dehumidifier
  - remove all the screws and lift the top deck.
  - Once decks reassembled, reinstall removed screws and reinstall plastic covers.

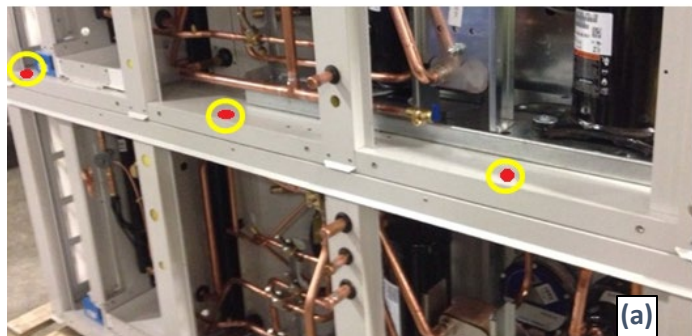

Pic. E.9a

- **NE216 – NE232 indoor/outdoor models:** decks attached with side joining and lifting strips (see Pic. E.9b):

- Locate and remove all screws on joining strips between the top and bottom decks - on the front (a) and back (b) joining strips and on the lifting bracket strips (c) on the sides of the dehumidifier.
- Once the dehumidifier is installed and decks are reassembled, make sure to reinstall the removed screws again.

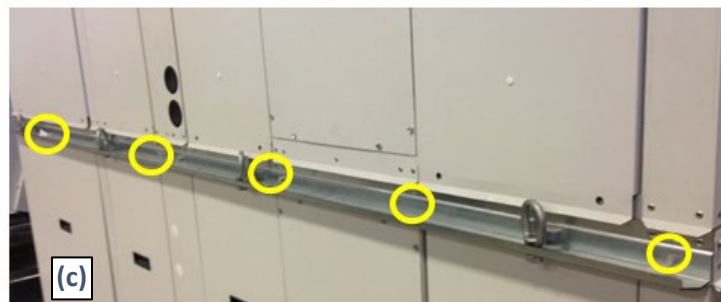
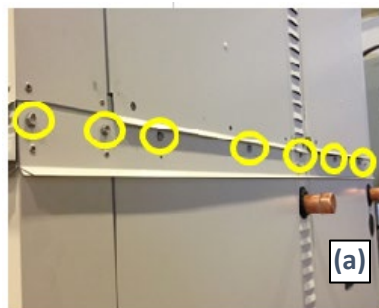



- Remove as needed the lifting eye-hooks to allow for doors removal.

Pic. E.9b

Make sure to also reassemble the other system connections (piping, wiring, etc.). Refer to respective chapters.

### “Split-Cut” dehumidifier – mechanical field assembly

Under special conditions, the dehumidifier may be split into two or more sections to ease the installation and delivery process. Refer to the dehumidifier submittal drawings and **Disassembly and Assembly Instructions**, provided with the dehumidifier (instructions include mechanical, piping, and electrical guidance for reassembly).

**⚠ WARNING!** DO NOT lift assembled dehumidifier. Lift each section separately and assemble once all sections are placed where intended.

- Place and align dehumidifier sections properly:
  - To aid with proper placement, sections normally are labeled with sequential numbers (“1”, “2” etc.) – ensure that each pair of adjacent sections at the split have same number (see Pic. E.10a).
  - Before final assembly of sections – ensure piping proper alignment; plan for pipe joining.
- Join sections with provided fasteners.

- Base angles (outside – see Pic. E.10. b) are normally bolted together with 3/8” bolts and internal angle (inside – see Pic. E.10 c) are normally attached with 5/16” bolts.

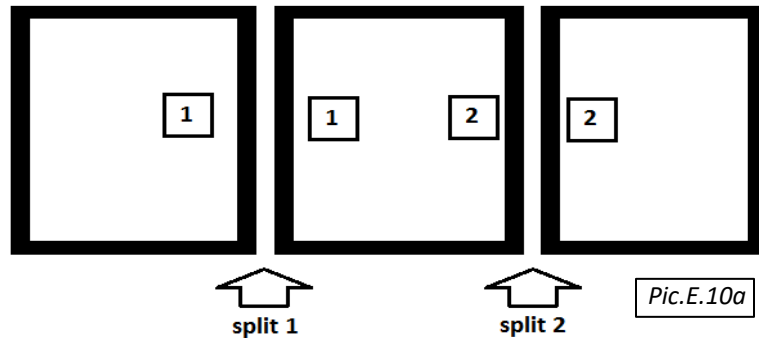

- Internal angles shape may vary depending on dehumidifier cabinet type.

- Ensure that all provided holes are used.
- Install provided roof rib cap (see Pic. E.10 d) over each jointed roof rib and attach it with screws; caulk the inner corner of roof rib cap prior.
- Caulk all the joints (roof, floor, walls) after reassembly.

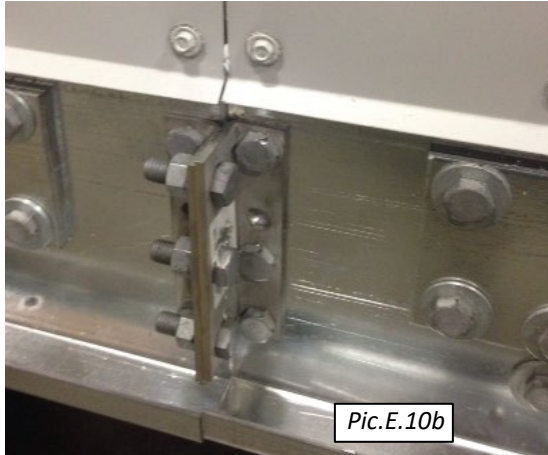

## Ductwork Connection

**⚠ WARNING!** All work must be done by qualified personnel in accordance with local and national Codes, Standards and Regulations as well as respective submittal documentation and manufacturer recommendations.

**⚠ CAUTION!** Obtain all necessary documentation (manufacturer documentation, submittal documentation, drawings etc.) and familiarise yourself with it before performing installation or any other related tasks.  
Refer to dehumidifier submittal drawings for location and size of dehumidifier duct connections.

## Ductwork Layout Considerations

Though ductwork layout is outside of scope of dehumidifier installation and duct connection to it, it is crucial to have proper ductwork layout for proper air distribution throughout the premise and proper dehumidifier operation. Proper ductwork layout encompasses, among others, following:

- ✓ Supply air must be directed/properly distributed to:
  - exterior windows and doors, skylights, etc.
  - breathing zone at the deck level and water surface.
  - remainder of the room to ensure there are no stagnant areas.
- ✓ Return duct grille must be located where it will optimize the entire airflow pattern (central/equidistant location of return grille, multiple return grilles if needed, etc.).
- ✓ Air short-circuiting must be prevented – no supply air diffusers near the return.

- ✓ Ensure grilles, diffusers and registers are delivering proper throw distance and CFM.
- ✓ Maintain the required minimum OA intake along with negative pressure in the space (respective Exhaust Fan and OA intake arrangement)
- ✓ Where/if applicable, establish direct exhaust of humid/chemical laden air from the source (locate exhaust grille above/close to spa, whirlpool, etc.).
- ✓ Duct sock installation: sock must be levelled (hangers are at the same heights), stretched and not sagging.

## Duct Connection – General Considerations

- ✓ All duct connections should be done in accordance with local and national standards.
  - Proper duct turns and transitions (sizing, distance, angles, turn vanes, etc.) should be used to minimize air friction losses and turbulence and to ensure the highest fan efficiency.
    - If space heater (electric heater, hot water coil or gas duct heater) is installed at the dehumidifier supply air termination, heater becomes a point for the supply duct connection – ensure proper duct transition, support, etc. is in place – refer to heater manufacturer guidance as needed.
  - Flexible connectors (canvas collars, etc.) should be used to prevent (reduce) vibration and sound propagation.
- ✓ Ductwork should not interfere with other devices/systems operation and accessibility:
  - fasteners (screws, etc.) attaching ducts to the damper, are not interfering with damper linkage, actuator(s) wiring and mounting brackets etc.
  - fasteners (screws etc.) are not interfering/penetrating any internal wiring, piping etc. possibly located behind the surface(s) ductwork is attached to – verify visually before installation and after.
  - damper actuator(s), filter racks, etc. are accessible/not blocked by the installed ductwork.

## Duct Connection – Special Cases

### Supply Air ductwork connection – SA Temperature Sensor installation.

Some dehumidifiers may require SA (supply air) temperature sensor to be installed in the duct after duct is connected.

In this case dehumidifier SA temperature sensor, tagged “**SUPPLY AIR TEMP SENSOR TO BE INSTALLED IN DUCT**” (see Pic. F.1), would be attached to the side or roof of the dehumidifier - such sensor is pre-wired to the dehumidifier control board at the factory and needs to be installed in supply ductwork.

- Install sensor at least 2'- 4' downstream of the dehumidifier or externally mounted space heater (if one is controlled by the dehumidifier) in the middle of the width of the duct.



Pic.F.1

## Field-installed duct-mounted space heater.

If space heater (gas duct heater, hot water or steam coil, electric heater, etc.) is not packaged with the dehumidifier and to be installed in the duct on site:

- ✓ follow said space heater manufacturer installation instructions (duct transitions, distances, clearances, support, direction, etc.), respective local codes and regulations and standard field practices.
- ✓ Install space heater in the supply duct, downstream of the dehumidifier.
- ✓ It is recommended for the space heater to be controlled by the dehumidifier control system (for efficient operation and air temperature maintenance).
- ✓ **Gas-fired duct heater.** Indoor-installed gas heater requires respective venting to be installed. Follow the heater manufacturer recommendation and respective local codes to select and install the venting system

**⚠ WARNING!** All work must be done by qualified personnel in accordance with local and national Codes, Standards and Regulations as well as respective submittal documentation and manufacturer recommendations.

**⚠ CAUTION!** When connecting the equipment to external mechanical and electrical systems, refer to submittal documentation and equipment labels and stickers for piping connection details.

## Piping Connection

### Piping Connection General Considerations

- Refer to the equipment main label and stickers at lines/piping termination to verify respective **connecting lines' sizes, flow directions** (IN/OUT) and **system type** (pool heating, space heating, etc.).
  - Flow direction stickers at respective piping stubs refer to the equipment it's attached to: IN – media (water, refrigerant, etc.) entering the equipment, OUT – leaving the equipment.
  - Select the line/piping size based on the equipment documentation (labels, drawings, etc.): diameters of the dehumidifier or OACC/OAFC piping stubs may be different from the required line size.
- Use proper **materials** and **pipe joining methods**, respective to given system (system media, pressure, etc.).
- Use proper **installation field practices** and **Code(s) requirements** (proper piping support, no pipe-to-edge contact, grounding/bonding, insulation, pressure testing, charging/filling, etc.)
- As/where needed, ensure that proper **isolation** and **balancing** means (valves, circuit setters, etc.) are in place.
- For water or water/glycol systems (pool water, space heating or cooling water, etc.) - provide proper means for **priming** (filling), **draining** and **aerating** (bleeding the air from the system): install automatic air bleeding valve(s) at each local top point of the system and drain/priming valves at the lowest point(s) of the system.

## Condensate Drain Connection and P-trap Installation

Each dehumidifier drain pan condensate line must be directed to an external drain and equipped with a P-trap to ensure proper drainage.

- If gravity disposal of condensate is not possible, use a condensate pump.
- If the drain line passes through an unconditioned/not-heated space, heat tracing is required to prevent the condensate in the drain from freezing.

Dehumidifier condensate termination(s) (or its location) is normally marked with respective label, stating whether given line is already equipped with a P-trap from the factory or not. If not, install a P-trap

### P-trap installation:

- Make sure that each drain connection has a P-trap
- Make sure that there is only one P-trap installed (do not double-trap).
  - If soft piping material is used (braided hose, etc.) - ensure the drain line is not sagging (this may create “double-trapping effect” and prevent condensate from proper drainage).
- Pitch the condensate drain line minimum of 1/8” per linear foot and support the pipe with code-approved hangers at least every 5 feet (see Pic. G.1).

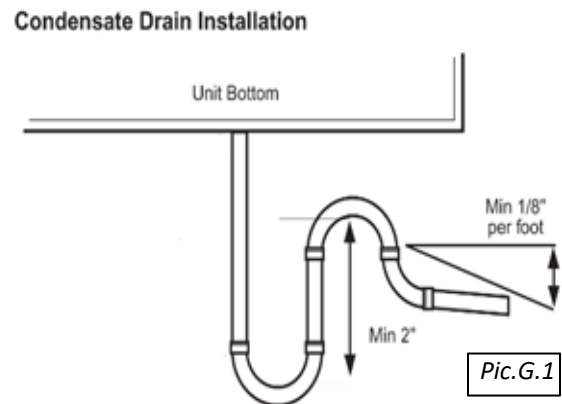

## Pool Water Heating Piping

If the dehumidifier is equipped with a pool water heater (to utilize compressor-generated heat for pool water heating), it would require pool water piping connected to respective dehumidifier pipe terminations.

Pic. G.2 shows an example of a generic pool water piping schematic.

**NOTE:** this schematic is an *example only* - design, provision and installation of actual pool water piping is not manufacturer responsibility and is to be done by a third party.

1	OACC/OAFC connections
2	Dehumidifier
3	P-Trap/condensate line
4	Check Valve
5	Ball valve(s)
6	Flow Meter
7	Auxiliary Pool Heater
8	Aux. Pump (lowest point)
9	Automatic Chemical Feeder
10	Pool Filter
11	Main Pool Pump
12	Pool Water Inlet (IN)
13	Pool Water Outlet (OUT)
14	Air Vent

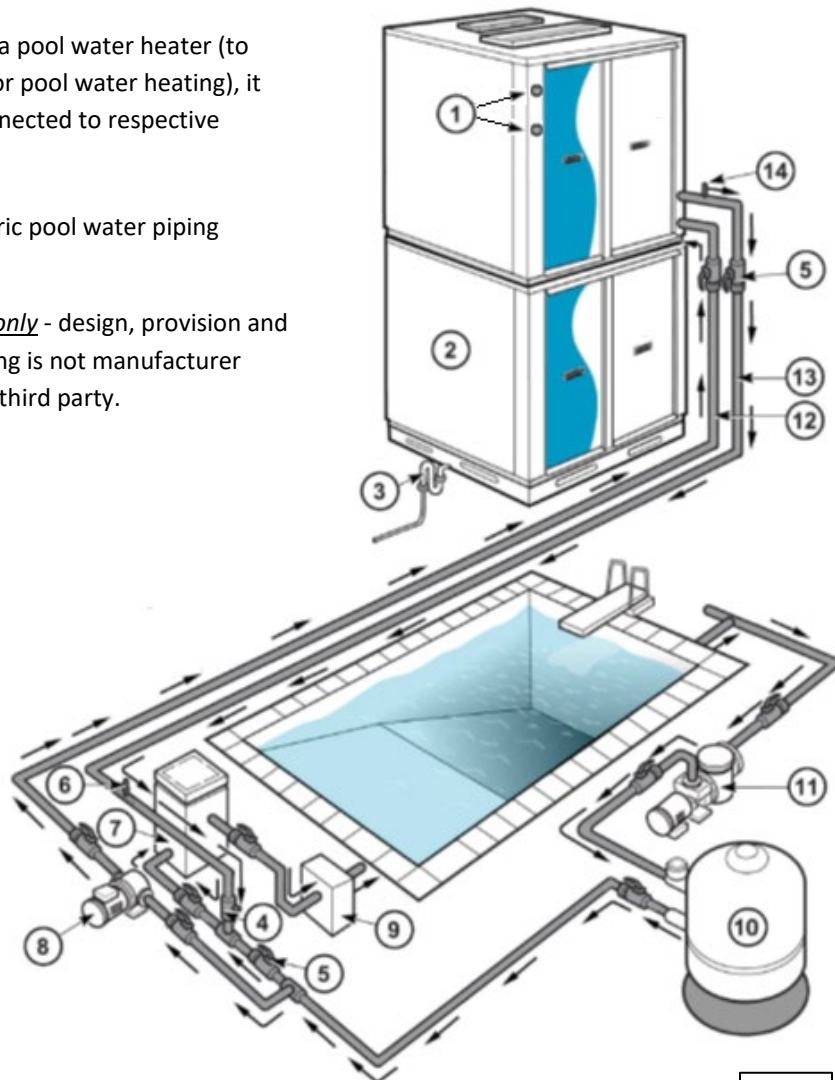

Pic.G.2

## Pool Water Piping

### Connections – General Considerations

- As shown on Pic. G.2, the chemical feeder must be located **downstream of (after)** the dehumidifier to prevent the pool water heat exchanger from being exposed to high chemical concentration.
- Auxilliary pump or main pool pump must be located **upstream of (before)** the dehumidifier.
  - The dehumidifier normally requires constant waterflow through (to ensure proper automatic control over pool heating feature); however, if requested, it could be equipped with means to control auxiliary pump. This set up would also require a pool water temperature sensor to be installed in the external pool water manifold/piping. Contact the factory if needed.
- Proper waterflow direction (refer to the dehumidifier piping termination stickers – Pool IN/Pool OUT), rate, GPM, and line set size (refer to dehumidifier Main Lable) must be maintained for proper and troublefree operation.
  - It is recommended to have means to adjust/balance waterflow (circuit setters, etc.)
  - Some dehumidifiers can be equipped with “full flow” heat exchangers (allowing for full volume of pool water flow) – refer to the main label info (pool water GPM).

## Outdoor Air Condenser Piping (NC models)

Current sub-chapter applies to outdoor condensers NC models, serving NE series dehumidifiers.

### Line Set Selection and Sizing

- Refer to dehumidifier and/or condenser main labels for line set sizing (both, **max line set length** and pipes' **diameters**):
  - note that line set **pipe diameters** may differ from respective piping connections size at the dehumidifier and condenser – refer to the equipment's main label.
  - one-way line set length (liquid OR hot gas line length) **must not exceed max line set length**, indicated on the main label (typically – 50').

**Note:** Do **NOT** exceed **max line set length** stated on the equipment's main label. Excessive line set length could result in equipment malfunction and premature failure. Do **NOT** increase lines diameters (oversizing line set) to compensate for excessive line set length – consult the factory first.

- The outdoor air condenser, in general, can be located above, below or at the same level as the dehumidifier, however some limitation may apply:
  - **Consult the factory if the condenser is to be located 20' or more below the dehumidifier.**
- Standard recommended pipe and fitting materials are refrigeration grade copper piping/tubing – refer to material applicability according to given application (refrigerant type, max working pressure, etc.).

### Piping

- ✓ Ensure proper piping support and bracing is in place – condenser and dehumidifier pipe terminations do not provide structural support for pipe line set.
- ✓ Proper piping practices (cleaning, sanding, reaming, wet-ragging during brazing, etc.), tools (pipe cutters, torches, etc.) and bonding methods, respective to pipe and fittings material must be followed/used.
  - Refrigeration piping/tubing must be brazed using respective brazing equipment and materials (flux, Sil-Fos® 5 brazing rod/wire or better etc.)
  - Where applicable, only refrigerant-approved lubricant/sealant in threaded connections should be used.
  - Purge the air from the line set and condenser with nitrogen prior to brazing to avoid soot built-up inside the lines – soot/debris may potentially plug refrigeration circuit devices and cause failure.
- ✓ Identify correct system pipe terminations on condenser and dehumidifier (typically labeled as “HG/hot gas” and “LQ/liquid”). Connect similarly labeled terminations (HG to HG, LQ to LQ).
- ✓ If the condenser is installed **above** the dehumidifier, install an **oil trap** at the start of and at every **15'** of vertical lift in the hot gas line as shown on Pic. G.4.
- ✓ Pitch the **horizontal** lines a min 1/2” every 5' in the direction of flow.
- ✓ Keep the hot gas and liquid lines a min of 2” apart to prevent heat transfer. Insulate the hot gas line where a person may come in contact with the line and be in danger of burning themselves.
- ✓ **CAUTION!** The dehumidifier typically is shipped pre-charged with refrigerant. Before cutting dehumidifier' pipe stubs off to connect line set - ensure that dehumidifier isolating hot gas and liquid ball valves are closed.

- Isolating ball valves typically have access ports that could be used for nitrogen purging, pressure testing, evacuating and charging. Check access ports for any pressure in the pipe stubs before cutting.
- Add access port(s) to the line set or at the condenser, if needed.

**NOTE:** The piping schematics shown on Pic. G.4, are example only - the design, provision, and installation of actual condenser line set is not manufacturer responsibility and is to be done by a third party.

### **Pressure Testing, Evacuating and Charging**

- Use proper field practices when pressure testing, evacuating, and charging the system.
- Pressure-test line set and condenser – refer to the dehumidifier main label for operating pressure level.
  - Use only dry nitrogen for pressure testing!
  - Condenser is typically shipped with some nitrogen holding charge (approx. 5-15 psi). Absence of holding charge does not necessarily indicate a leak/shipping damage, however it's recommended to leak test condenser prior/separately.
  - Ensure that dehumidifier isolating ball valves stay close during pressure test and evacuation.
- Evacuate line set and condenser – ensure that vacuum of **250 microns** (min) is achieved and held for **30 min.**
- Charge the condenser and line set with proper amount of proper refrigerant.
  - Refer to dehumidifier main label for **refrigerant type** and **field charge**. Ensure proper amount is added.
  - Use ball valve access port(s) or additionally installed access port(s) on the line set for charging.
  - Charge with liquid refrigerant **ONLY!** Once proper refrigerant amount (“field charge”) is added to the line set and condenser – open dehumidifier isolating ball valves to allow for refrigerant flow.



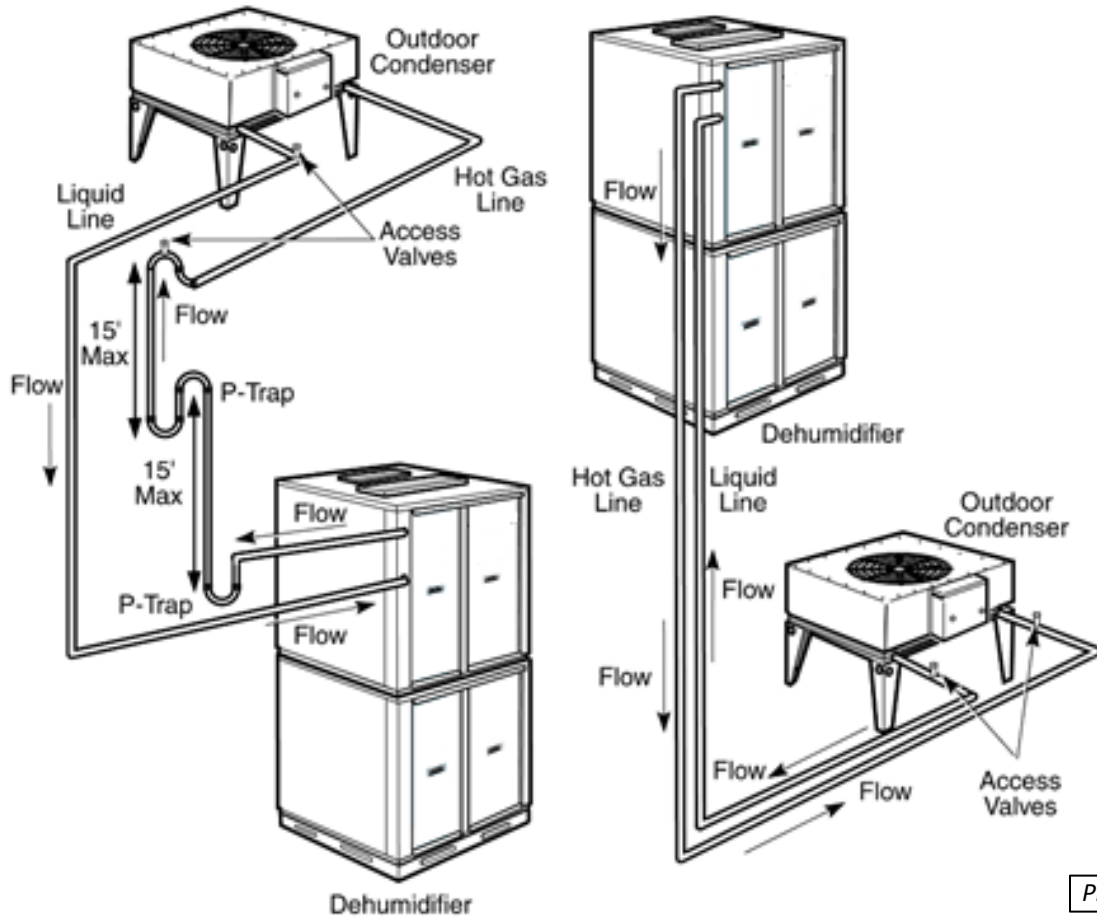

Pic.G.4

## Fluid Cooler Piping (NG models)

### Line Set Selection and Sizing

- Refer to dehumidifier and/or fluid cooler main labels for line set **typical diameter** (both lines, supply and return, are normally of the same size); note that size may differ from respective piping connections size at the dehumidifier and fluid cooler.
  - **Typical** line set **diameter** accounts for system proper operation if line set **total equivalent length** does not exceed (approx.):
    - 200' – for NG-V-02 fluid cooler model\*
    - 300' – for NG-V-12 fluid cooler model
    - 450' – for other fluid cooler models
  - If the total equivalent length exceeds above value, the line set diameter must be upsized to next size (e.g., step up diameter from 1 ¼" to 1 ½"). Contact the factory for more details, if needed\*\*.
- \* in some cases, NG-V-02 fluid cooler model may accommodate higher **total equivalent length** with **typical diameter** – contact the factory for details.
- \*\* typically, the fluid cooler is provided with pump package or serves the dehumidifier, equipped with its own pump, therefore no additional pump is needed. However, in some cases (fluid cooler and dehumidifier are not packaged with pump or in case of extremely high total equivalent length, etc.) additional' pump may be required. Contact the factory if needed.
- Standard recommended pipe and fitting materials are PVC, steel and copper. Other materials may also be suitable – refer to material applicability according to given application (system media, max working pressure, temperature, etc.). For outdoor piping, use only

### Piping

- ✓ Ensure proper piping support and bracing is in place at piping manufacturer recommended intervals AND terminations – fluid cooler and dehumidifier pipe terminations do not provide structural support for piping.
- ✓ Use outdoor-rated UV-stabilized PVC, or other material.
- ✓ Proper piping practices (cleaning, sanding, reaming, wet-ragging during soldering, etc.) and bonding methods, respective to pipe and fittings material (soft soldering, gluing, etc.) must be followed.
- ✓ Fluid cooler and dehumidifier pipe terminations stickers (IN/OUT) refer to respective equipment:
  - Identify correct system pipe terminations (typically labeled as “AC fluid” or “Cooling”)
  - Connect fluid **cooler OUT to dehumidifier IN**; connect **fluid cooler IN to dehumidifier OUT**.
- ✓ Install valves/devices to isolate, drain, charge and remove the air from the fluid cooler and line set.
  - Fluid cooler typically is not provided with isolating valves – install as needed.
  - Install drain/charge valve(s) at the lowest point(s) of the line set; install air bleeding valve(s) at the top point(s) of the line set (see Pic. G.3, (A) and (B)).
  - Fluid cooler and dehumidifier would typically have drain/charge valves installed at their lowest point(s).
  - Pump package (if fluid cooler is equipped or provided separately with one) typically includes pump with pressure gauges and expansion tank; same applies to NP series dehumidifiers (pump with pressure gauges and expansion tank would normally be part of the dehumidifier).

Pic. G.3 (A) shows typical piping schematic for single fluid cooler serving single cooling circuit. Piping schematic for single fluid cooler serving multiple cooling circuits (200 series NE dehumidifiers etc.) is shown on Pic. G.3 (B).

- **NOTE:** the given schematics are example only - the design, provision and installation of actual fluid cooler piping is not manufacturer responsibility and is to be done by a third party.

### Pressure Testing and Charging

- Refer to the fluid cooler and/or dehumidifier's main label and submittal documentation for **operating pressure** and **cooling media** selection.
  - Typically, mixture of food grade **propylene glycol** (with rust inhibitors added) and **distilled water** is used as a cooling fluid. The mixing ratio is typically **30-35% glycol**; however, a higher glycol concentration (e.g., 50%) could be used for northern application – refer to the equipment submittal documentation.
  - To calculate approximate (!) Total System Volume (amount of fluid required for system charging), add Internal Fluid Cooler Volume (see submittal documentation) to Line Set Volume (calculate based on the used pipe diameter and line set actual length). Increase calculated Total System Volume by 3-5% - final charge of the system would be determined during the charging (see below).
- Charge system at its lowest point and bleed the air out at the system top point(s); charging at multiple lowest points (at fluid cooler and dehumidifier) may be required.
  - Use a separate **charging pump**. The dehumidifier and/or fluid cooler pump(s) are selected/ designed to maintain fluid circulation and not be used for charging. Ensure fluid is clean, free of any debris etc.
  - Ensure thorough air removal from the system – airlocks will prevent system from operating properly.

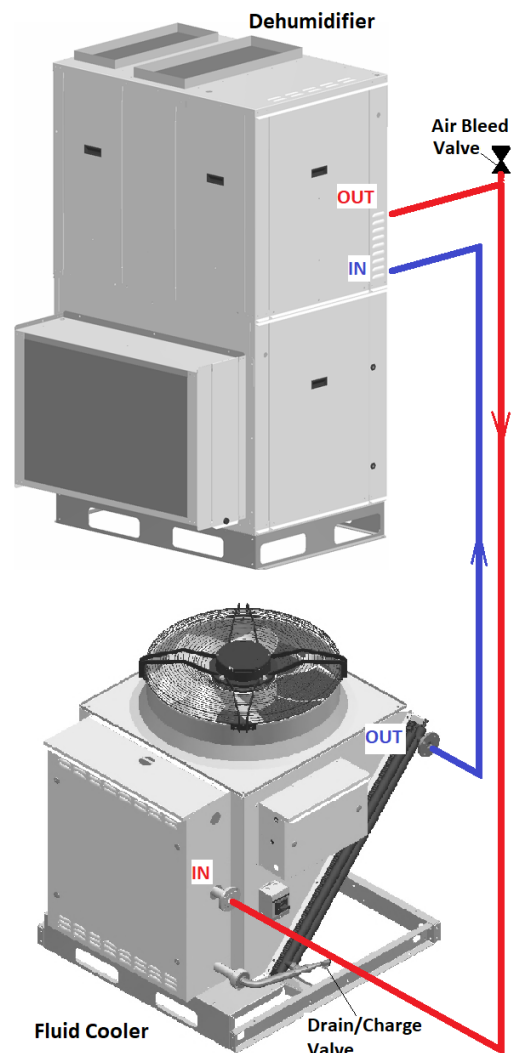

- Ensure that static pressure at the highest point of the system is at least 15-20 psi. Verify it after bleeding all the air from the system.

Pic. G.3 (A)

## Other Piping Systems and Special Cases

### Space Heating and Space Cooling Hydronic Systems

Requirements, outlined in **Piping Connection General Considerations** (see above), apply to all types of space heating and/or space cooling fluid systems (water, glycol, etc.) – refer to respective piping

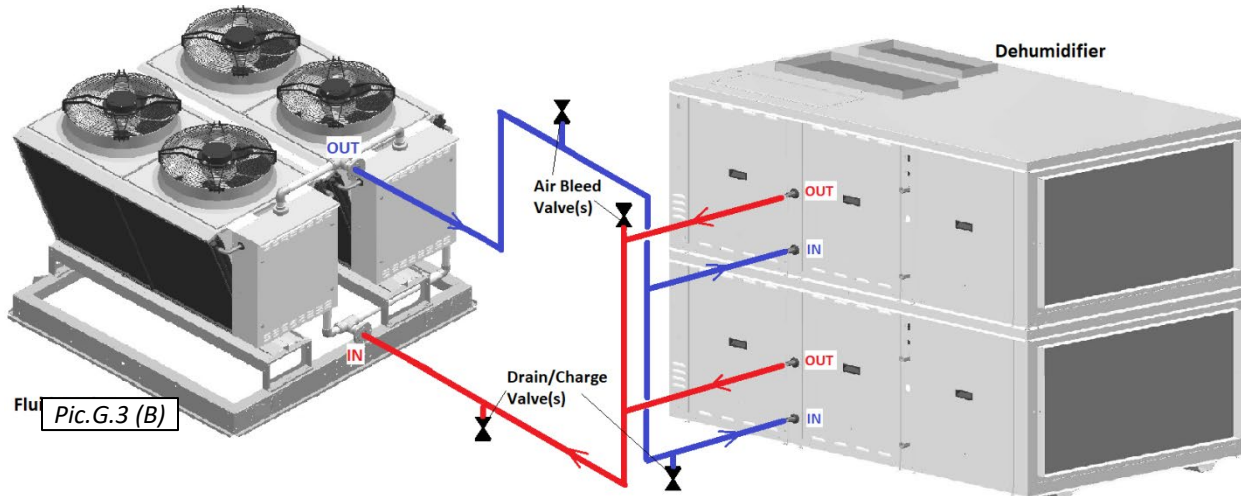

termination labels (IN/OUT), main label (for line sizing) etc.

- ✓ **ATTENTION!** If **steam space heating coil** is used – follow respective Code(s) recommendations, field practices and steam coil and associated equipment (valves etc.) manufacturer’s guidance.

### Gas-fired Space Heaters (duct gas heater, gas boiler, etc.)

- ✓ Follow respective gas heater manufacturer requirements, as well as respective local codes, when piping and connecting **gas line** to the heater (pipe sizing, supplied gas pressure, etc.). Refer to heater or dehumidifier labels and stickers to locate gas connection.
- ✓ Indoor-installed gas heater (boiler, duct heater, etc.) must be equipped with flue gas venting system – consult gas heater manufacturer for proper venting system selection.
  - Gas heater, packaged with the outdoor dehumidifier, normally would have provision for flue gas venting, however in some cases (strong wind influences, location specifics, etc.) additional venting system may be also required – consult gas heater manufacturer for proper type selection.

### “Split-Cut” dehumidifier - piping assembly

When dehumidifier is provided from the factory in sections, field-assembly is required, including dehumidifier internal piping reassembly.

Normally, such dehumidifiers are accompanied with **Disassembly and Assembly Instructions** – refer as needed.

✓ **Remove cups/plugs and join pipes respectively.**

- To facilitate reassembly and avoid ambiguity, closely located pipes are cut at the factory in “checkered” pattern (see Pic. G.5) – once dehumidifier sections are aligned properly, respective pipes would align too.
- Follow standard field practices, applicable to respective pipe material/type and joining methods; ensure that pipes and couplers are properly cleaned, sanded, reamed, etc. as applicable. Normally, respective couplers are provided with the dehumidifier.

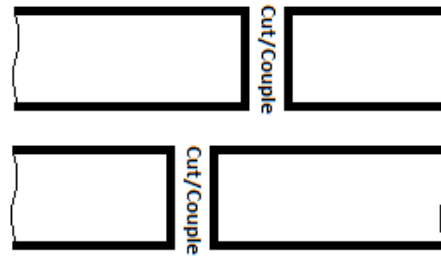

Pic.G.5

✓ **Pressure test/test for leaks re-joined piping and charge/upcharge re-joined circuit with respective fluid.**

- Refer to dehumidifier submittal documentation and main label for respective circuits operating pressure and media (water/glycol type and mixture ratio, type of refrigerant, etc.).
  - Follow proper field practices working with **refrigeration circuits** (brazing with nitrogen, vacuuming, etc.); refer to recommendations in **Outdoor Condenser Piping** (see above).
- Depending on various circumstances, split-cut dehumidifier could be shipped with piping circuits completely empty or partially charged – verify fluid presence in the circuit prior.
  - Normally, **water and/or glycol circuits** are provided empty – once joined, circuit must be charged fully. Refer to **Fluid Cooler Piping** recommendations for charging.
    - Fill/upcharge water/glycol at the bottom of the system, bleed the air from ALL top bleeding valves (manual and automatic). Ensure all air is bled out. Upcharge, if needed, to achieve min 20-30 psi static pressure at the bottom of circuit.
  - **Refrigeration circuits**, depending on dehumidifier type, size and number of splits/sections, could be provided completely empty or partially charged: be aware of refrigerant content in the circuits and the way circuits were split at the factory.
  - Typically, if the dehumidifier is partially charged (normally, NP series):
    - Compressor(s) and receiver(s) valves are **closed** and
    - Evaporator coil(s) as well as suction line (up to compressor valve) and pump down liquid line (up to receiver valve) are **empty**, rest of circuit(s) contain refrigerant. Filter-drier core normally is provided separately for installation before vacuuming of the circuit’s empty section.
  - Refrigeration circuit(s) final charge may need to be verified and adjusted (as needed) during dehumidifier start. For current upcharge adjustment, refer to refrigerant level in receiver sight glasses: top sight glass float should be at the bottom, bottom – at the top.

✓ **Finalize piping reassembly:**

- As needed - retighten pipe braces, reinstall piping insulation (refrigeration circuit suction line(s), chilled water coils line(s), etc.)

## Remote Gas Boiler Package Installation and Piping Connection

Normally, dehumidifiers provided with a gas boiler package are accompanied with the boiler manual and **Remote Boiler Package Installation and Start Up Instructions** – refer as needed.

### Venting and Gas connections.

- ✓ If package includes two boilers, connect gas and venting to each boiler separately.

### Water piping connections.

Boiler package piping recommendations are similar to ones, outlined in **Fluid Cooler Piping** (see above):

- ✓ Normally, pipe line size could be kept same as the boiler package pipe stubs; if line set **total equivalent length** exceeds **100'** - upsize to next pipe size.
- ✓ Boiler package pipe stubs are labeled respectively (**IN** and **OUT** – see Pic. G.5). Connect boiler package **OUT** to dehumidifier **IN**; connect boiler package **IN** to dehumidifier **OUT**.
  - **ATTENTION!** Separate boiler packages are tested at the factory, using “**test loop**” – short pipe connecting boiler package **IN** and **OUT** stubs. Such loop is normally removed at the factory; if this loop is still in place – remove it to connect pipe line set
- ✓ Once piped, pressure test and charge heating system (boiler package, line set and coil) – refer to the dehumidifier’s main label and submittal documentation for **operating pressure** and **heating media** selection:
  - Both, distilled water or water-glycol mixture (approx. ratio is 30-35% of food grade propylene glycol) are suitable for boiler package – refer to given dehumidifier submittal documentation.
  - Recommended static pressure is approx. 40-50 psi

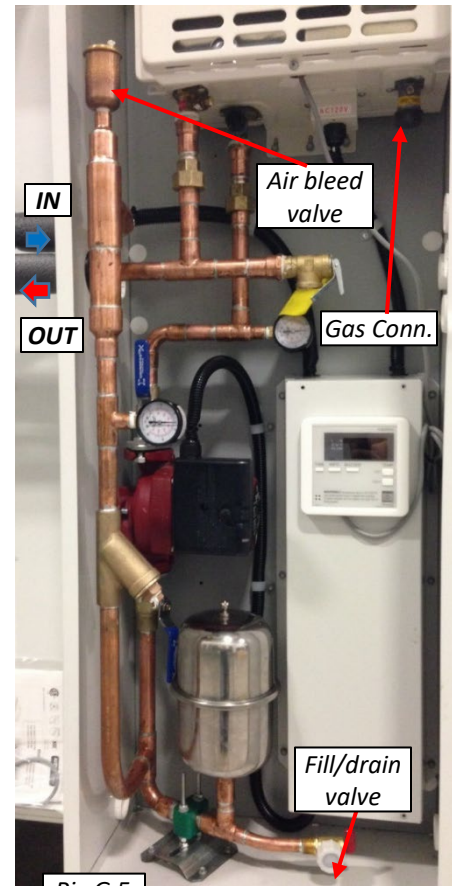

Pic.G.5 package, line set and

## Electric Connection: power, control and communication

**⚠️ WARNING!** All work must be done by qualified/licenced personnel in accordance with local and national Codes, Standards and Regulations as well as proper field practices, respective submittal documentation and manufacturer recommendations.

**⚠️ CAUTION!** When connecting the equipment to external mechanical and electrical systems, refer to submittal documentation and equipment labels and stickers for piping connection details.

**⚠️ CAUTION!** Use **copper** conductors only. Equipment electrical and control terminals are not designed to accept other types of conductors. Use of aluminium or other wiring may result in galvanic corrosion and/or overheating that may cause equipment malfunction and/or failure and would void the warranty.

### Electrical Connection - General Considerations

- Select power supply wire gauge and, as/when needed, external power apparatuses (disconnects, breakers, etc.) according to equipment electric data (MCA, MOP, etc.), provided on the main label, as well as respective local and national codes and regulations.
- Equipment (dehumidifier, OACC, OAFc etc.) are accompanied with their respective wiring diagrams, depicting equipment internal wiring and terminals for external connection (power supply, control terminals, etc.) – refer as needed.
- Properly seal all penetrations made/used in the equipment cabinet outer walls. Failure to do so may result in water/humid air infiltration that could lead to equipment malfunction or damage.
- Ensure that all metal shards and filings are swept to avoid possible corrosion or damage to electrical components. Ensure that wires are properly protected/isolated from the equipment cabinet sharp edges, hot surfaces, etc.

### Equipment Main Power Connection

Main (“high”) power is to be brought to equipment main PDB (power distribution block, see Pic. H.1 (b)), located in the main electric panel – refer to equipment labels and manual for panel and PDB location reference. If equipment has a **disconnect**, power must be brought there (Pic. H.1(a)) – disconnect would be factory-wired to the PDB or devices directly. Normally, OACC and OAFc are equipped with disconnects, as well as most NP series dehumidifiers.

- Verify that proper voltage and number of wires (single -phase Vs three-phase – see Pic.) are connected to the equipment – refer

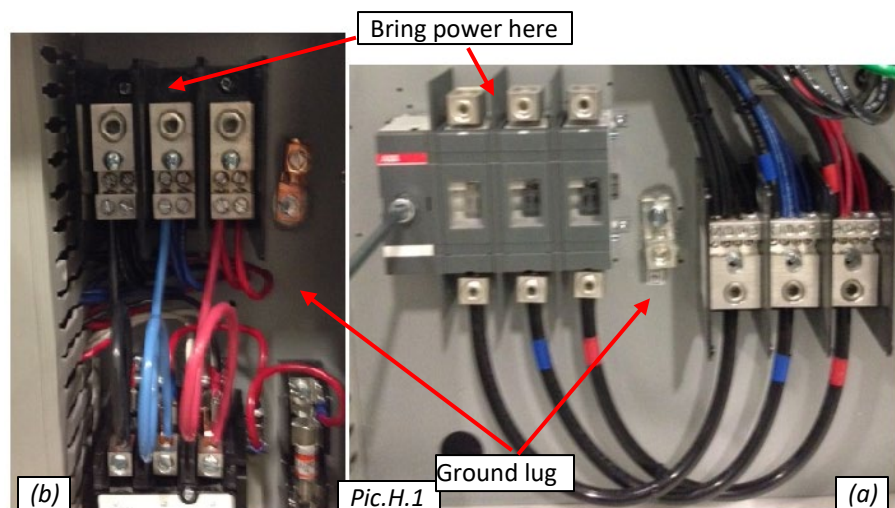

to the main label and submittal documentation.

- Dehumidifier with **electric heaters** and **single-point power connections** must have **one** power wires set brought to **PDB** (normally labeled “L1-L2-L3), located **in electric heater** (see Pic. H.2).
- Dehumidifier with **electric heaters** and **dual-point power connections** must be powered separately from electric heater - one set of power wires brought directly to the dehumidifier PDB (located in its main electric panel), another set – directly to electric heater.

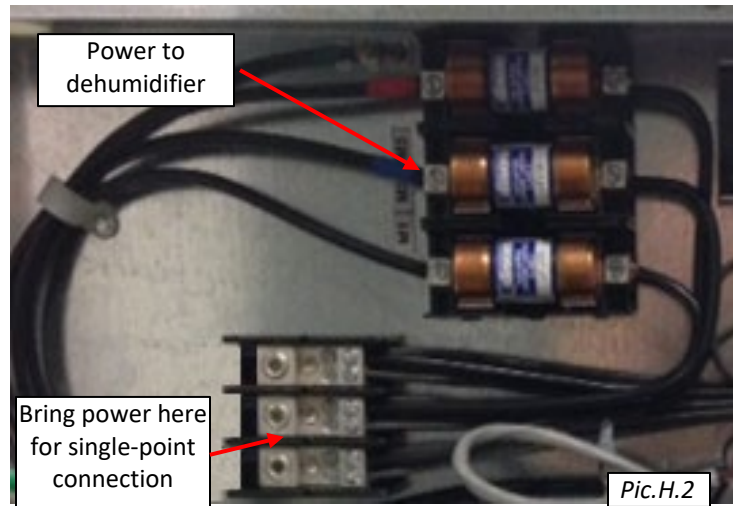

Pic.H.2

## Outdoor Air Condenser and Fluid Cooler Power and Control Connection

Both, dehumidifier and OACC/OAFC are provided from the factory with their respective wiring diagrams, depicting equipment internal wiring and connection points (pins, terminals, etc.) for external (“field”) wiring – refer to the said wiring diagrams, as well as Field Wiring Diagram (part of submittal documentation) as needed.

Power connection to OACC and OAFC must follow same recommendations outlined above; in most cases, condensers and coolers are equipped with a disconnect – connect power there.

To control OACC/OAFC operation, install control wires between OACC/OAFC and the dehumidifier.

- Use copper gauge 18 multi-strand conductors.
- Refer to specific dehumidifier info for number of conductors. Normally four conductors are sufficient, however it is recommended to run one or two spare ones.
- Ensure proper wire insulation/protection selection (exposure to cold weather, UV light, etc.)

## Field Wiring – External Control and Communication

Although normally dehumidifier is provided with all sensors and control devices, required for its operation, installed and pre-wired from factory, various external devices and systems could be also connected to the dehumidifier control system.

- in some cases, outlined above (see Duct Connection and Outdoor/Indoor Air Filter Rack Installation), some air sensors (supply air, outdoor air, etc.), though pre-wired, may need to be field-installed.

Dehumidifier control system is capable to control remote ventilation and conditioning devices (space heaters, exhaust fans, OACC/OAFC, etc.) as well as receive/integrate external commands – refer to submittal documentation, contact factory as needed before connecting to and/or powering any devices from dehumidifier control board.



Normally, if requested, external sensors/devices connections would be shown on the equipment wiring diagrams. For case-specific control connections – contact factory.

**⚠ CAUTION!** Dehumidifier control board is designed to operate with 24VAC and 24VDC circuitry only! Connecting higher voltage circuitry to the dehumidifier control board can cause failure or malfunction of the board and/or other connected devices!

Some of the most common systems/devices, connected to dehumidifier, are various BMS (Building Management System), local safety systems (fire and smoke detection) and dehumidifier remote operator panel (ROP). Pic. H.3 below shows dehumidifier control board terminals used for said control wiring.

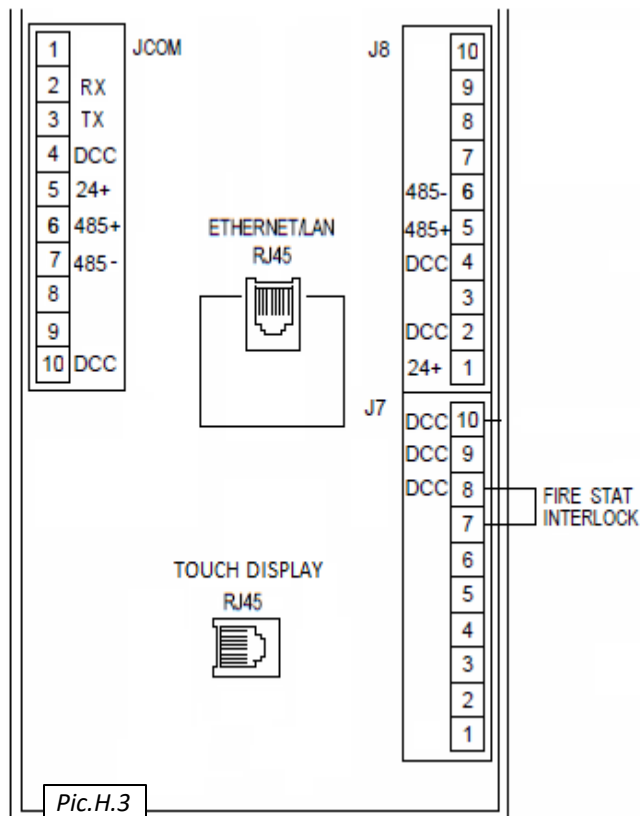

Pic.H.3 serial port; panel is equipped with RJ-45 socket.

Touch Display OP is normally installed inside the dehumidifier (referred to as local operator panel), and normally connected with factory-provided “patch” (straight-through) cable, plugged into dedicated control board RJ-45 socket (see Pic. H.3); this RJ-45 socket is internally connected to same serial port as pins 6 (485+) and 7 (485-) on the board terminal **JCOM**.

- **NOTE:** It is not recommended to have multiple devices (Ops, etc.) connected to the same serial port; do not connect any other device (ROP etc.) to pins 6 and 7 on terminal **JCOM**, if local OP is plugged into RJ-45.

Same or similar (additional) panel could be installed remotely, as far as 1000’ away from the dehumidifier (remote operator panel – ROP). ROP Touch Display is normally connected to pins on the terminal **J8**:

- For other control connections refer to dehumidifier submittal documentation and wiring diagrams; contact the factory as needed.

### Fire/Smoke detecting system interlock.

Dehumidifier control system can be interlocked with external fire/smoke alarm system (to stop dehumidifier operation if fire or smoke is detected). Control board accepts dry-contact signal (closed contact is accepted as NO FAULT; open contact is accepted as FAULT/ALARM).

- To do so, remove the factory installed jumper from pins 8 and 7 on board terminal J7 (see Pic. H.3) and connect dry-contact signal wires there.

### Operator Panel local and remote installation.

Touch Display operator panel (OP) is provided with the dehumidifier (to allow for operator – maintenance, service personnel etc. – communication to the equipment).

Touch Display OP communicates over RS-485

- Use a CAT5 or CAT6 cable. If the cable comes with RJ-45 jacks on both ends – cut one end off; if no jacks attached, attach it one side of the cable, using respective T568 wiring standard (A or B, see Pic. H.4).
- Connect cable to control board pins on terminal J8 – see table H.1 below (terminal JCOM pins layout is referenced also, in case of direct wiring (bypassing dedicated RJ-45 jack) is needed).
  - Multiple devices could be connected to same 24VDC power and common board pins, load permitting.

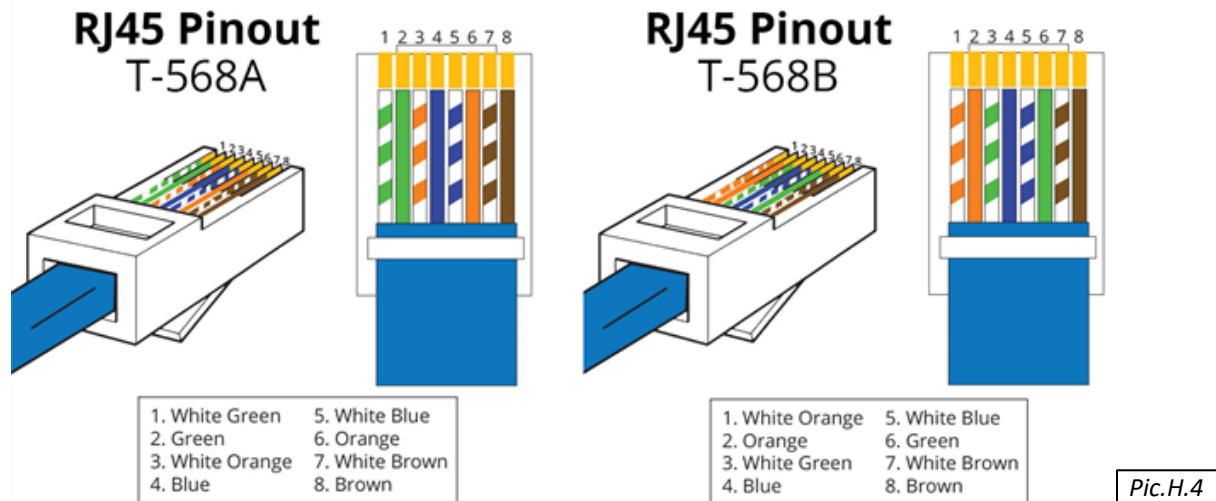

Table H.1

<b>Control Board terminals/pins (Pic. H.3)</b>		<b>RJ-45 Pinout (cable wires layout) (Pic. H.4)</b>		
<b>Function</b>	<b>J8</b>	<b>JCOM</b>	<b>T-568A</b>	<b>T-568B</b>
24VDC power (24+)	1	5	Blue & White-Blue	Blue & White-Blue
24VDC common (DCC)	2	4	Brown & White-Brown	Brown & White-Brown
Serial port RS485 (485+)	5	6	White-Green	White-Orange
Serial port RS485 (485-)	6	7	Green	Orange

Refer to **Touch Display Manual** for more details on its operation, connection, etc.; refer to dehumidifier wiring diagram and submittal documentation as well; contact the factory if needed.

### External BMS and WebSentry Communication

**WebSentry** is a web application used to communicate to the dehumidifier via the Internet; it requires a regular connection to a local network with standard Ethernet cable (CAT5 or CAT6 with RJ-45 jack).

- Connect the cable to ETHERNET/LAN RJ-45 jack (see Pic. H.3) on the sub-board (“core module”)
- Other end could be connected directly to a network switch, router or wireless Access Point (providing WiFi connection to the local network).

Certain configuration of dehumidifier control software and local network settings may be required – refer to **WebSentry Installation Guide** document and other related documents; contact the factory as needed.

### **BACnet**

Currently, three BACnet protocols are supported: BACnet Over Ethernet, BACnet IP, and BACnet MSTP.

**BACnet Over Ethernet** and **BACnet IP** communication is established in the same method as WebSentry (over Ethernet cable). Follow the same recommendations for connection as for WebSentry – see above.

- BACnet and WebSentry, communication can co-exist and not exclusive of each other.

BACnet MSTP communication is established over RS-485 serial port:

- Connect two wires to pins 5 and 6 on J8 terminal (see Pic. H.3):
  - use twisted-pair wires only;
  - If both, ROP and BACnet MSTP, connection is required – connect BACnet MSTP on terminal J8 as described above and relocate ROP connection – contact the factory for guidance.

Certain configuration of dehumidifier control software, BACnet-based BMS and local network settings may be required to establish proper communication, access desired parameters/points, etc.– refer to **BACnet Objects** and **BACnet PICS** documents and other related documents; contact the factory as needed.

### **Modbus**

Modbus communication is established same way as BACnet MSTP (over RS-485 serial port). Follow the same recommendation for connection as for BACnet MSTP – see above.

Certain configuration of dehumidifier control software, Modbus-based BMS and local network settings may be required to establish proper communication, access desired parameters/points etc.– refer to **Modbus Registers** document and other related documents; contact the factory as needed.

### **LON**

LON communication is established over RS-232 serial port (hosted on the control board terminal JCOM – see Pic. H.3), and requires LonWorks Gateway (installed at the factory, if initially requested, or field-installed).

Pic. H.5 and Table H.2 below show standard connections layout for dehumidifier control board terminal JCOM and LonWorks Gateway.

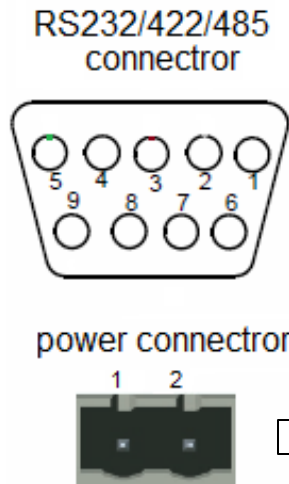

Pic.H.5

Table H.2		
Gateway pin	JCOM pin	Function
<i>Power connector</i>		
1	5	24VDC power (24+)
2	4	24VDC common (DCC)
<i>RS232/422/485 connector</i>		
2	3	Serial port 232 (RX)
3	2	Serial port 232 (TX)
5	10	24VDC common (DCC)

Certain configuration of dehumidifier control software, LON-based BMS and local network settings may be required to establish proper communication, access desired parameters/points, etc.– refer to **LON Objects** document and other related documents; contact the factory as needed.

- LonWorks Gateway must be pre-programmed and pre-configured (if field-installed) – refer to respective device manual for configuration and troubleshooting (indicators pattern, etc.)

## Field Wiring – Special Cases

**⚠ WARNING!** Some equipment, for various (installation, logistics, etc.) reasons may be provided partially disassembled (“split”) or would require site disassembly and reassembly afterwards. Do not power such equipment without verifying that all power and control connections are re-established correctly!

### “Split-Deck” dehumidifier (“Double-Decker”, 200-series) – electrical field disassembly and assembly.

#### Electrical Disassembly

Unless the following was done at the factory, disconnect and remove control and power wires in the bottom deck and pull them into the top deck:

- Ensure that factory-installed wire tags are in place before removing wires from their terminals (see Pic. H.6).
- Remove control cable (going to the top deck) connections from control terminal strip;
- Remove power wires (including ground) from the power distribution block and ground lug/strip.

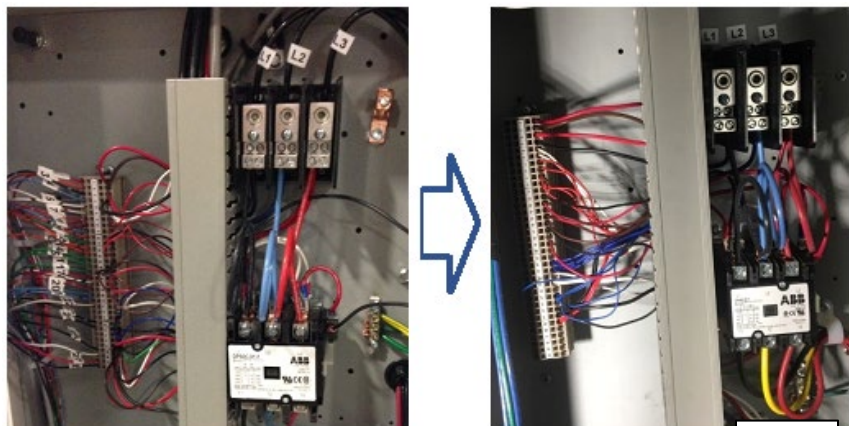

Pic.H.6

- Pull removed cables/wires from the bottom deck into the top one. Ensure that wire tags are stayed intact.

### **Electrical Reassembly**

Once the dehumidifier is installed and decks are reassembled, reinstall control and power wiring.

- Pull wires back into bottom deck and install into respective pins/terminals; refer to wires tags, dehumidifier wiring diagram and wiring diagram legend.

### **“Split-Cut” dehumidifier – electrical field assembly.**

Each “split-cut” dehumidifier is provided with field reassembly instructions with **Reassembly Additional Information** portion, that includes (when/if applicable):

- Disassembly methods brief description (if special methods/tools are needed);
- Reassembly Wiring Legend, that lists removed cables/wires (with their tags per wiring diagram, color-coding, etc.) and junction boxes and terminals they are removed from (with junction boxes designation/location, etc.)
  - Normally, wires are disconnected from junction boxes or internal panels, labeled, pulled out from one section and coiled up in other section to allow for mechanical separation of the sections.
- List of temporarily removed/disconnected devices (sensors, actuators, etc.), referencing their proper position/location.

Obtain said Reassembly Additional Information (if not provided with the equipment – contact the factory to request one) and reinstall wires, temporary removed devices, etc.

- Refer, as needed, to labels/stickers (indicating dehumidifier compartments, etc.), dehumidifier wiring diagram and submittal documentation. Contact the factory if needed.