



# DRY COOLERS

NG SERIES

## INSTALLATION MANUAL

[PoolPak.com](http://PoolPak.com)



## Table of Contents

<b>General Information</b> .....	<b>2</b>
Operating Safety (Warnings, Cautions, and Notes) .....	2
Reference and Additional Information .....	2
<b>Delivery and Storage</b> .....	<b>4</b>
Receiving Checklist .....	4
Shipping Damage Handling.....	4
Storage .....	5
<b>Mechanical Installation</b> .....	<b>5</b>
Lifting and Rigging .....	5
General Mechanical Installation Requirements .....	6
Mechanical Installation – Special Cases.....	7
<b>Piping Connection</b> .....	<b>9</b>
Piping General Considerations.....	9
<b>Electrical Connection: Power and Control</b> .....	<b>13</b>
Electrical Connection General Considerations.....	13

## General Information

This manual provides basic information about various installation aspects of the applicable equipment and its additional and auxiliary systems and devices.

Important information regarding operation and maintenance of said equipment is normally provided with the equipment and can also be obtained from the manufacturer (see **Contact Us** below).

## Operating Safety (Warnings, Cautions, and Notes)

### FOR YOUR SAFETY: READ BEFORE PERFORMING ANY INSTALLATION OR OTHER TASKS!



Only qualified technicians should install, operate, maintain or service mechanical equipment! Make sure to read this manual before performing any installation tasks to familiarize yourself with the equipment as well as with any potential hazards. Always exercise caution!

#### **Beware of chemicals!**

Equipment may contain water/glycol mixtures – refer to equipment data for more details.

The following warnings, cautions, and notes appear throughout this manual and referenced documentation whenever special care must be taken to avoid potential hazards that could result in equipment malfunction or damage, personal injury, or death.



#### **WARNING**

Indicates a potentially hazardous situation which could result in serious injury or death if handled improperly.



#### **CAUTION**

Indicates a potentially hazardous situation which could result in moderate injury or equipment damage if handled improperly.

#### **Note**

Indicates a situation that could result in equipment damage or improper/ineffective operation if handled improperly.

## Reference and Additional Information

For safe, efficient and problem-free operation, it is critical to handle the equipment and related systems and components properly at each step - from receiving and storage to installation and start up. Relevant information can be found in the respective documents (**Operation and Maintenance Manual** etc.) provided with the equipment.

 **WARNING!** Any work (installation, start up, service, maintenance, repair, etc.) on any mechanical equipment must be performed in accordance with respective manufacturer recommendations as well as submittal documentation, local Codes and Regulations, and appropriate field practices. Failure to do so could result in personal injury, equipment damage or malfunction, and will void equipment warranty. Only qualified and properly trained individuals should perform tasks on this equipment.

## Warranty

The manufacturer standard warranty statement can be found in the **Operation and Maintenance Manual**, provided with the equipment (also could be requested from the manufacturer).

### **Attention: Warranty Conditions and Coverage.**

**NOTE.** The equipment is provided with comprehensive conditional warranty coverage. Any warranty work sought to be reimbursed must be approved by the manufacturer **Customer Support Team** prior to work commencing. Installation, start up, maintenance etc. are not within warranty scope.

Refer to the manufacturer standard warranty statement for more details on warranty conditions, scope and coverage.

## Contact Us

PoolPak  
5685 Rue Cypihot,  
Saint-Laurent QC  
H4S1R3,  
Canada  
[PoolPak.com](http://PoolPak.com)

1-833-DAS-POOL (327-7665)

Schedule / Modify a Start-up:

[Startups@DehumidifiedAirServices.com](mailto:Startups@DehumidifiedAirServices.com)

Inquire about Warranty:

[Warranty@DehumidifiedAirServices.com](mailto:Warranty@DehumidifiedAirServices.com)

Order Parts:

[Parts@DehumidifiedAirServices.com](mailto:Parts@DehumidifiedAirServices.com)

All Other Product Support:

[Support@DehumidifiedAirServices.com](mailto:Support@DehumidifiedAirServices.com)

## Delivery and Storage.

### Receiving Checklist

It is highly recommended to thoroughly check for both visible and concealed damage upon the equipment arrival and before signing the receiving papers.

As applicable:

- ✓ Visually inspect exterior of the equipment for damages (scratches, dents, missing elements, etc.)
- ✓ Verify the proper operation of latches and hinges on all access doors and panels
- ✓ Inspect all coils for damage to the fin surface coating, headers or coil connections
- ✓ Inspect the fan housings for any foreign objects
- ✓ Inspect and test all piping for possible shipping damage
- ✓ Check the tightness of bolts, screws and other fasteners

### Shipping Damage Handling

Manufacturer standard shipping term is FOB (freight on board), meaning that the equipment belongs to the customer as soon as the delivery truck leaves the factory.

**Note:** manufacturer is not responsible for any shipping damage. Should the equipment arrive damaged, follow the instructions below to resolve the situation. Delivery cannot be refused on the basis of shipping damage.

#### **Shipping Damage Handling Instructions:**

- ✓ Note the damage in detail on the freight bill and bill of lading.
- ✓ Take clear photographs of the damaged components, areas, portions of the equipment etc.
- ✓ Obtain a claim form from the carrier, fill it out, and return it promptly. Report all claims of shipping damage to the carrier immediately and coordinate a carrier inspection if necessary.
- ✓ Contact manufacturer Customer Support team (see **Contact Us** above) to notify of the noted damage.
  - Have the equipment serial number on hand to provide to Customer Support. The serial number can be found on the equipment's main label or bill of lading.
  - **Note:** it is the receiver's responsibility to provide reasonable evidence that damage was not incurred after delivery.
  - Do not attempt to repair the equipment without consulting with manufacturer Customer Support team.

## Storage

- Shipping protection material is provided by the manufacturer for shipping purposes only!
- If long-term storage is required, warranty aspect should be considered. Refer to the **Warranty** section of **Operation and Maintenance Manual** for more details. Please contact manufacturer should there be any questions.

## Mechanical Installation

**⚠️ WARNING!** All work must be done by qualified personnel in accordance with local and national Codes, Standards and Regulations as well as respective design and submittal documentation and manufacturer recommendations.

**⚠️ CAUTION!** Obtain all necessary documentation (manufacturer manual(s), submittal documentation, drawings, etc.) and familiarise yourself with it before performing installation or any other related tasks.

## Lifting and Rigging

**⚠️ WARNING!** Lifting and rigging must be done by trained professionals in accordance with proper lifting techniques and safety procedures. Proper lifting machinery and tools and safety equipment (PPE) must be used. Improper lifting may cause equipment damage, serious injury, or death. Manufacturer is not responsible for the improper use of lifting equipment or improper lifting practice.

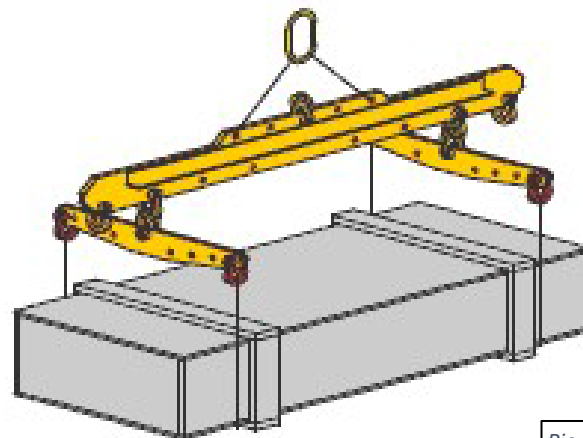

Pic. E.1

- ✓ Use spreader bars for lifting to prevent equipment damage.
  - Spreader bar usage/positioning, shown on Pic. E.1, is only an example! Determine spreader bar set up (configuration, cables location/positioning etc.) based on the particular equipment to be lifted.
  - Use equipment lifting brackets at the base frame.
- ✓ Each of the lifting cables (chains or slings) must be capable to support the weight of the entire equipment.
- ✓ Determine the approximate centre of gravity before lifting. See equipment design drawings in the submittal documents for the total weight and weight distribution.
- ✓ Lifting cables (chains or slings) may not be of the same length. Adjust as necessary for an even lift.
- ✓ Do not lift equipment in windy conditions.
- ✓ Do not raise equipment overhead with personnel below.
- ✓ Test lift the equipment 24 inches to verify proper operation of lifting machinery and positioning of lift points such that the lifted equipment is level.

## General Mechanical Installation Requirements

Equipment should be installed in accordance with respective local Codes and Regulations as well as applicable submittal documentation.

**NOTE.** For equipment-specific data (dimensions, clearances, accessibility, etc.) refer to equipment submittal documentation, **Operation and Maintenance Manual**, and equipment labels and stickers.

## General Placement of the Equipment

- ✓ Equipment must be installed on a firm, levelled surface, with provision for vibration absorption.
- ✓ **Service and operational clearances** to the equipment must be always maintained:
  - Access to ALL doors, panels, covers, valves, disconnects etc. must not be restricted. Some installations may require cat-walks or other means of access to otherwise restricted side of the equipment.
  - *General Clearance: up to 36"* all around and **up to 96"** above fan(s) for proper operation, service and maintenance (for equipment-specific data, refer to respective submittal documentation).
  - Equipment **installed in a pit** (surrounded on all four sides by walls, structures, etc. – see Pic. E.2):
    - Avoid such installation as much as possible!
    - If such installation cannot be avoided, the following must be maintained:
      - the min. clearances must be increased to double width of the equipment all around;
      - surrounding structures' height must not exceed the height of the equipment.
- ✓ **Anchor** (secure, fasten etc.) light-weighted equipment to the horizontal mounted surface (concrete pad etc.).
  - This applies mostly to NG series fluid coolers models NG-Z, NG-V-01, NG-V-02, NG-V-11 and NG-V-12.

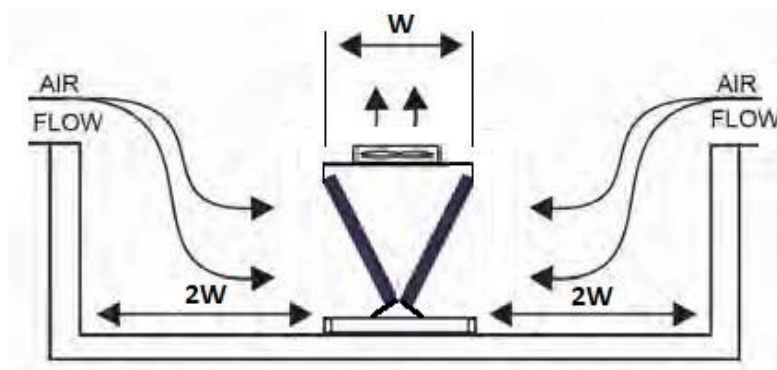

Pic. E.2

**NOTE:** distance between the fluid cooler and the other equipment it serves affects the connecting **pipe line set** (length, size etc.). Consider it prior to finalizing the placement of

the equipment! Before placing the equipment, ensure that resulting pipe set selection (length, diameters etc.) are acceptable.

**NOTE.** Do NOT exceed distance limitation between the fluid cooler and equipment it serves – it may result in equipment incorrect operation and/or failure. Before finalizing the fluid cooler placement/location, refer to respective equipment data (including submittal documentation) and **Equipment Piping** chapter of current manual (see further). Contact the manufacturer if needed.

## Mechanical Installation – Special Cases

The placement requirements outlined above apply to all models of NG series fluid coolers.

### Model NG-Z Fluid Coolers' Mounting/Support Set Field Assembly

The **NG-Z** model fluid coolers can be provided in vertical or horizontal airflow configuration and may require field assembly of respective mounting/support set (legs):

**Vertical airflow configuration** (for mounting on a horizontal surface such as ground, roof, etc.) – see Pic. E.3:

- ✓ Uncrate/unwrap the equipment and legs.
- ✓ Install the four provided legs (a) onto the equipment (leg is to be placed inside in the corner) o Double cooler (b) would have six legs provided – place two additional legs in the middle – refer to picture.
- ✓ Align all four holes in each leg and equipment corner and attach legs with provided bolts, washers (legs have factory-installed nut-certs); tighten all bolts.
- ✓ Ensure that the cooler is levelled and firm; affix the legs to the surface (concrete slab, etc.); anchors/fasteners for surface mounting are NOT included.



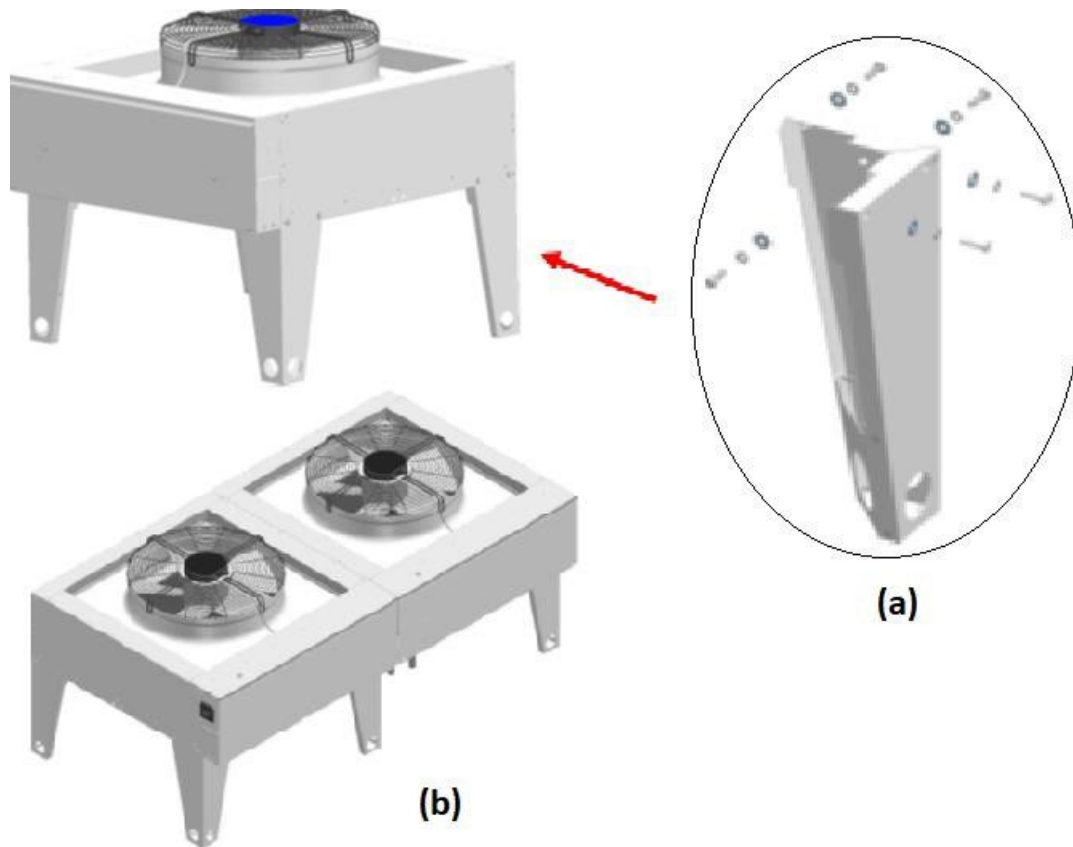

Pic. E.3

**Horizontal airflow configuration** *(for mounting on a vertical surface such as wall etc)* - see Pic. E.4. In this case, use the same mount kit as above. Note that the mount legs are assembled slightly differently.

- ✓ Uncrate/unwrap the equipment and mounting kit.
- ✓ Assemble left and right mount legs as shown with provided bolts, nuts, and washers (except for joint point (a) – it must be bolted to the cooler box)
- ✓ Align respective holes in cross-piece (b) and the holes in the equipment and attach them with provided bolts, nuts, and washers.
- ✓ Attach rear support braces to the cooler with provided self-tapping
- ✓ screws (d) Ensure that the assembly is straight, square, and sturdy; tighten all bolts.
  - o Ensure that the cooler is levelled and firm; affix mount legs footings to the surface (wall, etc.); anchors/fasteners for surface mounting are NOT included.

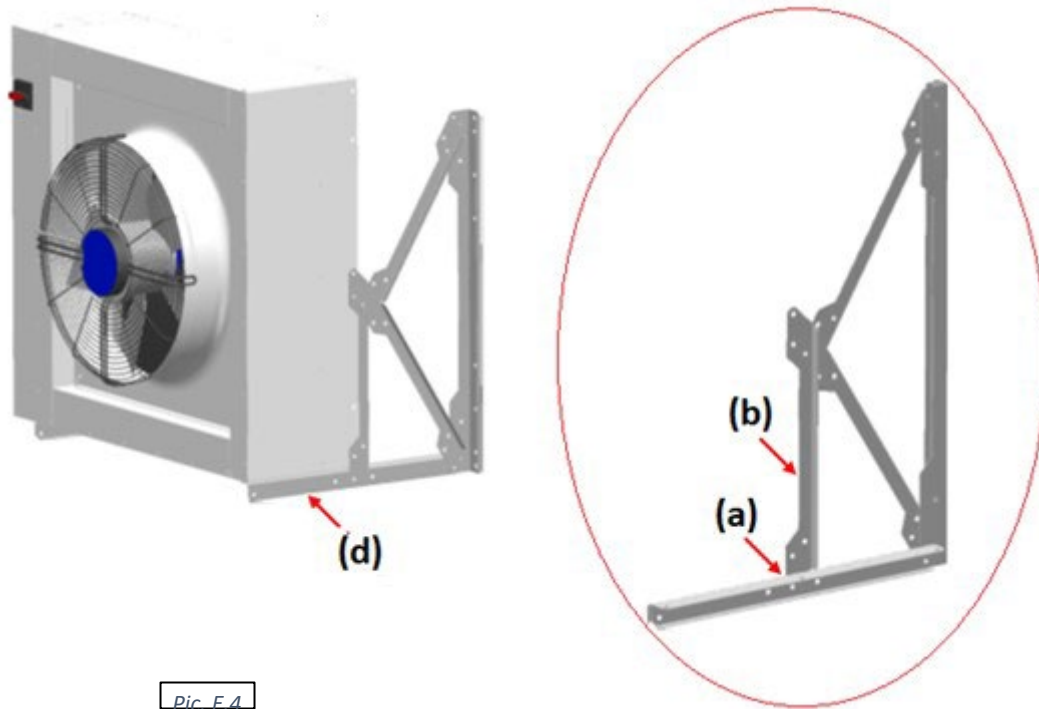

Pic. E.4

### ATTENTION! Cooling Fluid Lines Sweating!

Under certain conditions (namely – *when the cooling fluid lines' outer surface drops below dew point of the surrounding air, particularly inside the facility*), said lines may “sweat” as condensation forms on their surface. Should this occur, it is recommended to insulate the piping to prevent condensation.

### Piping Connection

**⚠ WARNING!** All work must be done by qualified personnel in accordance with local and national Codes, Standards and Regulations as well as respective design and submittal documentation and manufacturer recommendations.

**⚠ CAUTION!** When connecting the equipment to external mechanical and electrical systems, refer to submittal documentation and equipment labels and stickers for piping connection details.

### Piping General Considerations

- Refer to the equipment main label and stickers at lines/piping termination to verify respective **connecting lines' sizes, flow directions** (IN/OUT) and **media type** (water, glycol/water mixture and ratio etc.) o Flow direction stickers at respective piping

stubs refer to the equipment it's attached to: **IN** – media (water, glycol etc.) **entering** the equipment, **OUT** – **leaving** the equipment.

- o Select the line/piping size based on the equipment documentation (labels, drawings, etc.). Note that diameters of the piping stubs/connections may be different from the required line size.
- Use proper **materials** and **pipe joining methods**, respective to given system (system media, pressure, etc.). Use proper **installation field practices** and **Code(s) requirements** (proper piping support, no pipe-to-edge contact, grounding/bonding, insulation, pressure testing, charging/filling, etc.)
- As/where needed, ensure that proper **isolation** and **balancing** means (valves, circuit setters, etc.) are in place. Provide proper means for **priming** (filling), **draining** and **aerating** (bleeding the air from the system): install automatic air bleeding valve(s) at each local top point of the system and drain/priming valves at the lowest point(s) of the system.

## Line Set Selection and Sizing

- Refer to fluid cooler (and/or equipment it serves) data (main label etc.) for line set **typical diameter** (both lines, supply and return, are normally of the same size).
  - o **Typical** line set **diameter** accounts for system proper operation if line set **total equivalent length** does not exceed (approx.):
    - 200' – for NG-V-02 fluid cooler model\*
    - 300' – for NG-V-12 fluid cooler model
    - 450' – for other fluid cooler models
  - o If the total equivalent length exceeds above value, the line set diameter must be increased to next size (e.g., step up diameter from 1 ¼" to 1 ½"). Contact the manufacturer for more details, if needed\*\*.
- \* in some cases, *NG-V-02 fluid cooler model may accommodate higher **total equivalent length** with **typical diameter** – contact the manufacturer for details.*
- \*\* *typically, the fluid cooler is either provided with the pump package or serves the equipment, equipped with its own pump, therefore no additional pump is needed. However, in some cases additional pump may be required. Contact the manufacturer if needed.*
- Standard recommended pipe and fitting materials are PVC, steel and copper. Other materials may also be suitable – refer to material applicability according to given application (system media, max working pressure, temperature, etc.).

## Piping

- ✓ Ensure proper piping support and bracing is in place – fluid cooler pipe terminations do not provide structural support for pipe line set.
- ✓ Follow proper piping practices (cleaning, sanding, reaming, wet-ragging during soldering, etc.) and bonding methods, respective to pipe and fittings material (soft soldering, gluing, etc.).
- ✓ Install valves/devices to isolate, drain, charge and remove the air from the fluid cooler and line set.
  - Fluid cooler typically is not provided with isolating valves – install as needed.
  - Install drain/charge valve(s) at the lowest point(s) of the line set and the equipment; install air bleeding valve(s) at the top point(s) of the line set (see Pic. G.1(A) and (B)); fluid cooler would typically have drain/charge valves installed at their lowest point(s).
  - Pump package (if fluid cooler is equipped with or provided separately with one) typically includes pump with pressure gauges and expansion tank; otherwise – determine, if the circuit requires expansion tank and other devices.

Pic. G.1 (A) shows typical piping schematic for single fluid cooler serving single system/cooling circuit. Piping schematic for single fluid cooler serving multiple systems/cooling circuits is shown on Pic. G.1 (B).

**NOTE:** the given schematics are example only - the design, provision and installation of actual fluid cooler piping is not manufacturer's responsibility and is to be done by a third party. Pic. G.1 (A)

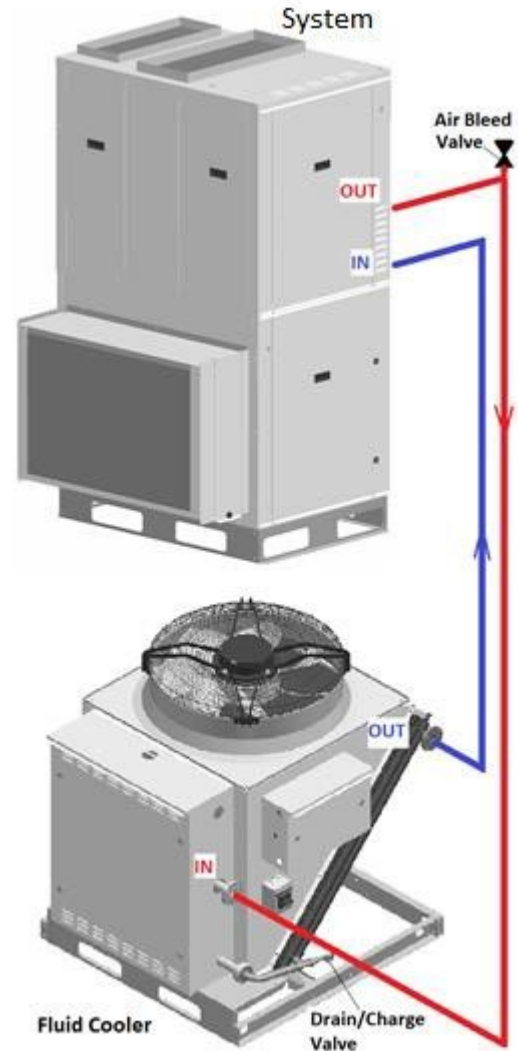

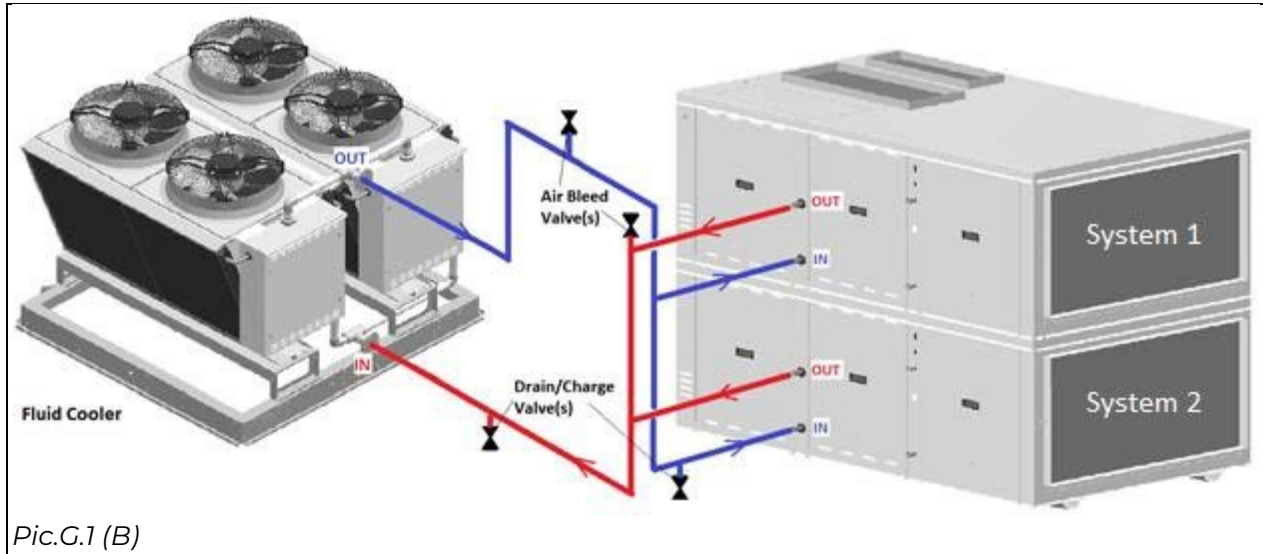

### Pressure Testing and Charging

- Refer to the fluid cooler (and/or equipment it serves) data (main label, submittal documentation etc.) for **operating pressure** and **cooling media** selection.
  - One of the typical media is a mixture of food grade **propylene glycol** (with rust inhibitors added) and **distilled water** is used as a cooling fluid. The mixing ratio is typically **30-35% glycol**; however, a higher glycol concentration (e.g., 50%) could be used for northern application – refer to the equipment submittal documentation.
  - To calculate approximate (!) Total System Volume (amount of fluid required for system charging), add *Internal Fluid Cooler Volume* (see submittal documentation) to *Line Set Volume* (calculate based on the used pipe diameter and line set actual length). Increase calculated Total System Volume by 3-5% - final charge of the system would be determined during the charging (see below).
- Charge system at its lowest point and bleed the air out at the system top point(s); depending on the circuit configuration, charging at multiple lowest points (at fluid cooler and the equipment it serves) may be required.
  - Use a separate **charging pump**. The fluid cooler pump(s) (if present) are selected/selected to maintain fluid circulation and not be used for charging. Ensure fluid is clean, free of any debris etc.
  - Ensure thorough air removal from the circuit – airlocks will prevent system from operating properly.
  - Ensure that static pressure at the highest point of the system is at least 15-20 psi. Verify it after bleeding all the air from the system.

## Electrical Connection: Power and Control

**⚠️ WARNING!** All work must be done by qualified personnel in accordance with local and national Codes, Standards and Regulations as well as respective design and submittal documentation and manufacturer recommendations.

**⚠️ WARNING!** Refer to equipment electrical data (provided via main label, submittal documentation etc.) as well as equipment labels and stickers for selecting proper wire gauges, other electrical apparatuses and wiring connection details.

**⚠️ CAUTION!** Use **copper** conductors only. Equipment electrical and control terminals are not designed to accept other types of conductors. Use of aluminium or other wiring may result in galvanic corrosion and/or overheating that may cause equipment malfunction and/or failure and would void the warranty.

### Electrical Connection General Considerations

- Select power supply wire gauge and, as/when needed, external power apparatuses (disconnects, breakers, etc.) according to equipment electric data (MCA, MOP, etc.), provided on the main label, as well as respective local and national codes and regulations.
- Equipment is provided with its respective wiring diagrams, depicting equipment internal wiring and terminals for external connection (power supply, control terminals, etc.) – refer as needed.
- Properly seal all penetrations made/used in the equipment panel/junction box. Failure to do so may result in water/humid air infiltration that could lead to equipment's electrical apparatuses malfunction or damage.
  - Ensure that all metal shards and filings are swept to avoid possible corrosion or damage to electrical components. Ensure that wires are properly protected/isolated from the equipment cabinet sharp edges, hot surfaces, etc.

### Equipment Main Power Connection

- Connect main ("high") power for the equipment to its disconnect **(a)** (if equipped with one – see Pic. H.1) - disconnect would be factory-wired to the PDB (power distribution block) **(c)** directly; if equipment does not have disconnect, connect power to the PDB **(c)**, located in the main electric panel **(b)**.
  - Multi-"V" fluid coolers would have multiple factory-wired electric panels **(f)** – all panels would be connected in parallel; only one dedicated (main) panel to be used for external power connection.
  - If fluid cooler is equipped with pump package(s), said package would be typically factory-wired – power for the pump would be brought from respective electric panel of each "V" block.
- Verify that proper voltage and number of wires (single -phase Vs three-phase – see Pic.) are connected to the equipment – refer to the equipment main label and submittal documentation.



**NOTE:** Typically, fluid cooler wiring diagrams, depicting both, high power and control wiring, is attached to the inner side of main electric panel cover. Refer as needed.

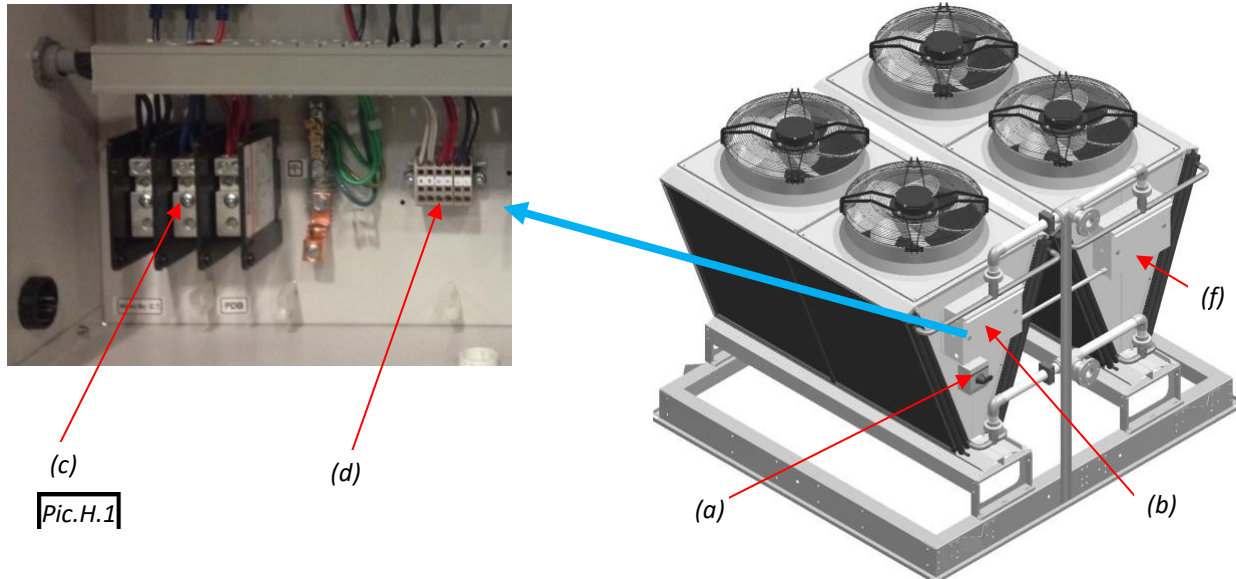

### Equipment Control Wiring Connection

- Connect control wiring to control terminal **(d)** in main electric panel.
  - Subsequent electric panel(s) and Pump Package(s) (if any) are factory-wired and do not, typically, require field wiring.
- Ensure proper wire selection - gauge, number of conductors, insulation/protection selection (exposure to cold weather, UV light, etc.)
  - Typically, copper wire gauge 18 multi-strand conductors is acceptable.
  - Refer to specific equipment info for number of conductors – refer to equipment-accompanied and field wiring diagrams. It is recommended to select a wire with one or two spare conductors. Refer to Fluid Cooler control arrangement – see below.

### Fluid Cooler Control Arrangement.

Depending on the application, equipment it's serving and some other factors, fluid cooler control set up could vary. Refer to specific fluid cooler documentation (submittal, wiring diagrams etc.):

- **Stand-Alone.** Fluid cooler is equipped with control system that operates its fan(s) and pump(s) without external control signal(s). In this case no external control wiring is required.
  - Typical example of said arrangement is fluid cooler equipped with aquastat, that monitors LFT (leaving fluid temperature) and respectively stages fluid cooler fan(s) to maintain it at certain level.
- **Externally controlled.** Fluid cooler is set to accept a control signal (may vary in type), based on which fluid cooler fan(s) and pump(s) would be activated/staged. In this case external control wiring must be brought from the controlling system according to the

fluid cooler wiring diagram. Refere to fluid cooler wiring diagram(s) to determine type of signal and number of conductors required.