



# **PPW SERIES**

## DEHUMIDIFIERS

OPERATION AND MAINTENANCE MANUAL

[PoolPak.com](http://PoolPak.com)

## Table of Content

<b>General Information</b>	<b>4</b>
• Operating Safety	4
• Reference and Additional Information	5
○ Contact Us	5
• Basic Information	6
○ Dehumidifier View and Options	6
○ Dehumidifier External Systems Connection	8
○ Equipment Specific Data	9
<b>Layout and Components</b>	<b>10</b>
• Dehumidifier Main Components	10
• Control System	12
<b>Sequence of Operation</b>	<b>13</b>
• Set Points	13
• Ventilation	13
○ Purge Option	13
○ Heat Recovery Option	14
• Air Conditioning and Dehumidification	14
○ Economiser Mode Option	14
• Space Heating	15
• Space Cooling	15
<b>Interface and Communication</b>	<b>16</b>
• Touch Display Operator Panel	16
○ Alarms	17
• Remote Communication	18
<b>Basic Maintenance</b>	<b>19</b>
• Maintenance and Safety	19
• Maintenance Key Points	19
• Routine Maintenance Program	20
• Specific Components Maintenance	20
<b>Warranty</b>	<b>22</b>

## General Information

This manual provides basic information about the applicable PoolPak dehumidifier and its operation.

Important information regarding installation, maintenance, and start up as well as additional and auxiliary systems and devices (outdoor condenser, communication interfaces, etc.) is normally provided with the dehumidifier and can also be obtained from the manufacturer (see **Contact Us** below).

## Operating Safety (Warnings, Cautions, and Notes)

### FOR YOUR SAFETY: READ BEFORE PERFORMING ANY OPERATIONS, MAINTENANCE OR SERVICE TASKS!



Only qualified technicians should install, operate, maintain or service mechanical equipment including current dehumidification system. Make sure to read this manual before performing any tasks to familiarize yourself with the equipment as well as with any potential hazards. Always exercise caution!



#### **Beware of electrical power and high electrical voltage!**

- Follow proper safety procedures – lockout, tagout, and other respective procedures
- Failure to follow safety procedures can result in serious injury or death



#### **Beware of moving parts and hot surfaces!**

- Make sure to stop all moving parts (fans, blowers, etc.) before accessing the equipment's internal space
- Be aware of hot surfaces (space heating pipes, coils, heaters, etc.)



#### **Beware of chemicals!**

- Some dehumidifiers may contain liquids such as glycol mixtures

The following warnings, cautions, and notes appear throughout this manual and referenced documentation whenever special care must be taken to avoid potential hazards that could result in equipment malfunction or damage, personal injury, or death.

 **WARNING**  
 Indicates a potentially hazardous situation which could result in serious injury or death if handled improperly.

 **CAUTION**  
 Indicates a potentially hazardous situation which could result in moderate injury or equipment damage if handled improperly.

**Note**  
 Indicates a situation that could result in equipment damage or improper/ineffective operation if handled improperly.

## Reference and Additional Information

For safe, efficient and problem-free operation, it is critical to handle the dehumidifier (as well as related systems and components) properly at each step - from receiving and storage to installation and start up. Relevant information can be found in the respective documents (like **Installation Manual**) provided with the dehumidifier.

This manual and other related documents could be obtained from the manufacturer (see **Contact Us** below).

### Attention: Installation and Service Contractors

 **WARNING!** Any work (installation, start up, service, maintenance, repair, etc.) on any mechanical equipment must be performed in accordance with respective manufacturer’s recommendations as well as submittal documentation, local Codes and Regulations, and appropriate field practices. Failure to do so could result in personal injury, equipment damage or malfunction, and will void equipment warranty. Only qualified and properly trained individuals should perform tasks on this equipment.

### Attention: Maintenance Team

 **CAUTION.** To ensure equipment longevity and proper and efficient operation, the dehumidifier and its auxiliary systems and devices should be maintained properly and regularly. Failure to do so could negatively affect premise comfort levels and people’s health. It could also lead to equipment damage, malfunction, premature tear and ware and may void equipment warranty.



## Contact Us

PoolPak  
5686 rue Cyphiot  
Saint-Laurent, Quebec H4S 1R3  
Canada  
PoolPak.com

1-833-DAS-POOL (327-7665)

Schedule / Modify a Start-up:

[Scheduling@DehumidifiedAirServices.com](mailto:Scheduling@DehumidifiedAirServices.com)

Inquire about Warranty:

[Warranty@DehumidifiedAirServices.com](mailto:Warranty@DehumidifiedAirServices.com)

Order Parts:

[Parts@DehumidifiedAirServices.com](mailto:Parts@DehumidifiedAirServices.com)

All Other Product Support:

[Support@DehumidifiedAirServices.com](mailto:Support@DehumidifiedAirServices.com)

## Basic Information

### Dehumidifier View and Options

PoolPak standard NV080 (BX cab) dehumidifier general views as well as some options are shown on Pic.C.1.

- Pic. C.1 shows only one example of dehumidifier arrangement – refer to submittal documentation for specific details.

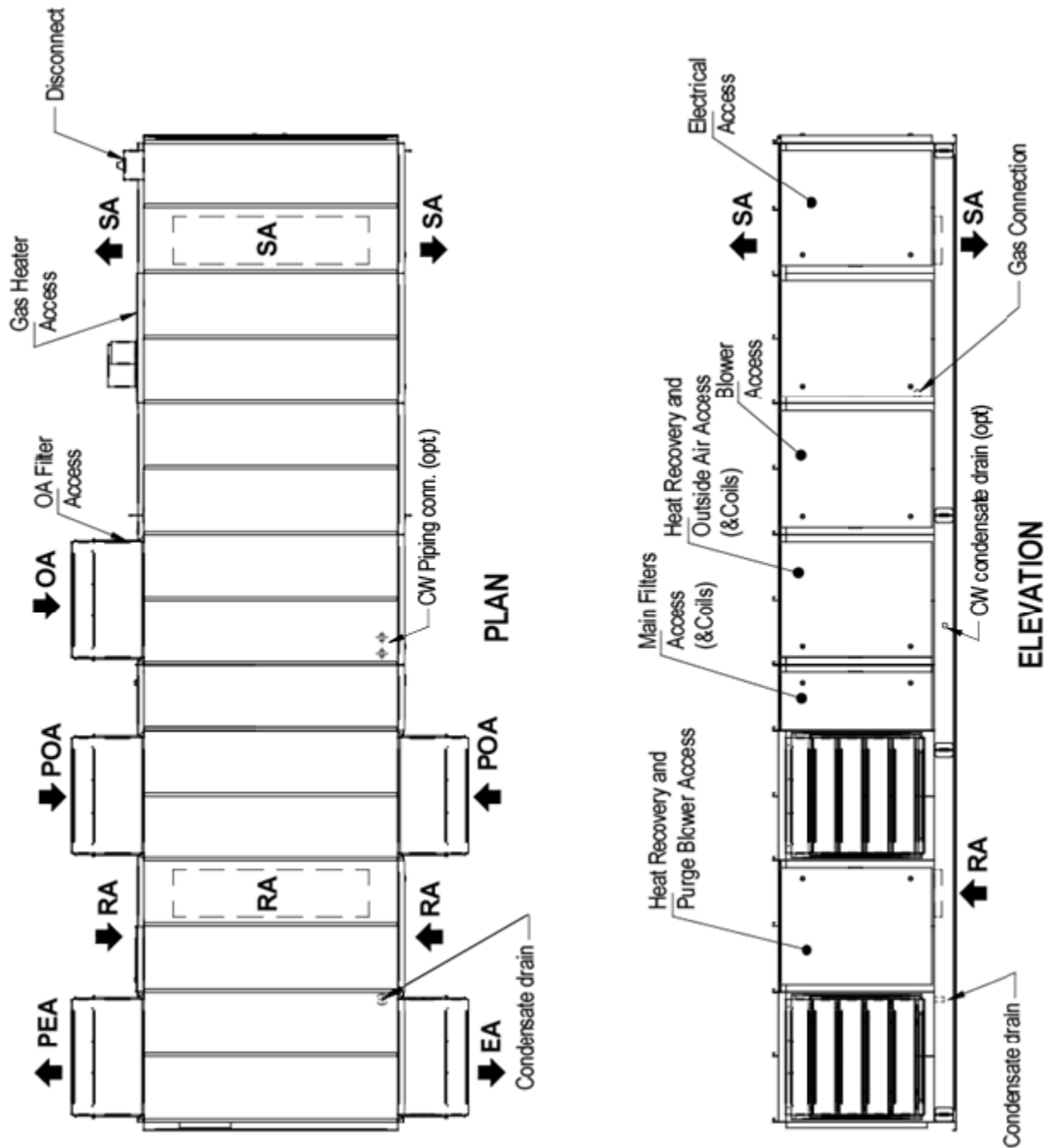

Pic. C.1

## NV Dehumidifier Options

- Indoor or outdoor installation.
  - Pic. C.1. shows outdoor model, equipped with louvers (to protect air intake and discharge openings from elements). Indoor model would have ducts connected to respective openings, no louvers would be needed.
- Cabinets capable of delivering supply and outside nominal airflows\* as follows:
  - NV-080, BX Cab, 8,000 CFM
  - NV-200, AA Cab, 20,000 CFM
  - NV-320, CC Cab, 32,000 CFM
  - NV-600, DD Cab, 64,000 CFM

\* At 1" ESP. Airflow capability varies depending on external static pressure.
- Airflow/ductwork connection options \* - as shown on Pic. C.1 and described below (some option locations availability depends on the dehumidifier installation – indoor or outdoor):
  - **Return Air (RA)** ductwork connection - top, bottom, end, sides.
  - **Supply Air (SA)** ductwork connection – top, bottom, sides.
  - **Min Outdoor Air (OA)** ductwork connection/termination – top, sides.
  - **Min Exhaust Fan (EF)** and **Purge Fan (PF)** ductwork connections/terminations – end, sides.
  - **Purge Outdoor Air (POA)** ductwork connection/termination - top, sides.
- Optional **Space Heating** - hot water coil, electric or gas heater \*\*.
- Optional **Space Cooling** – chilled water coil
- Optional **Heat Recovery** (HR) circuit.

\* All available options (ductwork connections, aux options etc.) are shown. Refer to the submittal and other relevant documentation for your dehumidifier's options.

\*\* For specific details on space heating (hot water, gas, electric) option, refer to the submittal and other documentation:

- **Gas-fired duct heater** can be installed internally (fitted inside the dehumidifier at the factory) or provided for field installation (to be fitted in the supply air ductwork).
- **Electric heater** or **hot water coil**, depending on capacity, model, size, etc., can be installed externally (mounted on the top of SA opening or fitted in the supply air ductwork) or internally. Refer to your dehumidifier's submittal documentation.

### Attention! Equipment Clearances and Dimensions!



**CAUTION!** For equipment proper operation, maintenance and service, respective clearances should be maintained. Generally, 30" clearances to the equipment must be kept for the maintenance and service purposes. For the specific required clearances information, as well as dehumidifier overall dimensions, distances to pipe connections, duct connections etc., refer to the submittal documentation.

## PPW Dehumidifier Options

- Indoor or outdoor installation.
  - Pic. C.1. shows an outdoor model, equipped with louvers (to protect air intake and discharge openings from elements). Indoor model would have ducts connected to respective openings, no louvers would be needed.
- PPW units have chilled water coils for dehumidification instead of evaporators, typical airflow capacities by cabinet are listed below:
  - PPW-120, 30 tons (CxA, 20,000)
  - PPW-260, 64 tons (CxC, 34,000)
  - PPW-340, 80 tons (DxC, 64,000)
  - PPW-530, 128 tons (DxG, 64,000)

\* At 1" ESP. Airflow capability varies depending on external static pressure.
- Space Dehumidification via Chilled Water Coils – capacities vary depending on water plant chiller capabilities
- Airflow/ductwork connection options \* - as shown on Pic. C.1 and described below (some option locations availability depends on the dehumidifier installation – indoor or outdoor):
  - **Return Air (RA)** ductwork connection - top, bottom, end, sides.
  - **Supply Air (SA)** ductwork connection – top, bottom, sides.
  - **Min Outdoor Air (OA)** ductwork connection/termination – top, sides.
  - **Min Exhaust Fan (EF)** and **Purge Fan (PF)** ductwork connections/terminations – end, sides.
  - **Purge Outdoor Air (POA)** ductwork connection/termination - top, sides.
- Optional **Space Heating** - hot water coil, electric or gas heater \*\*.
- Optional **Heat Recovery** (HR) circuit.

\* All available options (ductwork connections, aux options etc.) are shown. Refer to the submittal and other relevant documentation for your dehumidifier's options.

\*\* For specific details on space heating (hot water, gas, electric) option, refer to the submittal and other documentation:

- **Gas-fired duct heater** can be installed internally (fitted inside the dehumidifier at the factory) or provided for field installation (to be fitted in the supply air ductwork).
- **Electric heater** or **hot water coil**, depending on capacity, model, size, etc., can be installed externally (mounted on the top of SA opening or fitted in the supply air ductwork) or internally. Refer to your dehumidifier's submittal documentation.

### Attention! Equipment Clearances and Dimensions!



**CAUTION!** For equipment proper operation, maintenance and service, respective clearances should be maintained. Generally, 30" clearances to the equipment must be kept for the maintenance and service purposes. For the specific required clearances information, as well as dehumidifier overall dimensions, distances to pipe connections, duct connections etc., refer to the submittal documentation.



## Dehumidifier External Systems Connection

Pic. C.1 shows provisions for external systems connections, including ductwork, electric power and control wires and various piping connections.

**CAUTION!** This manual shows general/default connections' location. For details regarding specific dehumidifier's connections (actual location, piping sizes and position dimensions, circuit type and flow direction etc.), refer to the dehumidifier's submittal documentation as well as dehumidifier's labels and stickers.

- ✓ All of the below piping systems are optional and may not be present in each dehumidifier.

- **Condensate Drain Line (heat recovery)** – bottom, side (through the dehumidifier base).

**NOTE.** Dehumidifier **MUST** be equipped with a P-trap at the condensate connection for proper operation! If dehumidifier is requested from the factory without P-trap, one **MUST** be installed on site prior to dehumidifier being commissioned. Refer to the **Installation Manual** for details.

- **Space Cooling connection** – bottom, side.
- **Space Heating (Hot Water connection)** – bottom, side.
  - Some connection location options, for heating pipe lines, are limited to indoor installation only – refer to submittal documentation
- **Space Heating (Gas Heater connection, gas line).** If the dehumidifier is equipped with a gas heater (e.g. gas furnace) for space heating purposes, the **gas** line connection is to be brought to the gas heater directly.

 **WARNING! Gas Line.** The gas line must be installed in accordance with respective device documentation and local codes and regulations.

- **Electric Power and Control Connection.** Electric power is normally brought to the dehumidifier disconnect (see Pic. C.1). If dehumidifier is not equipped with it, power lines to be brought directly to the main electric panel. Also, provisions are made to bring control and communication connections through the dehumidifier roof at the service vestibule.

## Equipment Specific Data

Specific information for individual dehumidifiers is provided in the following methods:

**Main Label** (Pic. C.5): the manufacturer tag attached to the front of the dehumidifier includes the dehumidifier's most critical data:

- ✓ General data including:
  - Serial number
  - Dehumidifier model (nomenclature)
  - Design room conditions (air temperature and humidity)
  - Heat recovery glycol type & charge
- ✓ Operational data, including:
  - Electrical & airflow data (dehumidifier voltage, CFM, etc.)
  - Auxilliary system data (e.g. auxilliary heating)

PoolPak®				
<b>General Data</b>				
Serial Number : 16094015				
Unit Model : PCP-1400-PB-X-P3NB1162G2C4AD3				
Condenser Model : NC-B-1V-CUC-S				
Application : OUTDOOR USE				
Design Room Conditions : 75 °F 54 % R.H.				
<b>Refrigeration Data</b>				
Refrigerant Type : R410A				
Factory Charge (CKT 1) : 21 lbs Oil Charge (CKT 1) : 11 oz POE				
High Pressure Cutout (Switch) : 600 psig				
Low Pressure Cutout (Switch) : 50 psig				
<b>Electrical &amp; Airflow Data</b>				
MCA (Minimum Wire Size) : 30.0 Use Copper Conductors Only				
MOP (Max Fuse or CKT BKR) : 45.0 System Voltage : 208/3/60				
<small>(HACR type NEC)</small>				
	Qty	Voltage	CFM	HP FLA
Supply Motor :	1	208/3/60	1600	2.2 5.0
Outdoor Air Intake :	-		400	- -
OACC Blower Motor :	1	208/1/60	-	0.6 2.6
Gas Heating Package :	1		-	- -
	Qty		LRA	RLA
Compressor Motor :	1		123.0	17.6
<b>Pool Heating Data</b>				
Pool Water Flow (Total) : 7.0 GPM Pressure Drop : 3.0 psi				
Max. Inlet Pressure : 60.0 psi Connection Size : 0.75 NPT				
<b>Auxiliary Heating Data</b>				
Gas Heater Output : 80 MBH Gas Connection Size : 0.75 NPT				
Gas Pressure Input (Min/Max) : 7.0 / 14.0 in-H2O				
Boiler Loop Capacity : 7 U.S. Gal. 33% Propylene Glycol				
www.poolpak.com				MADE IN USA

**Labels and Stickers:** attached when applicable to the exterior and interior of the dehumidifier to show:

- ✓ External systems connections location/direction (space heating, space cooling, condensate)
- ✓ Air filter locations, quantity, and size.
- ✓ Additional Info (warning, caution stickers, etc.)

Pic. C.5

**Wiring Diagrams:** attached to the interior side of the dehumidifier, depict dehumidifier control and power wiring.

**Note:** The main label shown above is just an example.

### Attention! Glycol Circuits.

Unless otherwise indicated, equipment that is equipped with heat recovery option contains a heat recovery circuit that is factory-charge with a water/glycol mixture; normally, rust inhibitor-infused food-grade propylene glycol is used.

Glycol mixture concentration is normally shown on Main Label – refer as needed.

## Layout and Components

The general layout and components location is the same for all dehumidifiers of current type, however some may vary, based on the dehumidifier's specific options – refer to submittal documentation. Pic. D.1 below shows all/most available options for the NV-080 (BX cab), some of which may not be present on your dehumidifier.

### Dehumidifier Main Components

- **Main Blower** (1) is in the main blower compartment downstream of the min outdoor air opening.
- **Main Electric Panel** (2) is typically on the supply end. Some models are equipped with multiple main blowers.
- **Min Outdoor Air (OA) Opening** (4) is optionally equipped with a motorized damper and filter(s). The **Manual OA Damper** (5) is usually used to set proper amount of outdoor air intake; in some cases, it could be equipped with modulating actuator for automatic adjustment of outdoor air intake.
  - Outdoor-installed dehumidifier would have **louver(s)** (76) installed at the OA opening.
- Optional **Min Exhaust Fan (EF) Assembly** (6) (fan and motorized damper) is located on the dehumidifier's return air side; Exhaust Air opening in outdoor-installed dehumidifier is equipped with **louver(s)** (76) also.
  - Min Exhaust Fan Assembly is hinged and could be opened for better access to the fan electric box.
- Dehumidifier, equipped with **Heat Recovery (HR)** option, would have **HR glycol coils** (71), installed at **the Min Exhaust (EF)** and **Min Outdoor Air (OA)** openings, and **HR pump** (72), installed in return air compartment.
  - If HR option is present, **Min Exhaust Fan Assembly** would normally be equipped with a filter rack.
- If dehumidifier is equipped with **Purge** option, additional **Purge-exhaust fan (PF)** (73) with motorized damper would be installed on dehumidifier's return air side, as well as additional ("**Purge**") **Outdoor Air (POA)** (74) opening(s), equipped with motorized dampers, would be located directly upstream of **Main Filter Rack** (9). Motorized **Return Air (RA) damper** (75) would be located between return air side and POA opening(s).
  - Outdoor- installed dehumidifier would have **louvers** (76) installed at the **Purge-exhaust fan** and **Purge Outdoor Air** openings.
- **Main Filter Rack** (9) is downstream of POA openings to protect downstream hot water or chilled water coils.
- **Space Cooling** (10b), typically located downstream of the **main filter rack**. For NV models, this option is for sensible cooling only while the PPW also uses this coil for Space Dehumidification.
- **Space heater** (11a and 11b) location, if the dehumidifier is equipped with one, may vary:
  - **Hot water coil** or **Electric heater** (11a) is usually located downstream of the **main filter rack**;
  - **Gas heater** (11b) is usually located immediately after the main blower(s), however, in some cases it could be installed externally.
- **Main Electric Panel** contains **Main Control Board** (17), **Operator Panel** (18) and other electrical components. **Disconnect** (77), if one is installed, is usually located on the outer wall, opposite to **Main Electric Panel**.

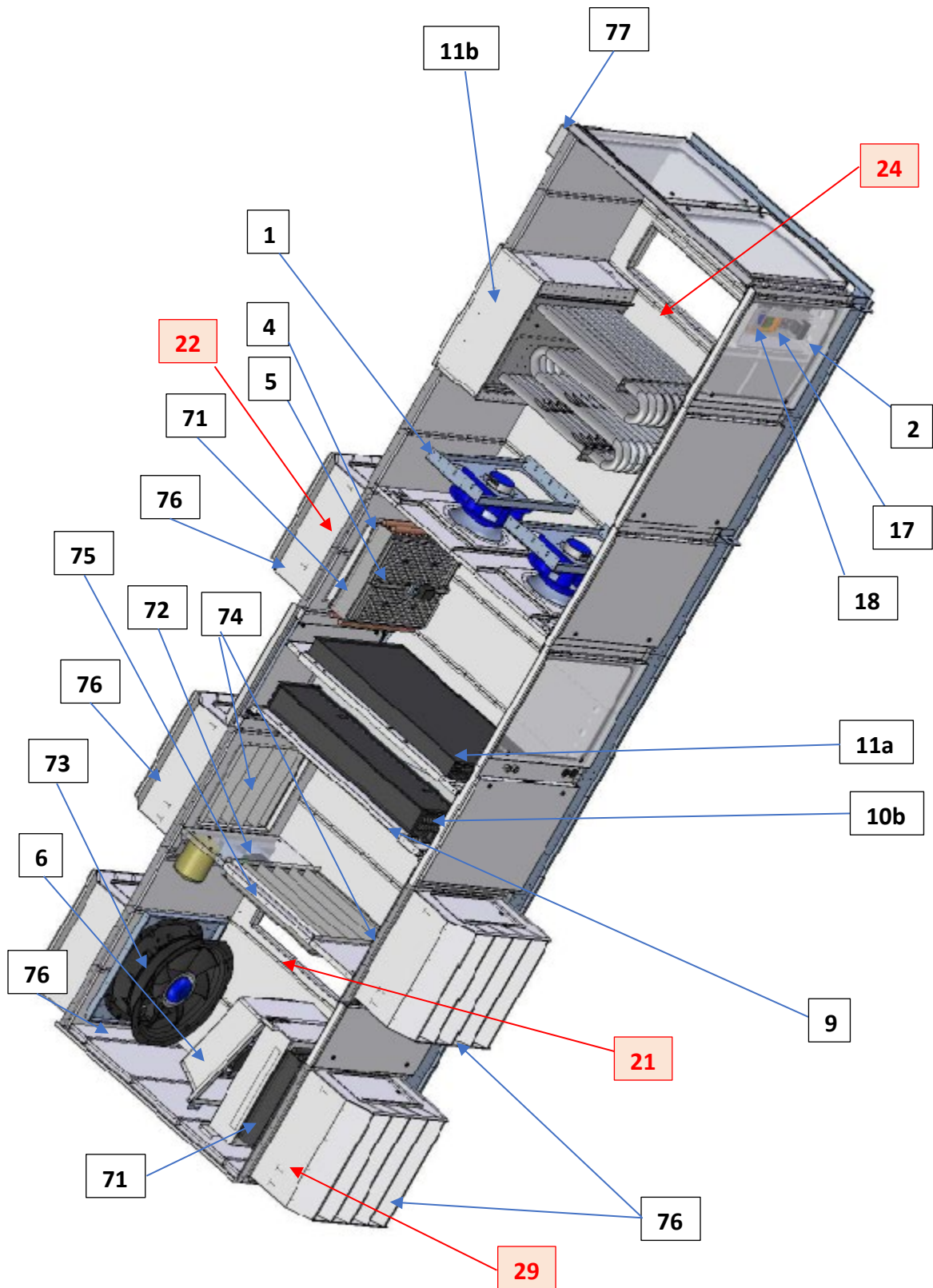

Pic. D.1

## Control System

The dehumidifier control system is composed of sensors, spread throughout the dehumidifier, **Main Control Board**, **Operator Panel** and other electric components, located in the **Main Electric Panel**.

**Temperature Sensors** (Pic. D.2):

- a) **Temperature** sensors (thermistors) are used to monitor air and water temperature;
- b) **Combo** sensor is used to monitor air temperature and humidity.



Sensors and safeties approximate location is shown on Pic. D.1 in red.

- **RA Combo Sensor (21)** measures temperature and humidity of the pool room air (Return Air) entering the dehumidifier. It is located at the return air ductwork connection to the dehumidifier.
- **OA Temperature Sensor (22)** measures outdoor air temperature; it's located at the OA filter rack.
- As an option, the combo sensor (instead of regular thermistor) can be installed at the OA intake to measure both the temperature and humidity of the outdoor air.
- **SA temperature sensor (24)** measures the temperature of the air leaving the dehumidifier (supplied to the premise). It must be located downstream of the space heater:
  - In some cases, where the space heater is external to dehumidifier, the sensor will be provided with the dehumidifier to be field-mounted into the supply air ductwork downstream of the space heater.
- If dehumidifier is equipped with **Heat Recovery** option, it could also have **Exhaust Air (EA) Temperature Sensor (29)**, installed downstream of exhaust-side located heat recovery glycol coil.
- **Main Electric Panel**, apart from devices listed above (control board, OP, etc.) also contains **Voltage Monitor**; some optional control sensors and devices such as an air pressure differential sensor, current sensor(s). It may also be located in main electrical panel or in the dehumidifier in general.

## Sequence of Operation

The dehumidifier's ventilation system establishes the required airflow through the dehumidifier. The control system compares air temperature and humidity to their desired values (set points) and proceeds to dehumidify, cool or heat the recirculating air.

### Set Points

The control system is constantly adjusting unit operation to achieve and maintain said parameters within couple degrees/percent of the set point.

Refer to the dehumidifier's main label for the design value of control parameters, as well as the following note.

**Note:** To ensure the dehumidifier's most economical operation, we recommend maintaining the following relationship between pool water and room air temperatures:

$$\text{Room Air T} = \text{Pool Water T} + 2^{\circ} \text{F}$$

### Ventilation.

The **main blower** runs continuously, establishing required. The main blower speed is pre-set via adjustable variable signal.

**Minimum Exhaust Fan (EF)**, if dehumidifier is equipped with such option, directs portion of return air outdoors. Like main blower, exhaust fan(s) speed is also controlled via adjustable (pre-set) variable signal, that varies based on scheduled ventilation mode (Occupied, Non-Occupied and Spectator) or call for Economiser Mode (as part of Air Conditioning and/or Dehumidification operation).

**Minimum Outdoor Air (OA) damper**, if dehumidifier is equipped with such option, opens to introduce fresh outdoor air into the premise. OA damper could be equipped with ON/OFF (simple fully open – fully closed) or modulating-controlled actuator; latter one would be controlled same way as minimum exhaust fan.

### Purge (Additional Exhaust) Option.

Along with **Min Exhaust Fan** and **Min Outdoor Air** damper, dehumidifier could have additional set of **exhaust (purge) fan(s)** (PF) and **purge outdoor air damper** (POA), commonly referred as **Purge**. Purge fan(s) and OA damper(s) function is to allow for higher exhaust and fresh air amount, up to complete (100%) air changeover (when all exhaust fans and OA dampers are at their max capacities).

**Purge Fan(s)** and **Purge Outdoor Air** damper(s) are controlled in the same fashion as **min exhaust fans** and **min outdoor air**. Some dehumidifiers may be equipped with additional **Return Air** damper: it closes in event of complete air changeover, separating return air side of dehumidifier from supply side (refer to **Layout and Components** chapter, as needed, for respective devices' location).

Complete air changeover, triggered manually, is known as **Purge Mode**.



- **Note.** Externally installed Exhaust Fan(s) and Outdoor Air damper(s) could be also controlled by the dehumidifier control system. This applies to both, **Minimum** and **Purge/Additional**, fans and dampers.

**Heat Recovery Option.**

Dehumidifiers, packaged with Minimum Exhaust Fan and Minimum Outdoor Air damper, could also have additional **Heat Recovery** (HR) closed-loop glycol system.

**Heat Recovery** loop (see Pic. E.1 below) consists of two coils (air-to-glycol heat exchangers) and a pump, establishing glycol circulation between them. One coil, installed at exhaust air opening, recovers portion of exhausted air energy, another coil, installed at outdoor air intake, transfers this captured energy to entering outdoor air.

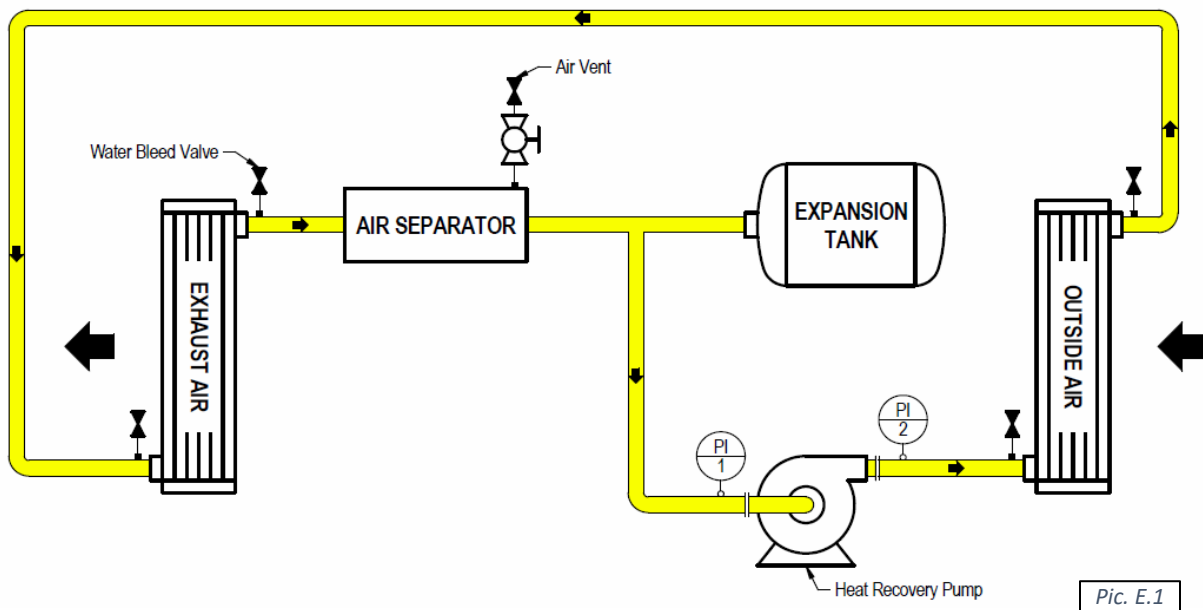

Pic. E.1

**Air Conditioning and Dehumidification**

When premise air temperature goes over (exceeds) its set point, the dehumidifier control system issues a call for Air Conditioning Mode. Respectively, when premise air humidity goes over (exceeds) its set point, the dehumidifier control system issues a call for Dehumidification Mode. In some instances, these calls may co-exist.

To execute Dehumidification or Air Conditioning (Cooling) mode, control system, depending on current conditions, would resort to available means of cooling or dehumidification.

**Economiser Mode Option.**

**Note:** Economiser Mode requires dehumidifier to be equipped with full (min and additional) exhaust and outdoor air options!

If outdoor air is dry and/or cool, it could be used to dehumidify and/or cool the premise. In this case, on call for Dehumidification or Air Conditioning mode(s), control system would simply increase exhaust fan(s) speed signal to direct more stale return air outside and bring in more outdoor (dry/cool) air in, thus reducing supply air humidity and/or temperature (as needed).

## Chilled Water Dehumidification – PPW only

Upon receiving dehumidification demand signal, the chilled water coil control valve actuator(s) will be engaged for space dehumidification and cooling. The chilled water control valve(s) will stage coil operation as needed based on return air relative humidity.

## Space Heating

When premise air temperature drops below the set point, the dehumidifier control system issues a call for Space Heating Mode and engages space heater (electric heater, hot water coil with valve, gas boiler etc.) by sending space heating signal, respective to space heater control type - on/off, variable (0-10VDC), etc.

## Space Cooling

When premise air temperature rises above the set point, the dehumidifier control system issues a call for Space Cooling Mode and engages space cooler (Chilled water coil with valve) by sending space cooling signal, respective to space cooler control type - on/off or staged (multiple on/off valves).

## Interface and Communication

### Touch Display Operator Panel

The Touch Display Operator Panel (OP), shown on Pic. F.1, is used as a main interface between the dehumidifier and operator. The same OP can be located in the dehumidifier main electric panel (default; used as a local OP) or installed remotely from the dehumidifier

- **NOTE:** length of CAT5 or CAT6 cable, between remote OP and the dehumidifier MUST NOT exceed 1000'!

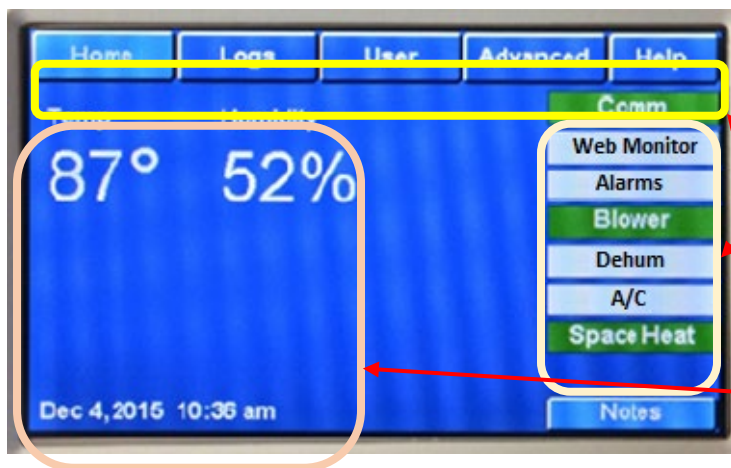

Touch Display OP allows to:

- Access Touch Display **Menus**
- View dehumidifier current operational statuses (Touch Display Communication, Alarms, dehumidifier operational calls, etc.)
- View controlled parameters' values (premise air temperature, humidity and, if applicable, pool water

temperature) and current date and time.

Pic. F.1



### Touch Display Menus:

<b>Home</b>	Opens/returns to the home page
<b>Logs</b>	Access to dehumidifier logs and log-related features ( <b>Alarms</b> , etc.)
<b>User</b>	Access to user settings ( <b>Setpoints</b> ) and commands ( <b>Stop/Restart</b> Dehumidifier, etc.)
<b>Advanced</b>	Access to advanced settings and features
<b>Help</b>	Context sensitive help presenting information related to the viewed page

### Most common/basic maintenance tasks performed using Touch Display OP

- ✓ **Adjust Setpoint** – in **User** menu: press the **User** button, then press the **Setpoints** button; select desired parameter (room air temperature etc.) and enter the desired value. Press the **Enter** button to confirm the entered value.
- ✓ **Stop/Restart Dehumidifier** — in **User** menu: press the **User** button, then press the **System Restart** button;
  - To stop and restart dehumidifier, press the **System Restart** button
  - To reboot Touch Display OP, press the **Restart Display** button
- ✓ **Review Alarm records** — done via the **Logs** menu: press the **Logs** button, then press the **Alarm Log** button.
- ✓ **Unlock device/dehumidifier, stopped and currently locked out on the alarm** — done via **Logs** menu: press the **Logs** button, then press the **Current Alarms** button; press the **Clear** button next to the respective alarm (the alarm that's locked out the device or entire dehumidifier).

For detailed information on TouchDisplay OP refer to **DASV Touch Display Manual**, provided with the dehumidifier (or contact factory to obtain a copy).

### Alarms

If the dehumidifier control system detects abnormal or unsafe for further operation situation, it issues **Alarm** (notification of such situation accompanied by respective component or entire dehumidifier stoppage and/or lockout) or **Alert** (notification of minor abnormal situation without any devices' stoppage or lockout).

All alarms and alerts are recorded and can be viewed/cleared via the Touch Display OP:

- ✓ Viewed: to facilitate troubleshooting and addressing abnormal situation
- ✓ Cleared: to unlock stopped device or entire dehumidifier and allow for further operation

The table F.1 below lists the basic alarms with their descriptions and recommended initial troubleshooting.

<b>Table F.1. Most Common Alarms/Alerts</b>		
<b>Alarm</b>	<b>Alarm Description</b>	<b>Check</b>
No Air	No air flow (air flow switch fault – <i>if air flow switch is installed</i> )	Check main blower operation and air flow switch
Blower OL	Main Blower overload/safety fault	Check main blower operation and its LED light blinking pattern.
Fire	Fire/smoke detector fault – <i>if detector is installed externally and connected to control board</i>	Check external fire/smoke detector/system
Freeze	Supply Air temperature is lower than Freezestat Setting (default: 45 F)	Check SA temperature readout, space heating system operation
Filter	<u>Alert</u> , indicating that filter change timer has lapsed – <i>if timer is activated</i>	Clear the Filter alarm and cancel filter scheduler if not in use.
VM	Voltage Monitor fault – power supply (phasing, voltage etc.) is outside of pre-set limits	Check Voltage Monitor info/status, incoming power (voltage)
Heat Recovery OL	Active when there is a heat recovery pump overload alarm	Check heat recovery pump operation

- ✓ Note that proper and regular maintenance (example: keeping air filters and air-side coils clean) should reduce the chances of abnormal operations, dehumidifier alarm-related stoppages and downtime.

 **CAUTION!** We recommend you have a qualified professional investigate and remedy all reoccurring alarm-related stoppages and lock-outs. Continuous dehumidifier restarting (clearing alarms) without addressing actual issues may result in equipment malfunction, premature wear, and failure.

For more details regarding alarms and alerts, refer to the **Alarms Description** information (available via Help feature in Touch Display OP); contact factory if needed.

## Remote Communication

Although dehumidifier is designed to operate as a self-controlled device (not requiring any external control), communication between the dehumidifier and external control and monitoring systems is possible.

## WebSentry

**WebSentry** is an online tool (also referred to as Web Monitor), that allows for remote communication to the dehumidifier for various purposes such as monitoring, data collection, parameters adjustment, and notifications. This feature is included with all dehumidifiers and is useful for maintenance teams and service providers (HVACR technicians).

To establish Web Monitor communication, the dehumidifier must communicate with the factory server via the Internet:

- Connect the dehumidifier to a local network switch, router or wireless AP device (providing connection to a local network):
  - o Plug an Ethernet cable into the sub-board Ethernet RJ-45 jack (sub-board, called Core Module, is located on the main control board in the main electric panel) – see Pic. F.2.
    - **Note:** separate RJ-45 jack (plastic, black) is mounted on the control board directly, for TouchDisplay connection. Make sure to use the proper jack (metal-surface one, located on the sub-board) for Web Monitor connection.
- Configure, as needed, local server and dehumidifier network settings.

### BMS (Building Management System)

Communication to BMS can also be supported, depending on the type of communication protocol said BMS utilizes.

The equipment control software supports most common of them

- different control software variation might be required to support different BMS communication protocols. Contact factory if necessary.

**BACnet** (Internet, IP). Communication is established via the Ethernet cable (same method as Web Monitor).

- ✓ BACnet and Web Monitor communication can be used simultaneously.

**LON** or **Modbus**. Communication requires external wiring between dehumidifier main control board and BMS terminal. Wiring schematic is normally indicated on wiring diagram (provided with dehumidifier).

- ✓ If dehumidifier is equipped with LON communication option, it's normally provided with pre-wired LonWorks Gateway for communication purposes.

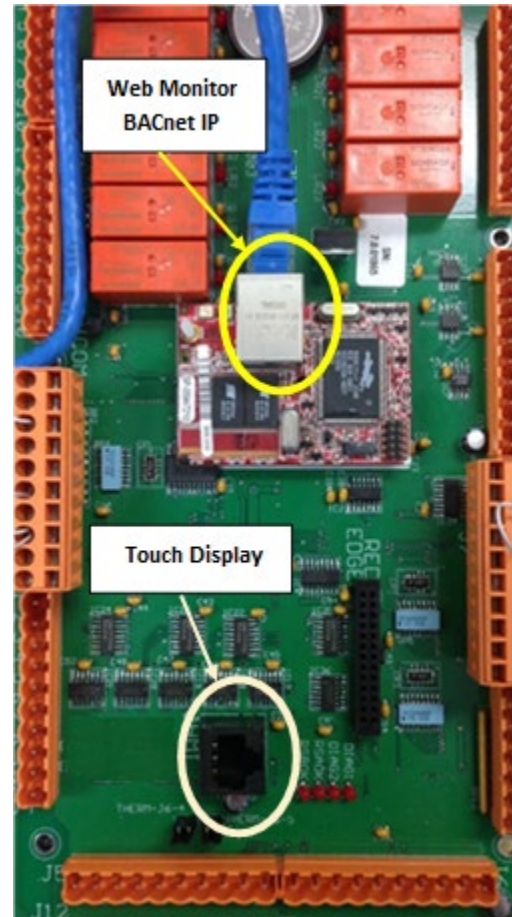

For more information about Web Monitor or BMS communication set up (connection, configuration, access, point cutsheets, etc.) – contact factory.

Pic. F.2

## Basic Maintenance

Although PoolPak equipment is built for minimal service downtime, periodic preventative maintenance is required to ensure maximum reliability, safety, and operating efficiency.

**⚠ WARNING!** To ensure equipment longevity and proper and efficient operation, the dehumidifier and its auxiliary systems and devices **must** be **maintained** properly and regularly. It is recommended to create a **facility-specific Routine Maintenance Program**. Failure to maintain the equipment properly and regularly could result in personal injury, equipment damage or malfunction and will void the equipment warranty.

## Maintenance and Safety

Only qualified/properly trained personnel should attempt to perform respective maintenance tasks.

- When it is necessary to work with live electrical components, have a licensed electrician or other qualified professional perform the required task.
- **Be properly trained and equipped.** Some maintenance tasks may involve usage of power tools, chemicals, etc. Refer to such tools and materials data (manuals, MSDS, etc.). Responsible maintenance personnel should be:
  - Properly trained to handle such tools and materials safely
  - Equipped with proper personal protective equipment
- **Turn the power off.** Before performing any maintenance, disconnect all electrical power, including remote disconnect, and discharge all energy storing devices (VFDs, etc.) before servicing. Follow proper lockout procedures to ensure that power cannot be accidentally restored. Failure to follow provided safety warnings and labels could result in serious injury or death.
- **Be aware of potential hazards.** The equipment contains moving mechanical parts and surfaces with high temperatures. Before entering the dehumidifier and/or performing any equipment maintenance work, make sure that all moving parts are stopped, and it is safe to perform required task.

## Maintenance Key Points

Here are some basic/key maintenance considerations, pertinent to all dehumidifiers and their auxiliary systems:

- Dehumidifier in mechanical room. **No chemicals** should be stored **in the same mechanical room** where the dehumidifier is installed. Chemical fumes/off-gas can cause premature deterioration of the equipment.
  - Store chemicals in a separate, well-ventilated room.
- Access to the Equipment. Ensure that the **equipment is accessible** (minimum clearances are maintained): approaches to the dehumidifier are not restricted/limited with materials in mechanical room (indoor installed) or with snow (outdoor installed dehumidifiers, OACC and OAFc).
- "MUST DO" maintenance task. Although all other maintenance tasks are as important, these two maintenance tasks are the most common and most helpful:
  - Maintain **clean air filters** (return, outdoor air filters, etc.). Make sure to replace dirty filters regularly.
  - Maintain **clean air-side coils**. Make sure to clean coils regularly.
- Pool Water Chemistry. Incorrect pool water chemistry (improper pH level or high concentration of chlorine, sea salt or other corrosive additives etc.) can result in equipment premature wear or malfunction (let alone poor air quality in the pool and potential health issues) and will void the equipment warranty. Refer to pool water quality standards; contact factory as needed.

## Routine Maintenance Program

Creating facility-specific routine maintenance program and following it is vital to equipment longevity and efficient operation.

The suggested general maintenance operations and their frequency/intervals, listed in the table M-1 below, can be used to create such a program. For more detailed maintenance recommendations related to specific components, refer to the respective component manufacturer's manual.

<b>Table M.1. Recommended Maintenance Tasks and Intervals</b>	
<b>Interval</b>	<b>Maintenance Task</b>
Weekly	Observe the equipment for any changes in running conditions and unusual noise
Quarterly	Clean or replace air filters if clogged or dirty
	Verify that all set-points are correctly programmed as specified by the facility operator
Semi-Annually	Inspect and clean the drain pan(s)
	Tighten electrical connections, if required
	Inspect all airside coils for dirt, cobweb build-up, etc.; clean as needed
	Check that the P-trap is primed (filled with water). It is good practice to pour some water into the drain pan to ensure that the P-trap is primed and operational
	Check the outdoor air louvres and dampers for accumulation of dust and clean as required
	Inspect the equipment's cabinet for corrosion. If any damage is found, clean and repaint the affected surface with a rust-resistant primer
Annually	Clean the fan wheel(s)
	Check dampers operation (linkage/actuator is not loose, damper opens/closes properly etc.)
	Inspect electrical components, wiring and insulation
	Rotate the fan wheel(s) and check for obstructions and rubbing
	Check gasket condition on all doors to ensure an airtight seal
	Check bolts on motor mounts, dehumidifier bases and coils and tighten if required

## Specific Components Maintenance

Actual maintenance plan may vary from installation to installation, yet there are several key components from maintenance prospective.

If needed, contact respective component manufacturer for additional maintenance information.

### Filters

- Ensure air filters are clean. Dirty air filters will negatively affect dehumidifier performance and lifetime
- Frequency of filters replacement will vary based on air quality, dehumidifier usage, facility type, etc. Make sure to replace filters regularly
- Replace with filters of equivalent size and rating – refer to dehumidifier details (compartment stickers, etc.)

### Insulation

Inspect dehumidifier insulation, exposed to airstream for microbial growth (i.e., mold). If there is evidence of microbial growth on the interior insulation, the insulation should be removed and replaced prior to operating the dehumidifier.

### Air-Side Coils

- **Warning: Hazardous chemicals!** Cleaning agents can be highly acidic or alkaline. Handle all chemicals carefully and use appropriate personal protective equipment (PPE). Refer to the cleaning agent manufacturer's Materials Safety Data Sheet (MSDS) for safety and handling information. Failure to follow all safety instructions could result in serious injury or death.
- **Warning: Hazardous pressures!** Coils must not be cleaned using a solution over 150 °F. Failure to follow these safety precautions could result in coil bursting, which could result in serious injury or death.

### To clean the coil

- Disconnect all electrical power to the equipment
- Use a soft brush to remove loose debris from the coil
- Mix a high-quality coil cleaning detergent with water according to the manufacturer's instructions
- Clean coil according to suggested instructions
- Thoroughly rinse both sides of the coil and the drain pan with, clean water
- Straighten any coil fins that have been bent during the cleaning process
- Confirm the drain line is clear
- Replace all panels and parts and restore electrical power to the equipment

## Pools – Equipment Warranty

### General Policy

All PoolPak service and warranty work is managed exclusively by Dehumidified Air Services (DASV). All warranties apply to the original equipment owner and are not transferable. All warranty inquiries should be made to Dehumidified Air Services.

#### Dehumidified Air Services:

Phone: 1-833-327-7665      Email: [Warranty@DehumidifiedAirServices.com](mailto:Warranty@DehumidifiedAirServices.com)

PoolPak warrants as set forth and for the time periods shown below that it will provide through either a DASV Service Technician or an authorized service organization specified and approved by DASV, a new or rebuilt part to replace a factory installed part which has failed because of defect in workmanship or material.

**NOTE: EVERY REQUEST RELATED TO WARRANTY OF ANY NATURE AS DESCRIBED BELOW MUST BE OFFICIALLY AUTHORIZED AND DOCUMENTED IN ADVANCE BY DASV TO QUALIFY FOR WARRANTY COVERAGE.**

### Warranty Void Unless Registered

All Warranties are void unless the start-up of the equipment is approved by a DASV service technician. Upon completion of the start-up, a “Warranty Registration Certificate” will be issued, along with the Start-Up Report, which activates the Warranty Period of the equipment. The Warranty Period will commence either upon completion of start-up registration of the equipment or 6 months from factory ship date, whichever comes first.

### Initial 90-Day Comprehensive Warranty

During the first 90 days from initial start-up, all parts and repairs related to factory defects or replacement parts are covered by the PoolPak manufacturer warranty. All parts and labor requirements will either be handled by DASV technicians directly or managed and approved in advance by DASV through DASV authorized technicians.

### Internet Connected, Conditional One Year Repair Warranty

If and only if the equipment is connected to the internet from the date of the warranty activation, a Repair Warranty will be provided for an additional 9 months subsequent to the initial 90-Day Comprehensive Warranty for a total of 12 months of parts and labor warranty coverage. The unit must be connected and communicating to PoolPak WebSentry for the entire term from start-up in order to qualify.

If qualified, PoolPak will provide or pay for the required part and direct labor only, related to the part replacement. Only the labor required to replace the defective part is under warranty for this 9-month extension. Travel time, diagnostic time, per diems, truck charges, shipping charges etc. are not covered under this Conditional Repair Warranty.

### Two-Year Parts Warranty

If any factory installed part supplied by PoolPak fails because of a defect in workmanship or material, prior to the completion of the 24<sup>th</sup> month from date of completion of the warranty activation, PoolPak will provide a new or rebuilt part F.O.B. our factory. No labour reimbursement will be made for expenses incurred in replacing the part except as set in the *Initial 90-day Comprehensive or Internet Connected Conditional One-Year Repair Warranty*.



PoolPak reserves the right to have the defective part returned to the factory in order to determine the warranty applicability. Parts shipping and handling costs (to and from the factory) are not covered outside of the *Initial 90-day Warranty*.

## Replacement Part Warranty

If a replacement part provided by PoolPak under this warranty fails due to a material defect prior to the end of the Two-Year Parts Warranty (or the end of the extended warranty period if applicable), whichever comes first, PoolPak will provide a new or rebuilt part F.O.B. factory.

## Applicability

This warranty is applicable only to products that are purchased and installed in the United States and Canada. This warranty is NOT applicable to:

1. Products that have become defective or damaged as a result of non-DASV or unauthorized service work, poor maintenance, faulty electrical supply, act of God, or any other circumstances outside of the specified care, maintenance or operation of the equipment including:
  - Components that have been relocated from their original placement during manufacturing.
  - Any portion of the system not supplied by PoolPak.
  - Components on which the model and/or serial number plates have been removed or defaced.
  - Components which have become defective or damaged as a result of unauthorized opening of the refrigeration circuit, improper wiring, electrical supply characteristics, poor maintenance, accidents, transportation, misuse, abuse, fire, flood, alteration and/or misapplication of the product.
  - Products not installed, operated and maintained as per the PoolPak Operating and Maintenance Manual.
  - Products on which payment is in default.
2. Parts that wear out due to normal usage such as; air filters, fuses and sensors are not covered by this warranty.

NOTE: Refrigerant lost during the *Initial 90-day Comprehensive or Internet Connected Conditional One-Year Repair Warranty* will be reimbursed in accordance to the current market price of refrigerant at the time of repair and upon discretion of Customer Support team. PoolPak will not be responsible for refrigerant lost from the system due to improperly installed contractor piping to the remote outdoor air-cooled condenser.

## Limitations

1. DASV is a Manufacturer Service organization, not a first-response or urgent response local service company. As such, we highly recommend that equipment owners have a relationship with their own qualified first response service organization or one recommended by DASV.

DASV hours of operation are from 8:00 AM to 6:00 PM Monday through Friday, unless otherwise agreed to under a separate agreement.

Parts replacement can be subject to availability. We highly recommend for mission-critical applications that owners purchase and maintain a local stock of critical

components in case immediate replacement be required. If for any reason one of those components is replaced under applicable warranty conditions, PoolPak will reimburse the original cost of any component used under terms of Warranty.

NOTE: PoolPak expressly disclaims any liability for parts replacement delays due to parts unavailability or shipping delays.

2. This warranty is given in lieu of all other warranties. Anything in the warranty notwithstanding, any implied warranties of fitness for particular purpose and merchantability shall be limited to the duration of the warranties described above. PoolPak expressly disclaims and excludes any liability for consequential or incidental damage for breach of any express or implied warranty.

Where a jurisdiction does not allow limitations or exclusions in a warranty, the foregoing limitations and exclusions shall not apply to the extent of the legislation, however, in such case the balance of the above warranty shall remain in full force and effect.

This warranty gives specific legal rights. Other rights may vary according to local legislation.

## **Force Majeure**

PoolPak will not be liable for delay or failure to provide warranty service due to government restrictions or restraints, war, strikes, material shortages, acts of God or other causes beyond PoolPak control.

## **Optional Extended Warranties**

If purchased prior to shipment and documented with a registered extended warranty statement certificate, PoolPak will provide replacement components within the specified period of the extended warranties. Extended warranties commence either upon completion of start-up registration of the equipment or 6 months from factory ship date, whichever comes first, and cover parts replacement only for parts that fail as a result of manufacturing defect. The failed parts must be returned to the factory with transportation prepaid by the customer as a condition of these warranties. Optional extended warranties are for parts only and subject to all the terms of the Two-Year Parts Warranty.

### **1. Optional Five-Year Compressor Warranty**

Subject to the terms above, PoolPak will provide a replacement compressor for up to 60 months from the date of the warranty activation.

### **2. Optional Five-Year Dehumidifier Coil Warranty**

Subject to the terms above, PoolPak will provide a replacement coil for up to 60 months from the date of the warranty activation. Extended coil warranties are for parts of the dehumidifier only and does not cover parts of dry cooler or OACC coils.

### **3. Optional Ten Year Dehumidifier Coil Warranty**

Subject to the terms above, PoolPak will provide a replacement coil for up to 120 months from the date of the warranty activation. Extended coil warranties are for parts of the dehumidifier only and does not cover parts of dry cooler or OACC coils.

#### **4. Optional Five-Year Driveline Warranty**

Subject to the terms above, PoolPak will provide driveline replacement parts for up to 60 months from the date of the warranty activation.

Driveline Components Include:

- Supply fan motor
- Exhaust fan motor (including Min Exhaust and Purge Exhaust motors)
- Heat recovery loop pump
- Compressor glycol/water pump
- Dry cooler/outdoor condenser fan(s)
- Dry cooler pump(s)