



PCP SERIES DEHUMIDIFIERS

Indoor

OPERATION AND MAINTENANCE MANUAL

PoolPak.com

Table of Content

General Information	4
• Operating Safety	4
• Reference and Additional Information	5
○ Contact Us	5
• Basic Information	6
○ Dehumidifier View and Options – S Cab	6
○ Dehumidifier View and Options – RV and RH Cabs	8
○ Dehumidifier View and Options – SLB Cab	12
○ Pool Water Heating Option – Bonding	15
○ Air Conditioning Option – Outdoor Air Condensers	16
○ Air Conditioning Option – Fluid Coolers	17
○ Equipment Specific Data	19
Layout and Components	20
• Dehumidifier Main Components – S and SLB Cab	20
• Dehumidifier Main Components – RV and RH Cabs	22
• Control System	25
• Outdoor Air Condensers and Fluid Coolers Layout and Components	28
Sequence of Operation	30
• Set Points	30
• Ventilation	31
• Space Heating	31
• Air Conditioning, Dehumidification and Pool Heating	31
○ Compressor(s)	31
Interface and Communication	32
• Touch Display Operator Panel	32
○ Alarms	33
• Remote Communication	34
Basic Maintenance	35
• Maintenance and Safety	35
• Maintenance Key Points	35
• Routine Maintenance Program	36
• Specific Components Maintenance	37
Warranty	39

General Information

This manual provides basic information about the applicable dehumidifier and its operation.

Important information regarding installation, maintenance, and start up as well as additional and auxiliary systems and devices (outdoor condenser, communication interfaces, etc.) is normally provided with the dehumidifier and can also be obtained at factory (see **Contact Us** below).

Operating Safety (Warnings, Cautions, and Notes)

FOR YOUR SAFETY: READ BEFORE PERFORMING ANY OPERATIONS, MAINTENANCE OR SERVICE TASKS!



Only qualified technicians should install, operate, maintain or service mechanical equipment including current dehumidification system.

Make sure to read this manual before performing any tasks to familiarize yourself with the equipment as well as with any potential hazards. Always exercise caution!



Beware of electrical power and high electrical voltage!

- Follow proper safety procedures – lockout, tagout, and other respective procedures
- Failure to follow safety procedures can result in serious injury or death



Beware of moving parts and hot surfaces!

- Make sure to stop all moving parts (fans, blowers, etc.) before accessing the equipment's internal space
- Be aware of hot surfaces (hot refrigeration, space heating pipes, coils, heaters, etc.)



Beware of high pressures and chemicals!

- Dehumidifiers, equipped with compressors, contain refrigerant under high pressure; oil is also contained in the compressor and refrigeration circuit(s)
- Some dehumidifiers may also contain other liquids such as glycol mixtures and pool water

The following warnings, cautions, and notes appear throughout this manual and referenced documentation whenever special care must be taken to avoid potential hazards that could result in equipment malfunction or damage, personal injury, or death.



WARNING

Indicates a potentially hazardous situation which could result in serious injury or death if handled improperly.



CAUTION

Indicates a potentially hazardous situation which could result in moderate injury or equipment damage if handled improperly.

Note

Indicates a situation that could result in equipment damage or improper/ineffective operation if handled improperly.

Reference and Additional Information

For safe, efficient and problem-free operation, it is critical to handle the dehumidifier (as well as related systems and components) properly at each step - from receiving and storage to installation and start up. Relevant information can be found in the respective documents (like **Installation Manual**) provided with the dehumidifier.

This manual and other related documents could be obtained from the manufacturer (see **Contact Us** below).

Attention: Installation and Service Contractors



WARNING! Any work (installation, start up, service, maintenance, repair, etc.) on any mechanical equipment (dehumidifier, outdoor condenser, fluid cooler, etc.) must be performed in accordance with respective manufacturer's recommendations as well as submittal documentation, local Codes and Regulations, and appropriate field practices. Failure to do so could result in personal injury, equipment damage or malfunction, and will void equipment warranty. Only qualified and properly trained individuals should perform tasks on this equipment.

Attention: Maintenance Team



CAUTION. To ensure equipment longevity and proper and efficient operation, the dehumidifier and its auxiliary systems and devices (outdoor condenser, fluid cooler, etc.) should be maintained properly and regularly. Failure to do so could negatively affect premise comfort levels and people's health. It could also lead to equipment damage, malfunction, premature tear and ware and may void equipment warranty.

Contact Us

PoolPak
3491 Industrial Drive
York, PA 17403
USA

PoolPak.com

1-833-DAS-POOL (327-7665)

Schedule / Modify a Start-up:

Scheduling@DehumidifiedAirServices.com

Inquire about Warranty:

Warranty@DehumidifiedAirServices.com

Order Parts:

Parts@DehumidifiedAirServices.com

All Other Product Support:

Support@DehumidifiedAirServices.com

Basic Information

Dehumidifier View and Options – S Cab

Standard PCP800 and PCP1200 dehumidifier's general views and options * are shown on Pic.C.1.

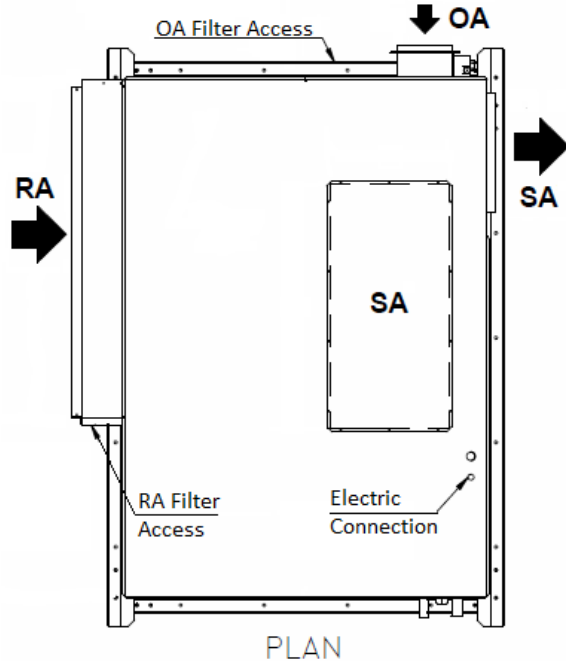

Options:

- Return Air (RA) ductwork connection - horizontal.
- Supply Air (SA) ductwork connection options – top, bottom, horizontal*.
- Outdoor Air (OA) intake - horizontal*.

Piping Connections	
①	Condensate Drain
②	AC – Air-Cooled (refrigeration)
③	AC – Water-Cooled (water/glycol)
④	Pool Heating Water
⑤	Space Heating Hot Water

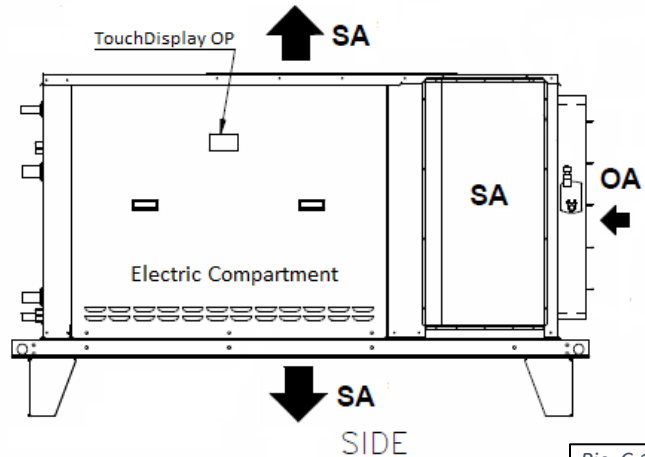
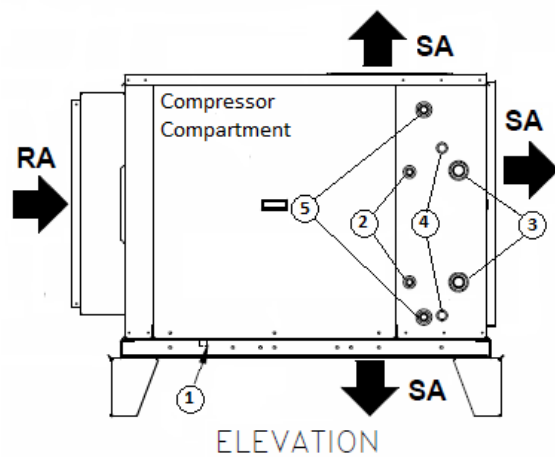

Pic. C.1

Dehumidifier Options:

- Indoor, single-compressor dehumidifiers 2 and 3 tons' capacity (apprx.) - models PCP800 and PCP1200 *.
 - Two-compressor dehumidifier option (see **Dehumidifier Optional Arrangement** below for details):
 - 4 and 6 ton cooling capacity (apprx.) - models PCP808 and PCP1212.
- Airflow and ductwork connection options* (Return Air, Supply Air, Outdoor Air) - as shown on Pic. C.1.
- Optional **Pool Water Heating** **.
- Optional **Space Heating** - hot water coil, electric or gas heater ***.
- **Air Conditioning (AC)*** – external water cooling, outdoor condenser or fluid cooler.

* All available options (tonnage, ductwork connections, AC options etc.) are shown. Refer to the submittal and other relevant documentation for your equipment options, dimensions etc.

** The pool water heating option relies on compressor-created excess heat and is used as an additional heating source. It does not eliminate the need for a main pool water heater.

*** For specific details on space heating (hot water, gas, electric) option, refer to the submittal and other documentation:

- **Gas-fired duct heater** can be provided for field installation (to be fitted in the supply air ductwork).
- **Electric heater** or **hot water coil**, depending on capacity, model, size, etc., can be installed externally (mounted on the top of SA opening or fitted in the supply air ductwork) or internally. Refer to your dehumidifier's submittal documentation.

Attention! Equipment Clearances and Dimensions!



CAUTION! For equipment proper operation, maintenance and service, respective clearances should be maintained. Generally, 30" clearances to the equipment must be kept for the maintenance and service purposes. For the specific required clearances information, as well as dehumidifier overall dimensions, distances to pipe connections, duct connections etc., refer to the submittal documentation.

Dehumidifier External Systems Connection – S Cab

Pic. C.1 shows provisions for external systems connections, including ductwork, electric power and control wires and various piping connections.

CAUTION! Current manual shows general/default connections' location. For details regarding specific dehumidifier's connections (actual location, piping sizes and position dimensions, circuit type and flow direction etc.), refer to the dehumidifier's submittal documentation as well as dehumidifier's labels and stickers.

- Except for the condensate, all other piping systems are optional and may not be present in each dehumidifier.

NOTE. Dehumidifier **MUST** be equipped with a **P-trap** at the **condensate connection** for proper operation! If dehumidifier is requested/provided from the factory without P-trap, one **MUST** be installed on site prior to dehumidifier being commissioned. Refer to the dehumidifier stickers and **Installation Manual** for details.

- **Air Conditioning (AC) Connection.** Normally, the dehumidifier has only one AC option – air-cooled (requiring connection to the outdoor air condenser) or water-cooled (requiring connection to the fluid cooler or other external water-cooled system such as geothermal, cooling tower, etc.). Therefore, only one of these options present with the actual dehumidifier.
- **Gas line.** If the dehumidifier is equipped with a gas heater for space heating purposes, the **gas** line connection is to be brought to the gas heater directly.



WARNING! Gas Line. The gas line must be installed in accordance with respective device documentation and local codes and regulations.

Dehumidifier View and Options – RV and RH Cabs

Standard PCP1400 – PCP2600 dehumidifiers come in vertical (Pic.C.1-A) or horizontal (Pic.C.1-B) composition:

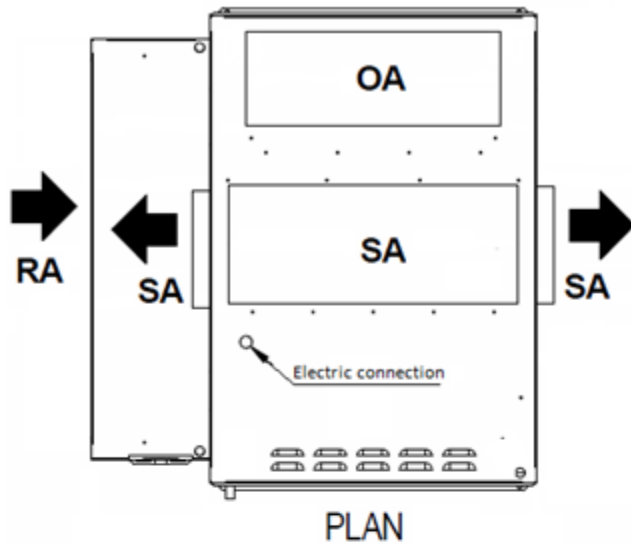

Vertical Composition

- Return Air (RA) ductwork connection - horizontal.
- Supply Air (SA) ductwork connection options – top, horizontal (left or right).
- Outdoor Air (OA) intake - top

Piping Connections	
①	Condensate Drain
②	AC – Air-Cooled (refrigeration)
③	AC – Water-Cooled (water/glycol)
④	Pool Heating Water
⑤	Space Heating Hot Water

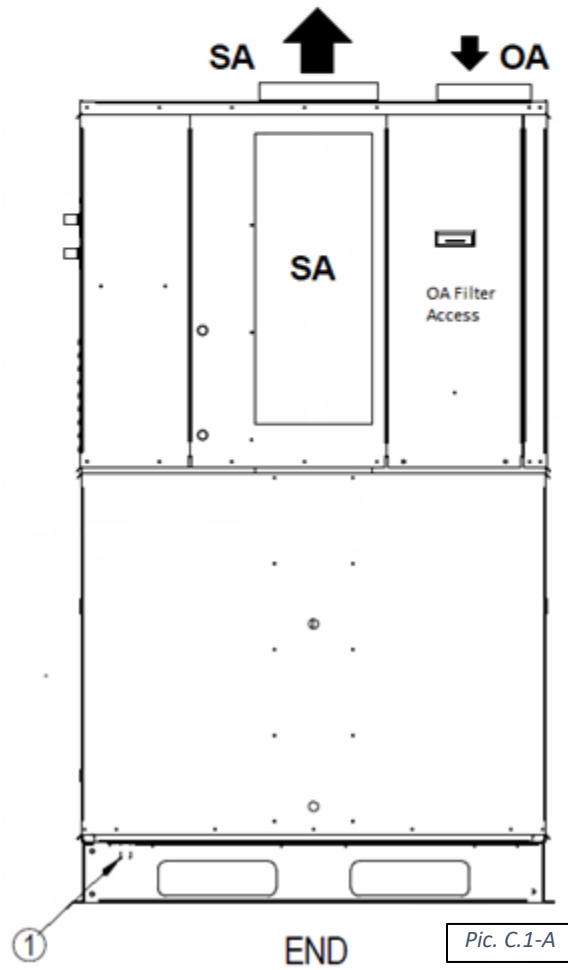
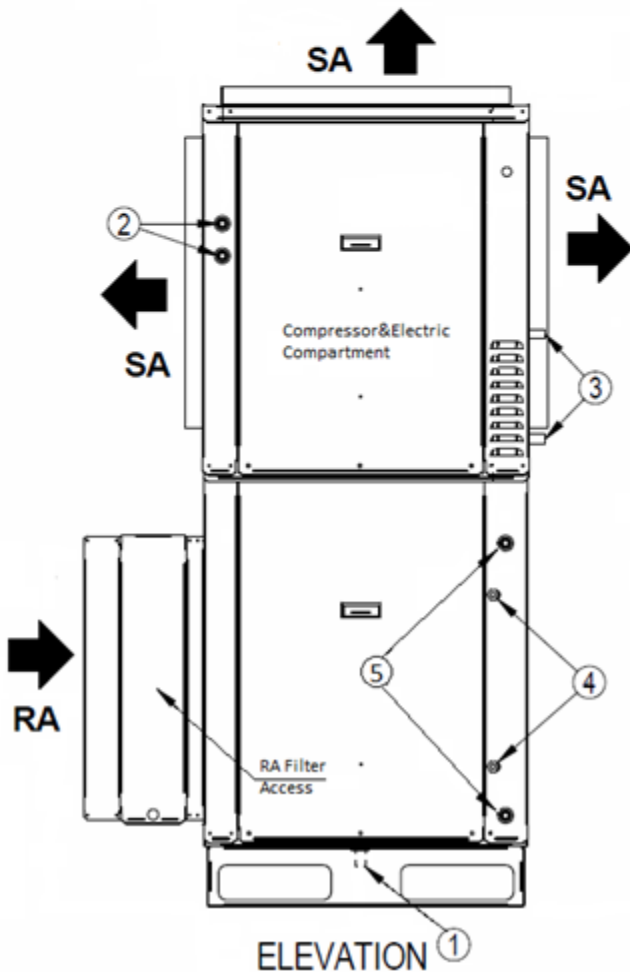

Pic. C.1-A

Horizontal Composition

- Return Air (RA) ductwork connection - horizontal.
- Supply Air (SA) ductwork connection options – top, bottom, horizontal (straight).
- Outdoor Air (OA) intake ductwork connection options – top, horizontal.

Piping Connections	
①	Condensate Drain
②	AC – Air-Cooled (refrigeration)
③	AC – Water-Cooled (water/glycol)
④	Pool Heating Water
⑤	Space Heating Hot Water

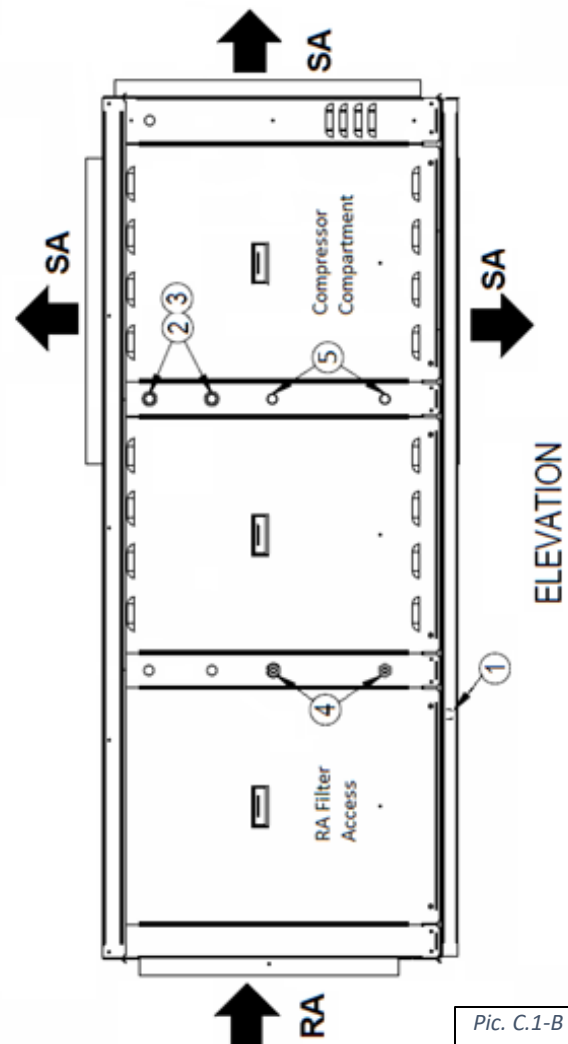
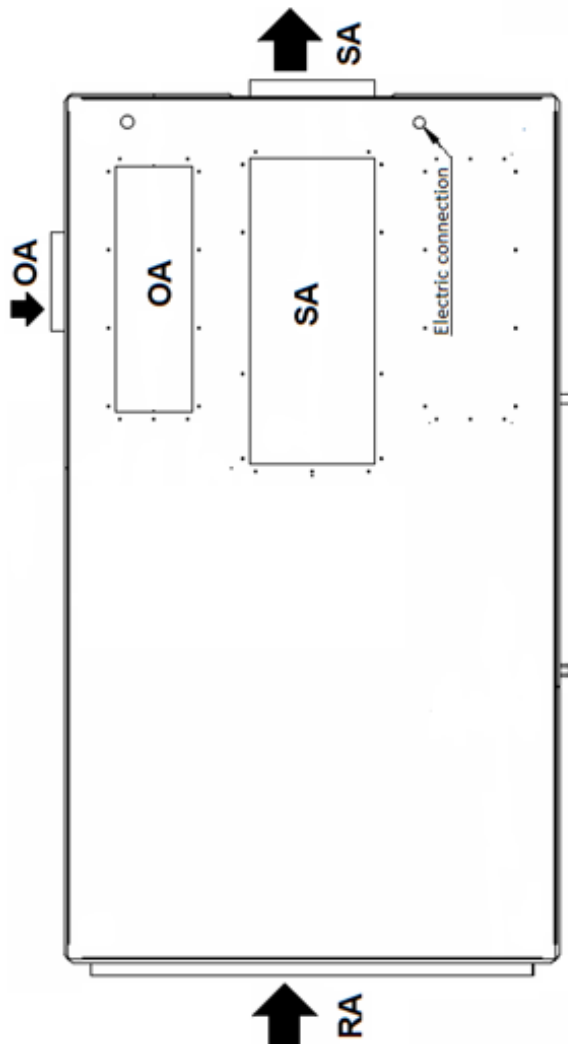
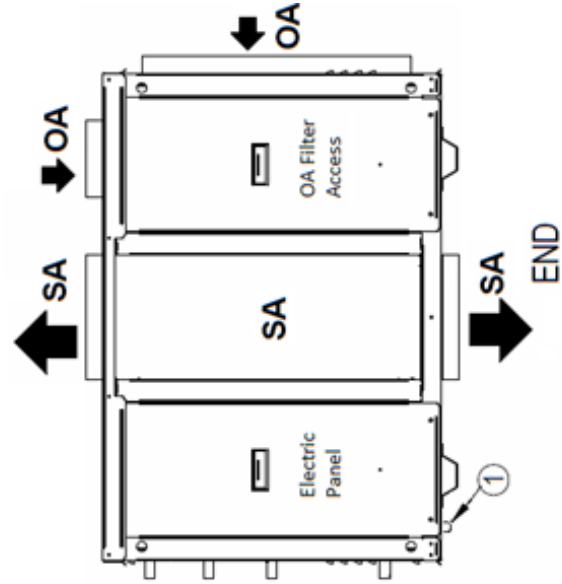

Pic. C.1-B

Dehumidifier Options (applicable to both, vertical and horizontal, configurations):

- Indoor, single-compressor dehumidifiers, 4 to 7 ton cooling capacity (apprx.) - models PCP1400 to PCP2600 *.
 - Two-compressor dehumidifier option (see **Dehumidifier Optional Arrangement** below for details):
 - 8 to 14 ton cooling capacity (apprx.) - models PCP1414 to PCP2626
- Airflow and ductwork connection options* (Return, Supply and Outdoor Air) - see Pic. C.1-A and C.1 – B.
- Optional **Pool Water Heating** **.
- Optional **Space Heating** - hot water coil, electric or gas heater ***.
- **Air Conditioning (AC)*** – external water cooling, outdoor condenser or fluid cooler.

* All available options (tonnage, ductwork connections, AC options etc.) are shown. Refer to the submittal and other relevant documentation for your equipment options, dimensions etc.

** The pool water heating option relies on compressor-created excess heat and is used as an additional heating source. It does not eliminate the need for a main pool water heater.

*** For specific details on space heating (hot water, gas, electric) option, refer to the submittal and other documentation:

- **Gas-fired duct heater** can be provided for field installation (to be fitted in the supply air ductwork).
- **Electric heater**, depending on various factors (capacity, model, size, etc.), can be installed externally (mounted on the top of SA opening) or internally. Refer to your dehumidifier's submittal documentation.

Attention! Equipment Clearances and Dimensions!



CAUTION! For equipment proper operation, maintenance and service, respective clearances should be maintained. Generally, 30" clearances to the equipment must be kept for the maintenance and service purposes. For the specific required clearances information, as well as dehumidifier overall dimensions, distances to pipe connections, duct connections etc., refer to the submittal documentation.

Dehumidifier External Systems Connection – RH and RV cabs

Pic. C.1 – A and B show provisions for external systems connections, including ductwork, electric power and control wires and various piping connections.

CAUTION! Current manual shows general/default connections' location. For details regarding specific dehumidifier's connections (actual location, piping sizes and position dimensions, circuit type and flow direction etc.), refer to the dehumidifier's submittal documentation as well as dehumidifier's labels and stickers.

- Except for the condensate, all other piping systems are optional and may not be present in each dehumidifier.

NOTE. Dehumidifier **MUST** be equipped with a **P-trap** at the **condensate connection** for proper operation! If dehumidifier is requested/provided from the factory without P-trap, one **MUST** be installed on site prior to dehumidifier being commissioned. Refer to the dehumidifier stickers and **Installation Manual** for details.

- **Air Conditioning (AC) Connection.** Normally, the dehumidifier has only one AC option – air-cooled (requiring connection to the outdoor air condenser) or water-cooled (requiring connection to the fluid cooler or other external water-cooled system such as geothermal, cooling tower, etc.). Therefore, only one of these options present with the actual dehumidifier.
- **Gas line.** If the dehumidifier is equipped with a gas heater for space heating purposes, the **gas** line connection is to be brought to the gas heater directly.



WARNING! Gas Line. The gas line must be installed in accordance with respective device documentation and local codes and regulations.

Dehumidifier Optional Arrangement – RH and RV Cabs

Mirrored Arrangement

Both, horizontal and vertical, dehumidifier could have standard and mirrored cabinet arrangement (see Pic.C.2).

Note, that all options and details, described above, apply to both, standard and mirrored arrangement.

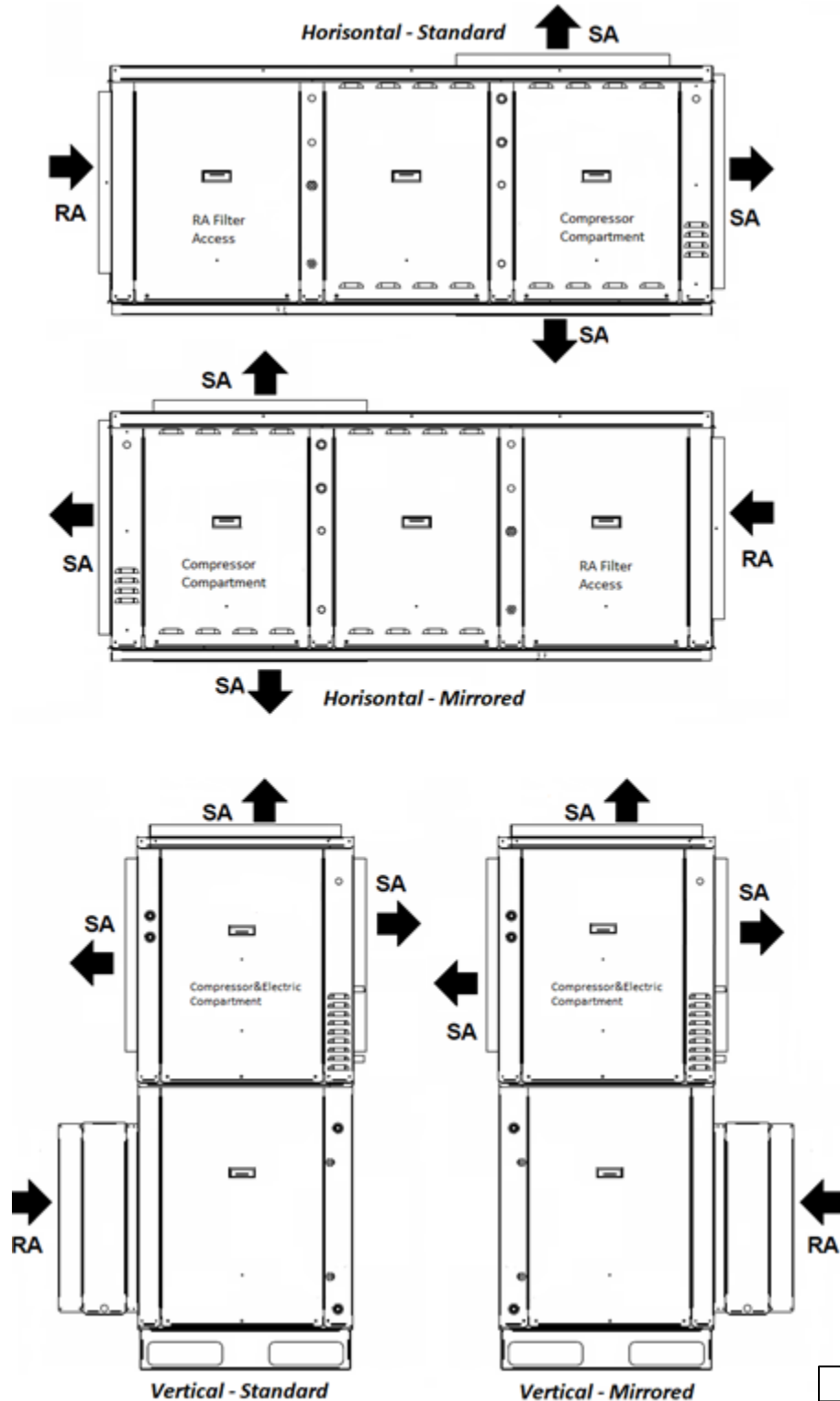

Pic. C.2

Dehumidifier View and Options – SLB cab

Standard PCP3000 – PCP5000 dehumidifiers views and options are shown in Pic.C.1 below.

- Return Air (**RA**) ductwork connection - horizontal.
- Supply Air (**SA**) ductwork connection options – top, bottom, horizontal side (supply end).
- Outdoor Air (**OA**) intake ductwork connection option – left side.

Piping Connections	
①	Condensate Drain
②	AC – Air-Cooled (refrigeration)
③	AC – Water-Cooled (water/glycol)
④	Pool Heating Water
⑤	Space Heating Hot Water
⑥	Electrical connection

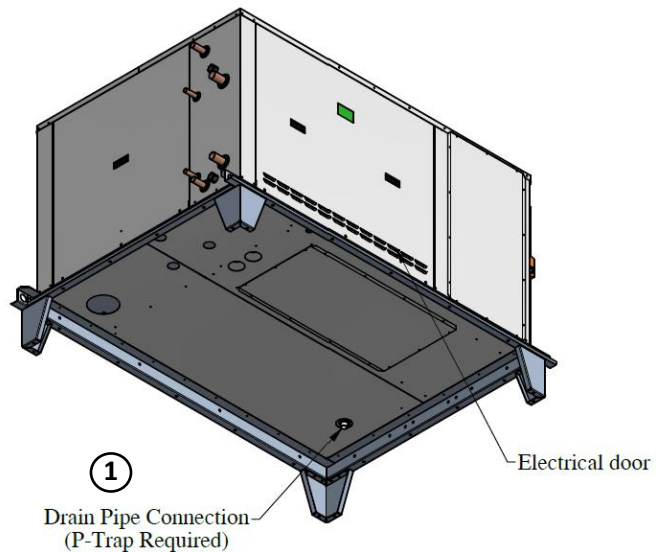
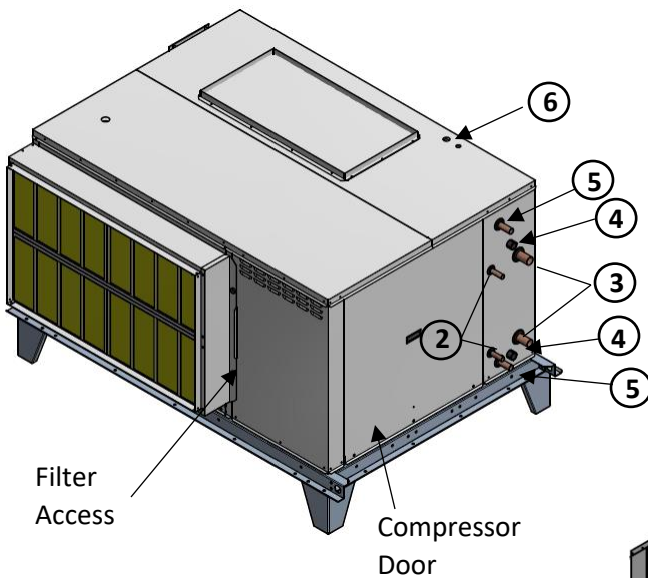
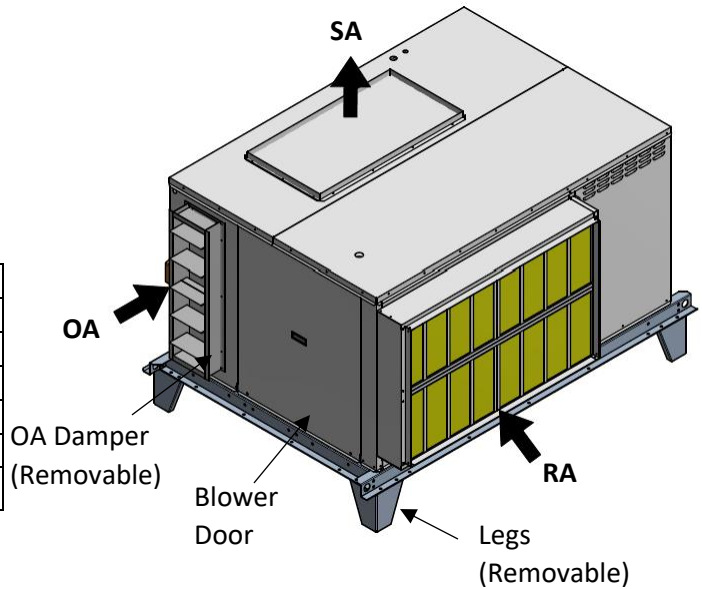

Pic. C.1-A

Dehumidifier Options (applicable to both, vertical and horizontal, configurations):

- Indoor, single-compressor dehumidifiers, 8 to 16 tons' capacity (apprx.) - models PCP3000 to PCP5000 *.
 - Two-compressor dehumidifier option (16 to 32 tons' capacity (apprx.) - models PCP3030 to PCP5050 - see **Dehumidifier Optional Arrangement** below.
- Airflow and ductwork connection options (Return Air (**RA**), Supply Air (**SA**) Outdoor Air (**OA**)) * - as shown on Pic. C.1-A.
- Optional **Pool Water Heating** **.
- Optional **Space Heating** - hot water coil, electric or gas heater ***.
- **Air Conditioning (AC)*** – external water cooling, outdoor condenser or fluid cooler.

* All available options (tonnage, ductwork connections, AC options etc.) are shown. Refer to the submittal and other relevant documentation for your dehumidifier's options.

** The pool water heating option relies on compressor-created excess heat and is used as an additional heating source. It does not eliminate the need for a main pool water heater.

*** For specific details on space heating (hot water, gas, electric) option, refer to the submittal and other documentation:

- **Gas-fired duct heater** can be provided for field installation (to be fitted in the supply air ductwork).
- **Electric heater or hot water coil**, depending on capacity, model, size, etc., can be installed externally (mounted on the top of SA opening or fitted in the supply air ductwork) or internally. Refer to your dehumidifier's submittal documentation.

Attention! Equipment Clearances and Dimensions!



CAUTION! For equipment proper operation, maintenance and service, respective clearances should be maintained. Generally, 30" clearances to the equipment must be kept for the maintenance and service purposes. For the specific required clearances information, as well as dehumidifier overall dimensions, distances to pipe connections, duct connections etc., refer to the submittal documentation.

Dehumidifier External Systems Connection

Pic. C.1 – A shows provisions for external systems connections, including ductwork, electric power and control wires and various piping connections.

CAUTION! Current manual shows general/default connections' location. For details regarding specific dehumidifier's connections (actual location, piping sizes and position dimensions, circuit type and flow direction etc.), refer to the dehumidifier's submittal documentation as well as dehumidifier's labels and stickers.

- Except for the condensate, all other piping systems are optional and may not be present in each dehumidifier.

NOTE. Dehumidifier **MUST** be equipped with a **P-trap** at the **condensate connection** for proper operation! If dehumidifier is requested/provided from the factory without P-trap, one **MUST** be installed on site prior to dehumidifier being commissioned. Refer to the dehumidifier stickers and **Installation Manual** for details.

- **Air Conditioning (AC) Connection.** Normally, the dehumidifier has only one AC option – air-cooled (requiring connection to the outdoor air condenser) or water-cooled (requiring connection to the fluid cooler or other external water-cooled system such as geothermal, cooling tower, etc.). Therefore, only one of these options present with the actual dehumidifier.

- **Gas line.** If the dehumidifier is equipped with a gas heater for space heating purposes, the **gas** line connection is to be brought to the gas heater directly.

⚠️ WARNING! Gas Line. The gas line must be installed in accordance with respective device documentation and local codes and regulations.

Dehumidifier Optional Arrangement.

Two-Compressor Arrangement

Standard PCP series dehumidifier has one compressor, however two-compressor arrangement is available also. Note, that all options and details, provided above, apply to both, standard and two-compressor arrangement:

- **Single Deck** dehumidifier has same dimensions, features and options as standard single-compressor one, except for two compressor/refrigeration circuits instead of one.
- **“Double-Decker”** dehumidifier is shown on Pic. C.3. It is composed of two identical dehumidifiers, one installed on top of another and controlled as a single dehumidifier (each deck is equipped with one compressor/refrigeration circuit).

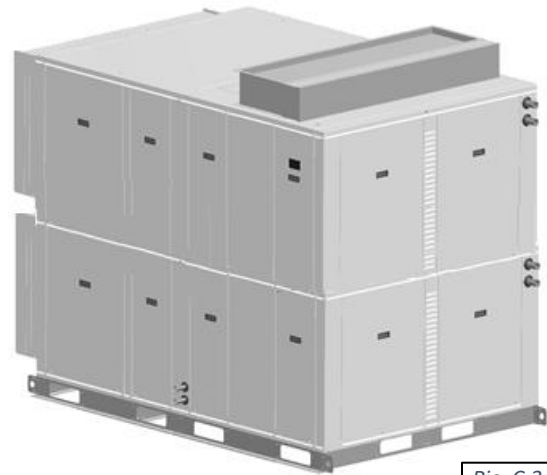

Pic. C.3

Single and Two-Compressor Arrangement – Dehumidifier Model

Dehumidifier typical arrangement, total capacity, and number of compressors are reflected in its model (for specific dehumidifier model refer to its Main Label – see **Specific Data Info** below):

- PCP3000 to PCP5000 models – single-deck single-compressor dehumidifier.

Two -compressor PCP series dehumidifier:

- PCP3030 to PCP5050 models - double-deck two-compressor dehumidifier, composed of two identical single-deck single-compressor dehumidifiers (thus doubling the capacity).

Most often, “Double-Decker” comes as two horizontal dehumidifiers, one “stacked” on the top of another, however it could also be composed of two dehumidifiers (horizontal OR vertical) installed side by side or separately, still being controlled as one.

Pool Water Heating Option – Bonding

Pool Equipment Bonding

The dehumidifier shall be bonded to the pool bonding and grounding system through the wiring lug installed for this purpose (example shown in the picture below). One side of the lug is connected internally to the pool water heat exchanger. This allows the dehumidifier to be part of the pool equipotential bonding system and prevents pool water heater corrosion.

⚠️ WARNING! Pool equipment bonding. Failure to properly bond the dehumidifier's pool water heat exchanger may cause failure which will not be covered under warranty.

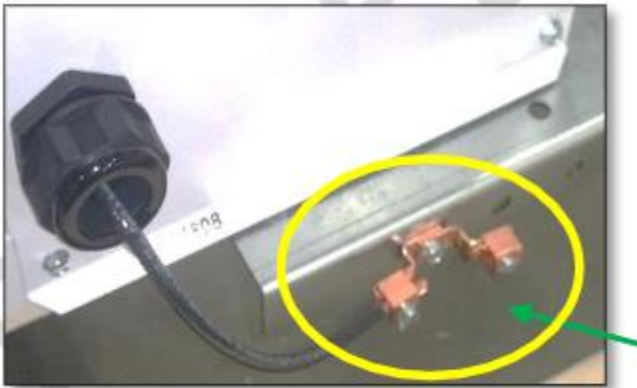

Air Conditioning Option - Outdoor Air Condensers (OACC)

Basic views of standard outdoor air condensers are shown on Pic.C.4-C (below); standard combinations of the dehumidifier and outdoor air condensers are shown in Table C.1.C

* Table C.1.C shows standard dehumidifier and condenser combination; depending on number of factors, dehumidifier may have different condenser provided with it - refer to the dehumidifier's submittal documentation for more details.

Table C.1.C Dehumidifier-AC Combination*		
Dehumidifier – Outdoor Condenser**		Fig.#
PCP0800 – PCP1200	NC-B	1
PCP0808 – PCP1212		
PCP1400 – PCP3000	NC-Z-1	2
PCP3500 – PCP 5000	NC-Z-2	3
PCP1414 – PCP3030		
PCP3535-PCP5050	NC-Z-4	-

Attention! Equipment Clearances!

Proper clearances should be maintained for adequate airflow and heat rejection! Generally, up to 36" side and 96" top clearances are required. For more information on clearances as well as equipment dimensions and other details, refer to the submittal documentation.

** Two-compressor dehumidifier would normally have paired-up two outdoor condensers of respective size (one per compressor). For example, PCP0808 would have double-condenser, composed of two NC-B (see Pic.C.4.C, Fig.1).

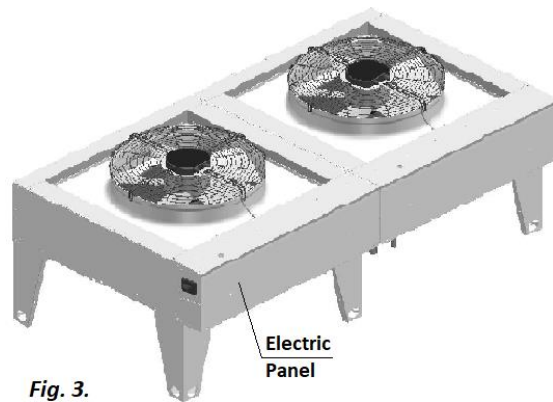
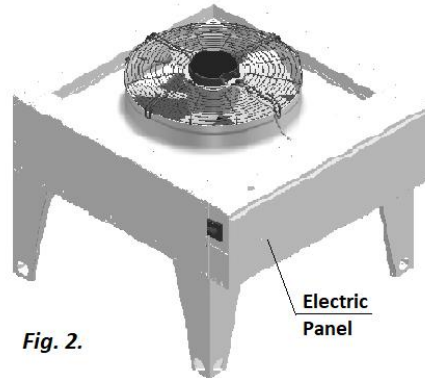
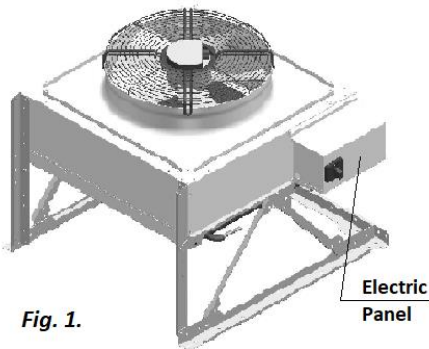

Pic. C.4.C

Air Conditioning Options - Fluid Coolers (O AFC).

Basic views of standard fluid coolers are shown on Pic.C.4.F (below); standard combinations of the dehumidifier and respective fluid coolers (based on their capacities) are shown in Table FC.1.

* Table FC.1 shows standard dehumidifier and cooler combination; depending on number of factors, dehumidifier may have different cooler provided with it - refer to the dehumidifier’s submittal documentation for more details.

** The pump package is optional - the fluid cooler may be provided without it.

Table FC.1. Dehumidifier-FC Combination*		
<i>Dehumidifier – Fluid Cooler**</i>		<i>Fig.#</i>
PCP0800 – PCP1200	NG-Z-1	4
PCP1400 – PCP2600 PCP0808 – PCP1212	NG-V-0	5
PCP3000 – PCP4000, PCP1414 – PCP1818	NG-V-11	6
PCP4500 – PCP5000, PCP2626 – PCP4040	NG-V-12	7
PCP4545 – PCP5050	NG-V-22	8

Attention! Equipment Clearances!

Proper clearances should be maintained for adequate airflow and heat rejection! Generally, up to 36” side and 96” top clearances are required. For more information on clearances as well as equipment dimensions and other details, refer to the submittal documentation.

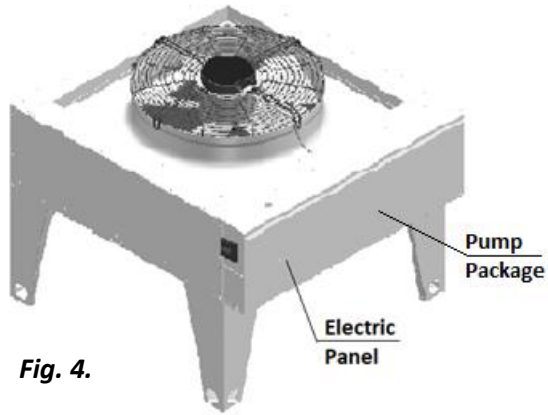

Fig. 4.

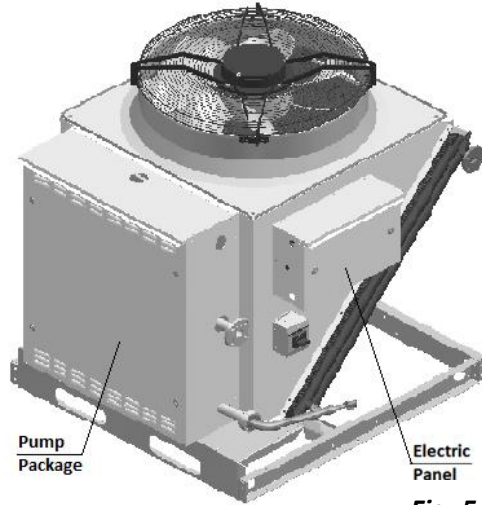

Fig. 5.

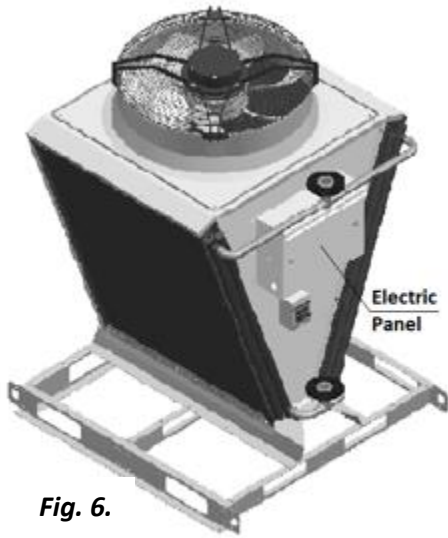

Fig. 6.

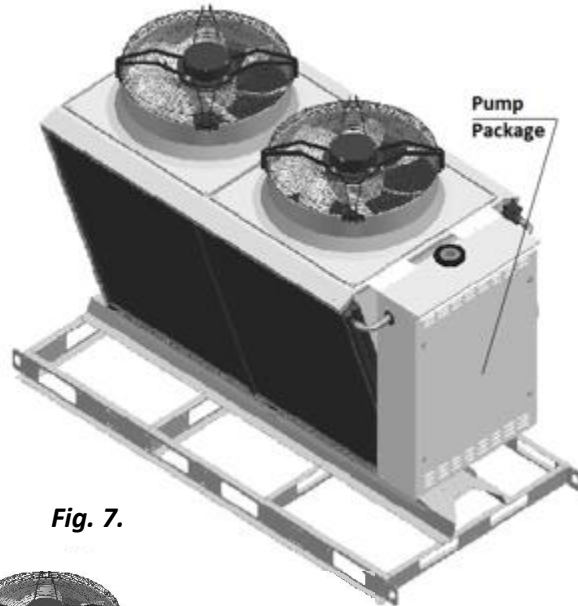

Fig. 7.

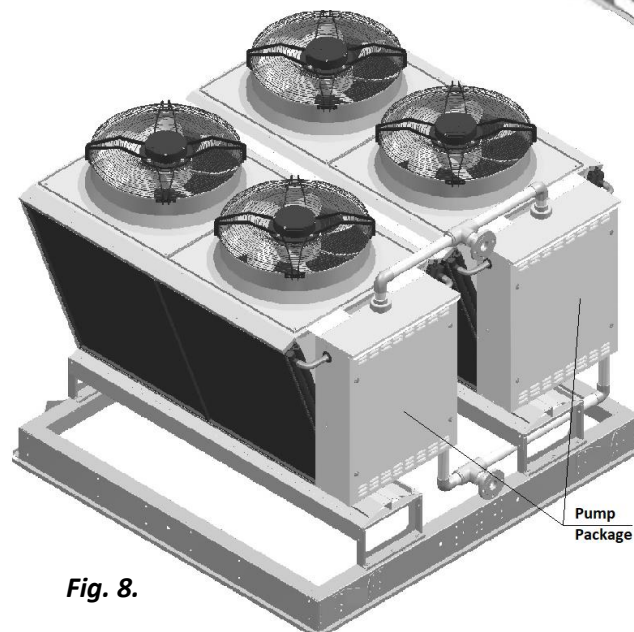

Fig. 8.

Pic. C.4.F

Equipment Specific Data

Specific information for individual dehumidifiers is provided in the following methods:

Main Label (Pic. C.5): the manufacturer tag attached to the front of the dehumidifier includes the dehumidifier's most critical data:

- ✓ General data including:
 - Serial number
 - Dehumidifier model (nomenclature)
 - Design room conditions (air temperature and humidity)
- ✓ Operational data, including:
 - Refrigeration (refrigerant type, charge, etc.)
 - Electrical/airflow (dehumidifier voltage, CFM, etc.)
 - Other applicable data (pool heating, space/auxiliary heating features, etc.)

Labels and Stickers: attached when applicable to the exterior and interior of the dehumidifier to show:

- ✓ External systems connections location/direction (pool/space heating, cooling circuits, condensate)
- ✓ Air filter locations, quantity, and size.
- ✓ Additional Info (warning, caution stickers, etc.)

Wiring Diagrams: attached to the interior side of the dehumidifier, depict dehumidifier control and power wiring.

PoolPak [®]				
General Data				
Serial Number : 16094015				
Unit Model : PCP-1400-PB-X-P3NB1162G2C4AD3				
Condenser Model : NC-B-1V-CUC-S				
Application : OUTDOOR USE				
Design Room Conditions : 75 °F 54 % R.H.				
Refrigeration Data				
Refrigerant Type : R410A				
Factory Charge (CKT 1) : 21 lbs Oil Charge (CKT 1) : 11 oz POE				
High Pressure Cutout (Switch) : 600 psig				
Low Pressure Cutout (Switch) : 50 psig				
Electrical & Airflow Data				
MCA (Minimum Wire Size) : 30.0		Use Copper Conductors Only		
MOP (Max Fuse or CKT BKR) : 45.0		System Voltage : 208/3/60		
<small>(HACR type NEC)</small>				
	Qty	Voltage	CFM	HP FLA
Supply Motor :	1	208/3/60	1600	2.2 5.0
Outdoor Air Intake :	-		400	- -
OACC Blower Motor :	1	208/1/60	-	0.6 2.6
Gas Heating Package :	1		-	- -
	Qty		LRA	RLA
Compressor Motor :	1		123.0	17.6
Pool Heating Data				
Pool Water Flow (Total) : 7.0 GPM		Pressure Drop : 3.0 psi		
Max. Inlet Pressure : 60.0 psi		Connection Size : 0.75 NPT		
Auxiliary Heating Data				
Gas Heater Output : 80 MBH		Gas Connection Size : 0.75 NPT		
Gas Pressure Input (Min/Max) : 7.0 / 14.0 in-H2O				
Boiler Loop Capacity : 7 U.S. Gal. 33% Propylene Glycol				
www.poolpak.com				MADE IN USA

Pic. C.5

Note: The main label shown above is just an example.

Remotely installed condenser or cooler would have its specific information provided in similar manner (labels etc.).

Attention! Glycol Circuits.

Unless otherwise indicated, equipment fluid circuits (except for refrigeration and pool water circuits) such as heat recovery loop, compressor glycol loop, fluid cooler etc., are normally filled/to be filled with water/glycol mixture; normally, rust inhibitor-infused food-grade propylene glycol is used.

Glycol mixture concentration is normally shown on Main Label – refer as needed.

Layout and Components

The general layout and components location is the same for all dehumidifiers of current type, however some may vary, based on the dehumidifier's specific options – refer to submittal documentation. Pic. D.1-S, D.1A-RV, D.1B-RH below show all/most available options, some of which may not be present on your dehumidifier. SLB cab is not shown but is more similar to the S cab.

Dehumidifier Main Components – S cab

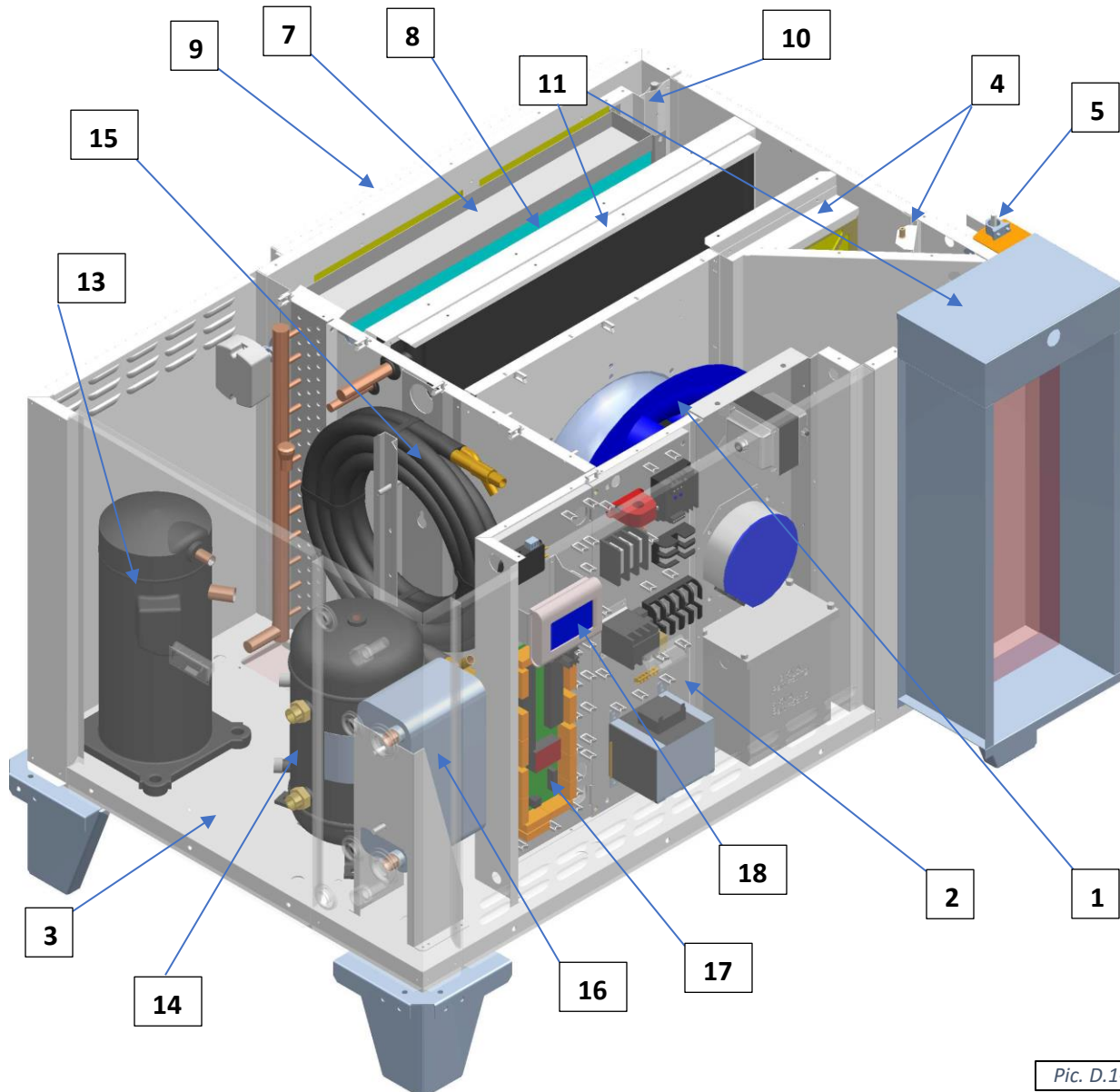

Pic. D.1-S

- **Main Blower (1)** is in the main blower compartment next to the **Main Electric Panel (2)** and **Compressor Compartment (3)**.

- **Min Outdoor Air (OA) Opening** (4) is optionally equipped with a motorized damper and filter(s). The **Manual OA Damper** (5) is usually used to set proper amount of outdoor air intake.
- Refrigeration coils - **Evaporator** (7) and **Reheat** (internal condenser) (8) - are located directly downstream of the **Main Filter Rack** (9).
 - **Evaporator Bypass Damper** (10) is located next to the evaporator coil. It helps to control compressor suction pressure by adjusting the amount of air, bypassing the evaporator.
- **Space heater** (11) location, if the dehumidifier is equipped with one, may vary:
 - **Hot water** coil is usually located directly downstream of the **reheat** coil;
 - **Electric heater** may be in the same place as the hot water coil or mounted directly on the dehumidifier's supply air duct connection.
 - **Gas heater** normally is installed externally.
- **Compressor** (13), **Receiver** (14) and other components are located within the **Compressor Compartment** (3).
 - If the dehumidifier has the standard pool water heating option, the compressor circuit includes the **coaxial pool water heat exchanger** (15) and refrigeration pool valve.
 - If the dehumidifier has the **water-cooled** air conditioning option (equipped with fluid cooler or connected to external water-cooling source), the compressor circuit also includes the **plate heat exchanger** (16)).
- **Main Electric Panel** contains **Main Control Board** (17), **Operator Panel** (18) and other electrical components.

Dehumidifier Main Components – RV and RH Cabs

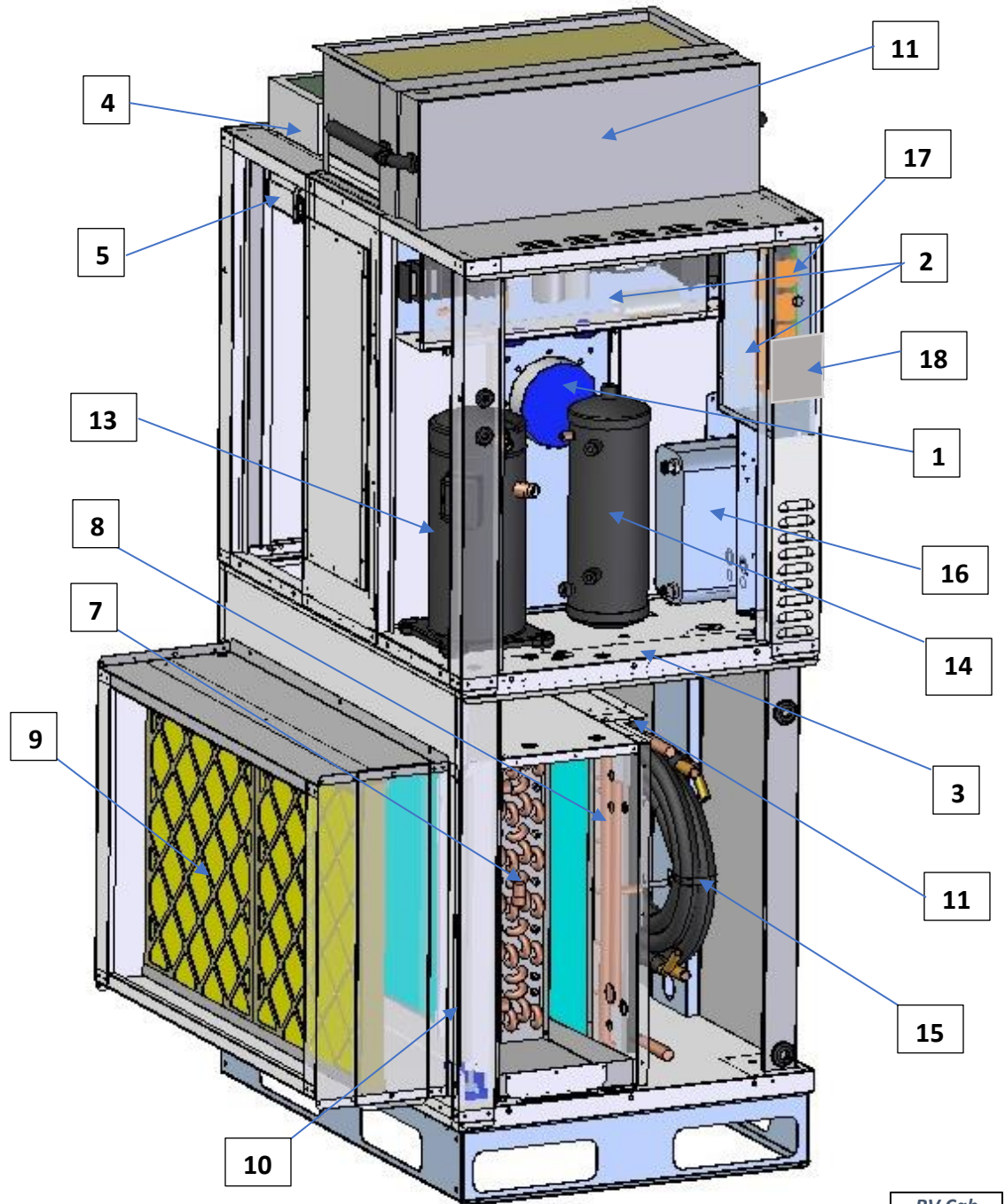

RV Cab
Pic. D.1A-RV

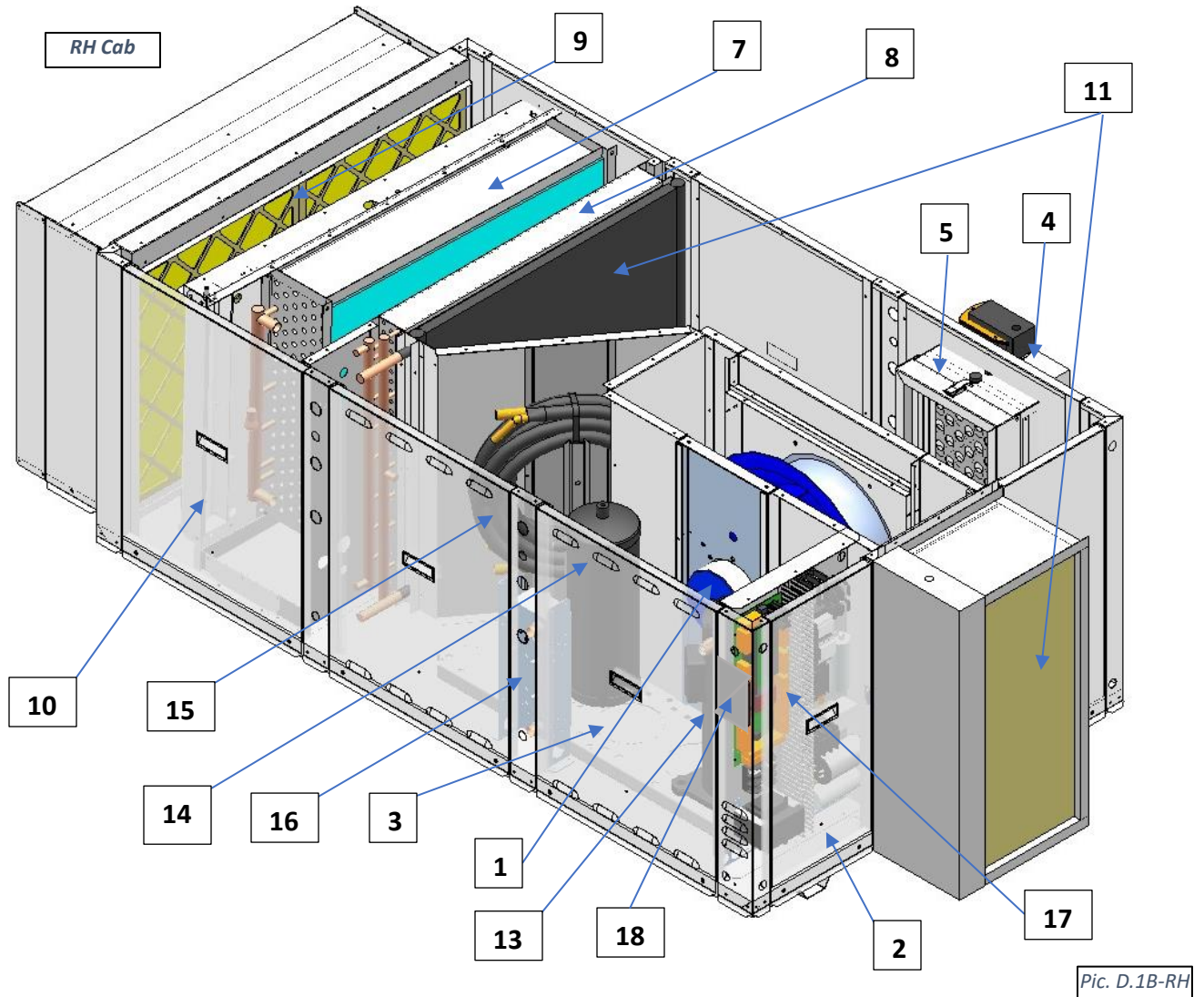

- **Main Blower (1)** is in the main blower compartment next to the **Main Electric Panel (2)** and **Compressor Compartment (3)**.
- **Min Outdoor Air (OA) Opening (4)** is optionally equipped with a motorized damper and filter(s). The **Manual OA Damper (5)** is usually used to set proper amount of outdoor air intake.
- Refrigeration coils - **Evaporator (7)** and **Reheat** (internal condenser) (8) - are located directly downstream of the **Main Filter Rack (9)**.
 - **Evaporator Bypass Damper (10)** is located next to the evaporator coil. It helps to control compressor suction pressure by adjusting the amount of air, bypassing the evaporator.
- **Space heater (11)** location, if the dehumidifier is equipped with one, may vary:
 - **Hot water coil** is usually located directly downstream of the **reheat coil**;
 - **Electric heater** is usually mounted directly on the dehumidifier's supply air duct connection.
 - **Gas heater** (duct heater or boiler package) normally is installed externally (not shown).

- **Compressor (13), Receiver (14)** and other components are located within the **Compressor Compartment (3)**.
 - If the dehumidifier has the standard pool water heating option, the compressor circuit additionally includes the **coaxial pool water heat exchanger (15)** and refrigeration pool water heating valve.
 - If the dehumidifier has the **water-cooled** air conditioning option (equipped with fluid cooler or connected to external water-cooling source), the compressor circuit also includes the **plate heat exchanger (16)**.
- **Main Electric Panel** contains **Main Control Board (17)** and other electrical components.
 - Vertical dehumidifier normally has **Main Control Board** mounted in the additional control sub-panel, within **Compressor Compartment** and separately from **Main Electric Panel**.
 - **Operator Panel (TouchDisplay)** could be installed inside the dehumidifier (normally – in the compressor compartment) or provided separately for field installation. Feasible field installation options include **OP mounting plate (18)** on the corner post or elsewhere in mechanical room or maintenance office (see **Interface and Communication** for details).

Control System

The dehumidifier control system is composed of sensors, spread throughout the dehumidifier, **Main Control Board**, **Operator Panel** and other electric components, located in the **Main Electric Panel**.

Temperature Sensors (Pic. D.2):

- a) **Temperature** sensors (thermistors) are used to monitor various temperatures (air, water, compressor, etc.);
- b) **Combo** sensor is used to monitor air temperature and humidity.

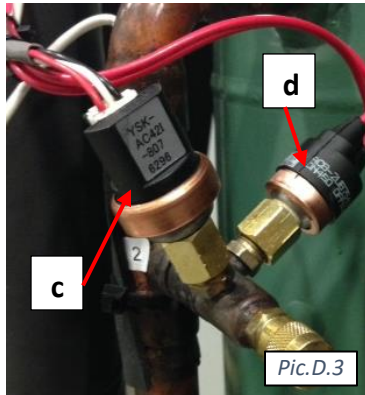

Compressor operation is monitored with **pressure sensors** (Pic. D.3):

- c) **Pressure Transducers** (as main operational control and safety) and
- d) **Pressure Switches** (fast-reacting backup safety).

Sensors and safeties approximate location is shown on Pic. D.4-S and D.4-R (see below).

- **RA Combo Sensor** (21) measures temperature and humidity of the pool room air (Return Air) entering the dehumidifier. It is located at the return air ductwork connection to the dehumidifier.
- **OA Temperature Sensor** (22) measures outdoor air temperature; it's located at the OA filter rack.
 - As an option, the combo sensor (instead of regular thermistor) can be installed at the OA intake to measure both the temperature and humidity of the outdoor air.
- **ET (EvapT) Temperature Sensor** (23) measures the temperature of air leaving evaporator coil. It's located directly downstream of the evaporator.
- **SA temperature sensor** (24) measures the temperature of the air leaving the dehumidifier (supplied to the premise). It must be located downstream of the space heater:
 - In some cases, where the space heater is external to dehumidifier, the sensor will be provided with the dehumidifier to be field-mounted into the supply air ductwork downstream of the space heater.
- If the dehumidifier is equipped with the pool heating option, the **Pool Water Temperature sensors (Pool In (25) and Pool Out (26))** measure the entering and leaving pool water temperature. The sensors are located directly at the respective connections of the coaxial pool water heat exchanger.
 - As an option, the pool water heat exchanger piping/manifold may have water flow switch also.
- The compressor's discharge line (high pressure side) is equipped with **Temperature and Pressure sensors set - Discharge Temperature Sensor, High Pressure Transducer and High Pressure Switch (27)** - to protect the compressor and control its operation. A similar function is performed by **Suction Temperature Sensor, Low Pressure Transducer and Low Pressure Switch (28)** located at compressor's suction line (low pressure side).
- **Main Electric Panel**, apart from devices listed above (control board, OP, etc.) also contains **Voltage Monitor**; some optional control sensors and devices such as an air pressure differential sensor, current sensor(s). It may also be located in main electrical panel or in the dehumidifier in general.

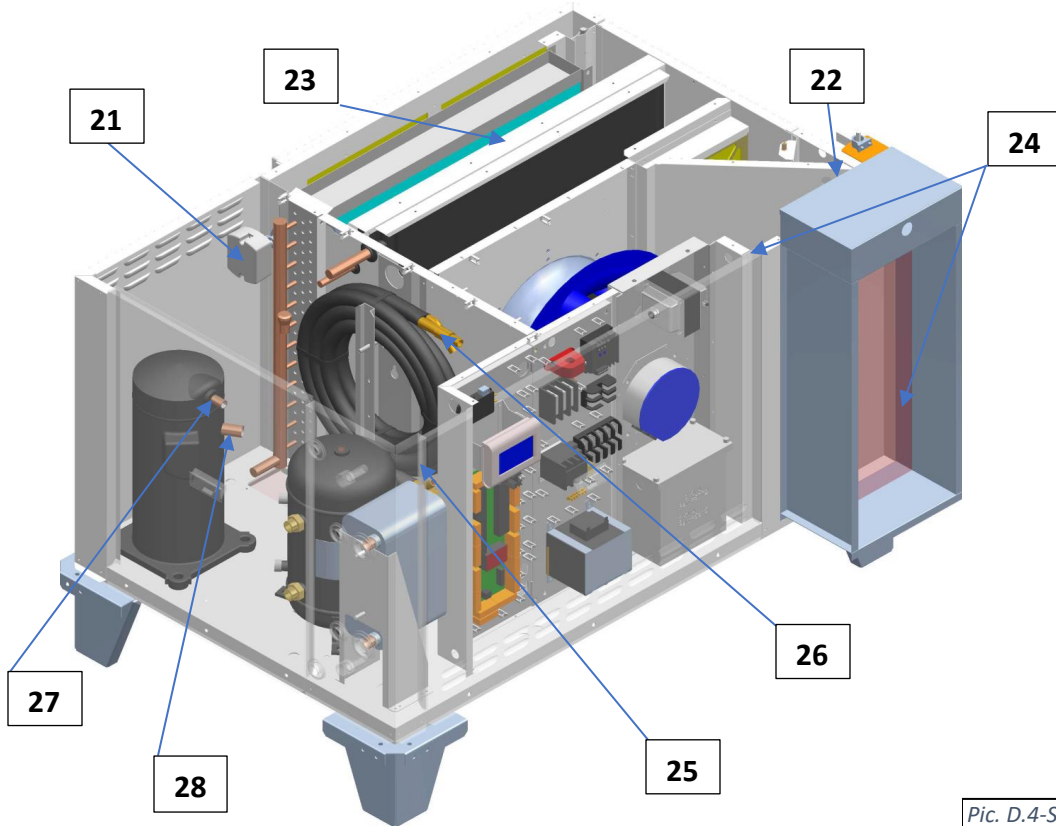

Pic. D.4-S

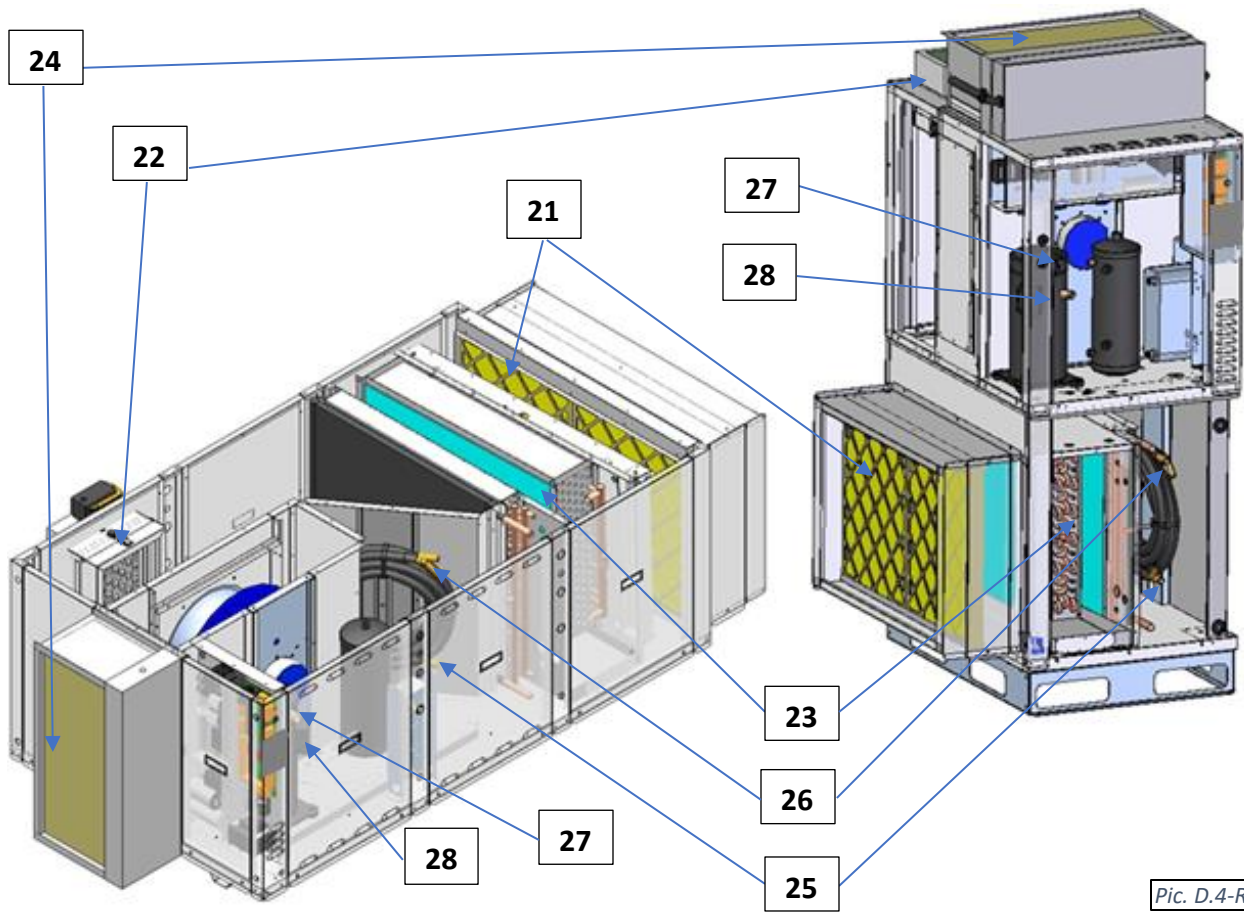

Pic. D.4-R

Outdoor Air Condensers and Fluid Coolers Layout and Components.

The general layout of AC options (air-and water-cooled) is shown on Pic.D.5 below with the outdoor air condenser NC-Z-1 (left) and fluid cooler NG-V-11 (right) as an example. While layout and main components are similar for all applicable AC options, there are some deviations (number of fans, coil sizes, composition, etc.). Refer to **AC Options Basic View (Basic Information)** for additional information.

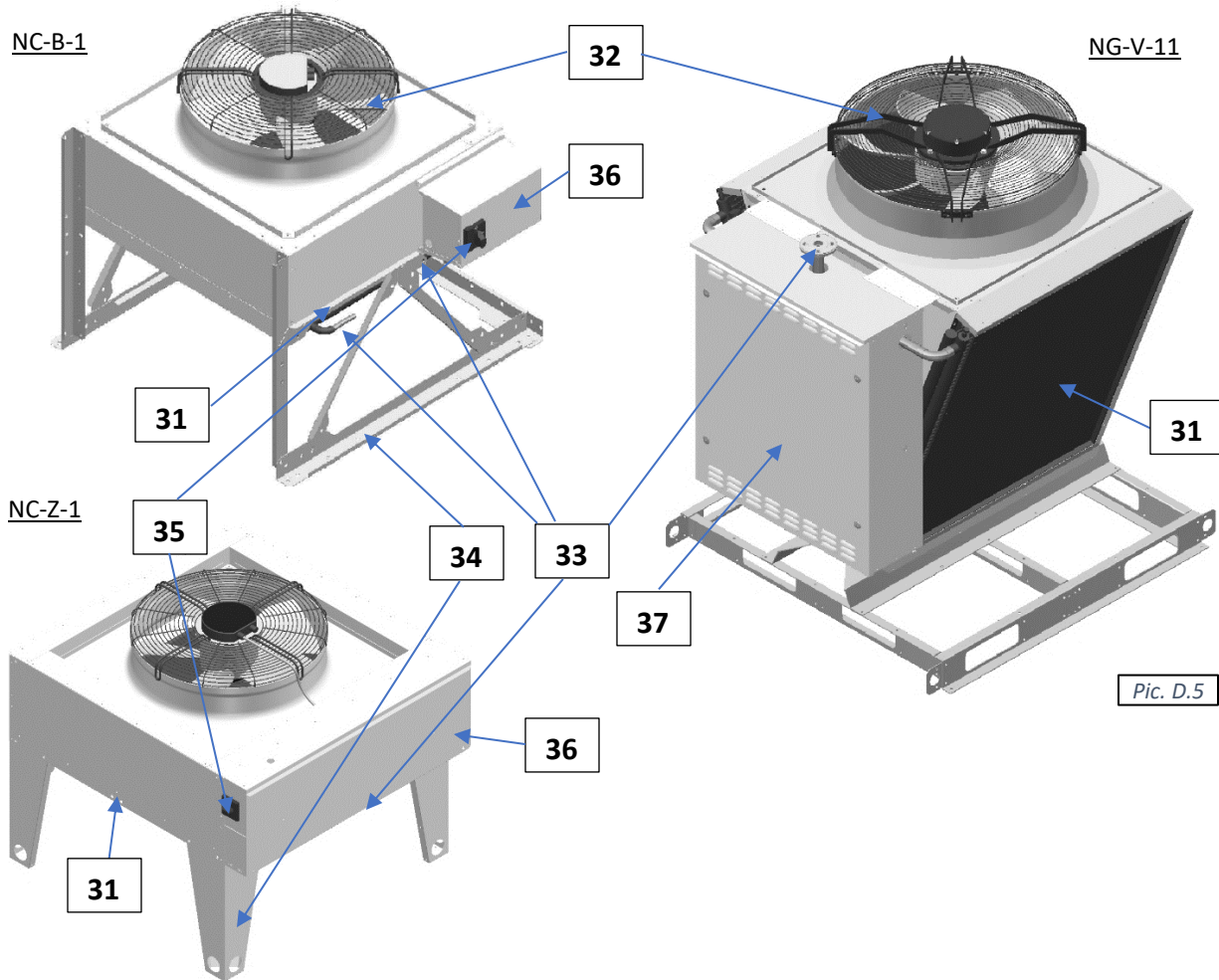

- Cooling (AC) **coil(s)** (31) (where heat from refrigerant in the outdoor condenser or glycol mixture in fluid cooler is rejected to the ambient air) is mounted onto metal frame/air box upstream (before) the **fan** (32), that pulls the air through the coil to absorb the heat.
 - Condenser/cooler **piping connections** (33) are identified respectively (IN – OUT, Hot gas – Liquid etc.);
 - In some cases, fluid cooler piping connection(s) may be located within **pump package box** (37), if fluid cooler is provided with one.
 - Piping connection location may vary – refer to particular cooler/condenser labels, stickers, submittal and other documentation.
 - Depending on the type, size and installation, outdoor condensers may be provided with different set of **legs/supports** (34), which are required assembly on-site – refer to the Installation manual.

- Depending on the size and capacity, condenser or cooler may have multiple fans or coils.
- Electric power is normally to be brought to **disconnect** (35) (if cooler/condenser is equipped with such), which feeds it to the **electrical box** (36), that contains condenser or cooler power and control apparatuses.
 - *Condenser's* piping manifold/connections normally are protected by the electrical panel cover;
 - Depending on type of *fluid cooler*, location of electrical box may slightly differ; in some cases, electrical box may be incorporated into pump package.

Fluid Coolers Pump Package.

Fluid Coolers, if equipped with such option, would have a **pump package** box. Pic.D.6 below shows general layout of pump packages, used for *NG-Z* (left) and *NG-V* (right) fluid coolers. Note, that the package used with NG-V coolers could be mounted onto the fluid cooler directly (standard) or provided separately.

- **Pump** (38) establishes glycol mixture circulation through the fluid cooler and dehumidifier;
- **Expansion tank** (39) compensates for temperature-based glycol volume fluctuation;
- The pump package **electrical sub-panel** (40) contains the pump package electrical power and control apparatuses.
- The pump package manifolds are usually equipped with pressure gauges, automatic air venting valve, draining and other valves.

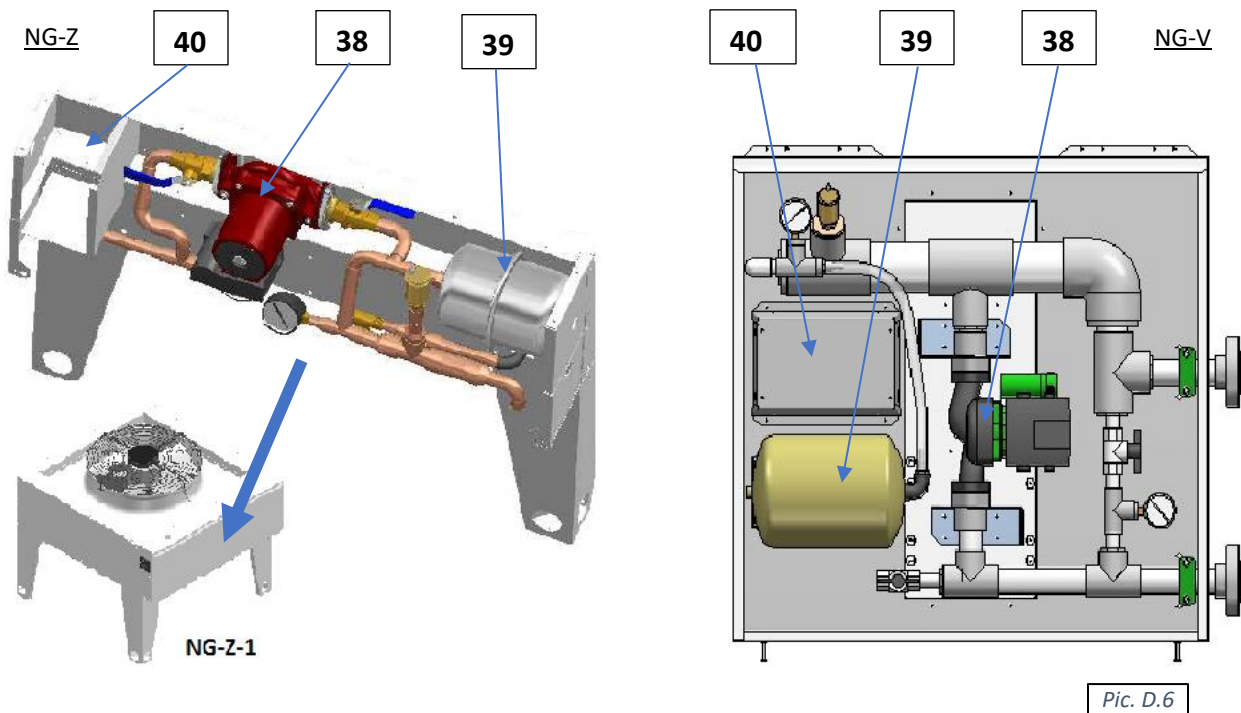

Sequence of Operation

The dehumidifier's ventilation system establishes the required airflow through the dehumidifier. The control system compares air temperature and humidity to their desired values (set points) and proceeds to dehumidify, cool or heat the recirculating air.

If the dehumidifier is equipped with the pool water heating option, the pool water temperature is compared to its set point and pool heating is provided if required.

Set Points

The control system is constantly adjusting unit operation to achieve and maintain said parameters within couple degrees/percent of the set point.

Refer to the dehumidifier's main label for the design value of control parameters, as well as the following note.

Note: To ensure the dehumidifier's most economical operation, we recommend maintaining the following relationship between pool water and room air temperatures:

$$\text{Room Air T} = \text{Pool Water T} + 2^{\circ}\text{F}$$

Ventilation.

The **main blower** runs continuously, establishing required airflow and pulling fresh outdoor air onto the premise through the minimum **outdoor air** intake (OA1) damper. The main blower speed is pre-set via adjustable variable signal.

Dehumidifier, though usually does not have it built-in, can control the external **minimum exhaust fan** (EF1), to directs portion of return air outdoors. Like the main blower, exhaust fan speed is controlled via adjustable (pre-set) variable signals: the exhaust fan speed may vary depending on scheduled ventilation mode (Occupied, Non-Occupied and Spectator) or call for Economiser Mode (as part of Air Conditioning and/or Dehumidification operation).

- **Note.** Externally installed Exhaust Fan(s) and Outdoor Air damper(s) could be also controlled by the dehumidifier control system. This applies to both, Minimum and Purge/Additional, fans and dampers.

Space Heating

When premise air temperature drops below the set point, the dehumidifier control system issues a call for Space Heating Mode and engages space heater (electric heater, hot water coil with valve, etc.) by sending space heating signal, respective to space heater control type - on/off, variable (0-10VDC), etc.

Air Conditioning, Dehumidification and Pool Heating.

Compressor(s)

Whenever the compressor operates, the evaporator is always dehumidifying and cooling the return air. The heat removed from the air at the evaporator, as well as the heat from the compressor's action, must be rejected to one of three heat sinks: room (premise) air, pool water (if applicable) or outdoors. The control system will direct the heat to where it is needed based on room (air and pool water temperature) conditions:

- If room air is needed to be warmed up – more heat is diverted towards reheat coil;
- If pool water is needed to be warmed up – more heat is diverted towards pool heating coaxial heat exchanger (if dehumidifier is equipped with this option).
- Rest of the heat (if any) is diverted towards outdoors (outdoor condenser, fluid cooler, etc.)

Compressor Circuit Operation

Piping schematic for compressor circuit is shown on Pic. E.1.

When a demand requires the compressor to operate, the following sequence occurs:

- Once blower operation, related safeties and timers are confirmed by the control system, the pump down solenoid valve opens and once pressure stabilizes, the compressor starts.
- Based on the premise air temperature, the refrigeration reheat and/or AC solenoid valve opens, allowing refrigerant to flow through the respective condenser:
 - if more heat is required by the room air, the reheat solenoid valve opens (heat is rejected to the premise); if more cooling is required by the room air, the AC solenoid valve opens (heat is rejected outdoors (via outdoor condenser or plate heat exchanger).
 - Outdoor condenser or fluid cooler fan is engaged only if hot gas is diverted outdoors and compressor pressure is higher than pre-set level (see **Outdoor Condenser and Fluid Cooler Operation** below).
- Dehumidifiers, equipped with pool water heating option, also engage the refrigeration pool water heating solenoid valve to reject heat into the pool water, based on pool water temperature.
- Once demand for the compressor's operation is removed (respective call is satisfied), the pump down solenoid valve closes; once the compressor suction pressure reaches the pre-set pressure, the compressor stops.

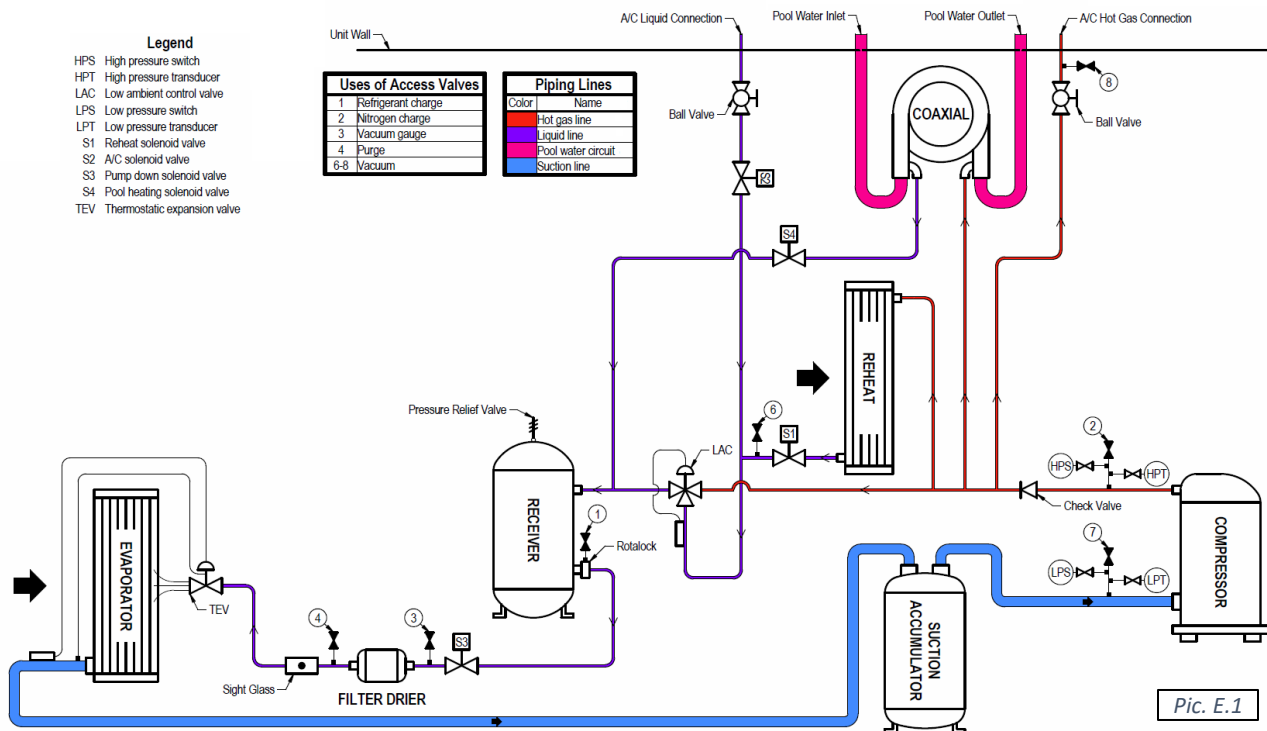

Pic. E.1

Note. Suction accumulator is not typically found on 2-7 ton models.

Outdoor Air Condenser and Fluid Cooler Operation.

Based on the type of the outdoor condenser or fluid cooler fans' type (two-speed fans or EC-type/modulating fans), respective signal(s) are sent by control system to engage said fan(s): for two-speed fans - on/off signals (switching speeds, based on compressor head pressure level), for EC-type fans - variable 0-10VDC signal (proportional to the compressor head pressure level). Refer to the fans' type and wiring diagram if/when needed.

If the fluid cooler is equipped with the built-in pump package (to establish cooling fluid flow between dehumidifier and the fluid cooler or to serve as additional/booster pump), the said pump is also engaged along with fluid cooler fans – pump would stay engaged while fans are engaged (regardless of the fans' speed).

Interface and Communication

Touch Display Operator Panel

The Touch Display Operator Panel (OP), shown on Pic. F.1, is used as a main interface between the dehumidifier and operator. The same OP can be located in the dehumidifier main electric panel (default; used as a local OP) or installed remotely from the dehumidifier

- **NOTE:** length of CAT5 or CAT6 cable, between remote OP and the dehumidifier MUST NOT exceed 1000'!



Pic. F.1

Touch Display OP allows to:

Access Touch Display **Menus**

View dehumidifier current operational statuses (Touch Display Communication, Alarms, dehumidifier operational calls, etc.)

View controlled parameters' values (premise air temperature, humidity and, if applicable, pool water temperature) and current date and time.

Touch Display Menus:

Home	Opens/returns to the home page
Logs	Access to dehumidifier logs and log-related features (Alarms , etc.)
User	Access to user settings (Setpoints) and commands (Stop/Restart Dehumidifier, etc.)
Advanced	Access to advanced settings and features
Help	Context sensitive help presenting information related to the viewed page

Most common/basic maintenance tasks performed using Touch Display OP

- ✓ **Adjust Setpoint** – in **User** menu: press the **User** button, then press the **Setpoints** button; select desired parameter (room air temperature etc.) and enter the desired value. Press the **Enter** button to confirm the entered value.
- ✓ **Stop/Restart Dehumidifier** — in **User** menu: press the **User** button, then press the **System Restart** button;
 - To stop and restart dehumidifier, press the **System Restart** button
 - To reboot Touch Display OP, press the **Restart Display** button
- ✓ **Review Alarm records** — done via the **Logs** menu: press the **Logs** button, then press the **Alarm Log** button.
- ✓ **Unlock device/dehumidifier, stopped and currently locked out on the alarm** — done via **Logs** menu: press the **Logs** button, then press the **Current Alarms** button; press the **Clear** button next to the respective alarm (the alarm that's locked out the device or entire dehumidifier).

For detailed information on TouchDisplay OP refer to **CommandPak® Control System Touch Display User Manual**, provided with the dehumidifier (or contact factory to obtain a copy).

Alarms

If the dehumidifier control system detects abnormal or unsafe for further operation situation, it issues **Alarm** (notification of such situation accompanied by respective component or entire dehumidifier stoppage and/or lockout) or **Alert** (notification of minor abnormal situation without any devices' stoppage or lockout).

All alarms and alerts are recorded and can be viewed/cleared via the Touch Display OP:

- ✓ Viewed: to facilitate troubleshooting and addressing abnormal situation
- ✓ Cleared: to unlock stopped device or entire dehumidifier and allow for further operation

The table F.1 below lists the basic alarms with their descriptions and recommended initial troubleshooting.

Alarm	Alarm Description	Check
No Air	No air flow (air flow switch fault – <i>if air flow switch is installed</i>)	Check main blower operation and air flow switch
Blower OL	Main Blower overload/safety fault	Check main blower operation and its LED light blinking pattern.
Fire	Fire/smoke detector fault – <i>if detector is installed externally and connected to control board</i>	Check external fire/smoke detector/system
Freeze	Supply Air temperature is lower than Freezestat Setting (default: 45 F)	Check SA temperature readout, space heating system operation
Filter	<u>Alert</u> , indicating that filter change timer has lapsed – <i>if timer is activated</i>	Clear the Filter alarm and cancel filter scheduler if not in use.
VM	Voltage Monitor fault – power supply (phasing, voltage etc.) is outside of pre-set limits	Check Voltage Monitor info/status, incoming power (voltage)
Compressor: - HP1-(X) - LP1-(X) - SupHeat1 - DisTemp1	Various compressor-related alarms, relevant to: - Compressor high/discharge pressure; - Compressor low/suction pressure; - Compressor superheat/suction temperature;	Check respective compressor-related data (pressure and temperature readouts), refrigerant level in the receiver's sight glasses, cleanliness of air-side coils and air filters.
Pool Water: Water(X)1, Wtr(X)1	Various compressor pool water heating-related alarms indicating inadequate (too low/too high) pool water flow and/or pool water temperature.	Unless the alarm occurred due to a known water flow interruption (backwash, etc.), check the pool water flow (pump, filters, valves) and pool water temperatures.
HPRelief	<u>Alert</u> , indicating that additional condensing capacity is engaged (pool water heat exchanger etc.) to prevent compressor high pressure from rising too high.	No action required unless it's accompanied by other (compressor-related) alarm or faulty situation.

- ✓ Note that proper and regular maintenance (example: keeping air filters and air-side coils clean) should reduce the chances of abnormal operations, dehumidifier alarm-related stoppages and downtime.

 **CAUTION!** We recommend you have a qualified professional investigate and remedy all reoccurring alarm-related stoppages and lock-outs. Continuous dehumidifier restarting (clearing alarms) without addressing actual issues may result in equipment malfunction, premature wear, and failure.

For more details regarding alarms and alerts, refer to the **Alarms Description** information (available via Help feature in Touch Display OP); contact factory if needed.

Remote Communication

Although dehumidifier is designed to operate as a self-controlled device (not requiring any external control), communication between the dehumidifier and external control and monitoring systems is possible.

WebSentry

WebSentry is an online tool (also referred to as Web Monitor), that allows for remote communication to the dehumidifier for various purposes such as monitoring, data collection, parameters adjustment, and notifications. This feature is included with all dehumidifiers and is useful for maintenance teams and service providers (HVACR technicians).

To establish Web Monitor communication, the dehumidifier must communicate with the factory server via the Internet:

- Connect the dehumidifier to a local network switch, router or wireless AP device (providing connection to a local network):
 - o Plug an Ethernet cable into the sub-board Ethernet RJ-45 jack (sub-board, called Core Module, is located on the main control board in the main electric panel) – see Pic. F.2.
 - **Note:** separate RJ-45 jack (plastic, black) is mounted on the control board directly, for TouchDisplay connection. Make sure to use the proper jack (metal-surface one, located on the sub-board) for Web Monitor connection.
- Configure, as needed, local server and dehumidifier network settings.

BMS (Building Management System)

Communication to BMS can also be supported, depending on the type of communication protocol said BMS utilizes.

The equipment control software supports most common of them

- different control software variation might be required to support different BMS communication protocols. Contact factory if necessary.

BACnet (Internet, IP). Communication is established via the Ethernet cable (same method as Web Monitor).

- ✓ BACnet and Web Monitor communication can be used simultaneously.

LON or Modbus. Communication requires external wiring between dehumidifier main control board and BMS terminal. Wiring schematic is normally indicated on wiring diagram (provided with dehumidifier).

- ✓ If dehumidifier is equipped with LON communication option, it's normally provided with pre-wired LonWorks Gateway for communication purposes.

For more information about Web Monitor or BMS communication set up (connection, configuration, access, point cutsheets, etc.) – contact factory.

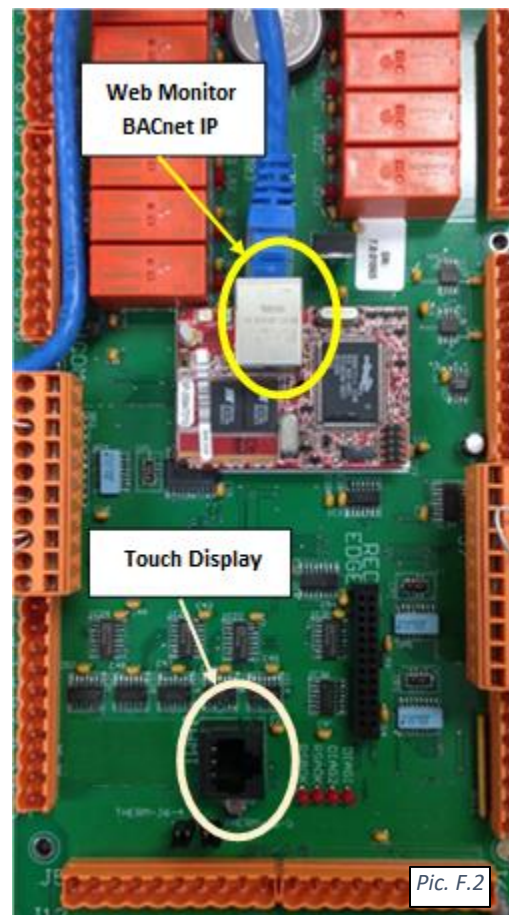

Basic Maintenance

Although PoolPak equipment is built for minimal service downtime, periodic preventative maintenance is required to ensure maximum reliability, safety, and operating efficiency.

 **WARNING!** To ensure equipment longevity and proper and efficient operation, the dehumidifier and its auxiliary systems and devices (outdoor condenser, fluid cooler, boiler package, etc.) **must be maintained** properly and regularly. It is recommended to create a **facility-specific Routine Maintenance Program**. Failure to maintain the equipment properly and regularly could result in personal injury, equipment damage or malfunction and will void the equipment warranty.

Maintenance and Safety

Only qualified/properly trained personnel should attempt to perform respective maintenance tasks.

- When it is necessary to work with live electrical components, have a licensed electrician or other qualified professional perform the required task.
- **Be properly trained and equipped.** Some maintenance tasks may involve usage of power tools, chemicals, etc. Refer to such tools and materials data (manuals, MSDS, etc.). Personnel performing such maintenance tasks should be:
 - Properly trained to handle such tools and materials safely
 - Equipped with proper personal protective equipment
- **Turn the power off.** Before performing any maintenance, disconnect all electrical power, including remote disconnect, and discharge all energy storing devices (VFDs, etc.) before servicing. Follow proper lockout procedures to ensure that power cannot be accidentally restored. Failure to follow provided safety warnings and labels could result in serious injury or death.
- **Be aware of potential hazards.** The Equipment contains moving mechanical parts, components under high refrigerant pressures and surfaces with high temperatures. Before entering the dehumidifier and/or performing any equipment maintenance work, make sure that all moving parts are stopped, and it is safe to perform required task.

Maintenance Key Points

Here are some basic/key maintenance considerations, pertinent to all dehumidifiers and their auxiliary systems:

- Dehumidifier in mechanical room. **No chemicals** should be stored **in the same mechanical room** where the dehumidifier is installed. Chemical fumes/off-gas can cause premature deterioration of the equipment.
 - Store chemicals in a separate, well-ventilated room.
- Access to the Equipment. Ensure that the **equipment is accessible** (minimum clearances are maintained): approaches to the dehumidifier are not restricted/limited with materials in mechanical room (indoor installed) or with snow (outdoor installed dehumidifiers, OACC and O AFC).
- “MUST DO” maintenance task. Although all other maintenance tasks are as important, these two maintenance tasks are the most common and most helpful:
 - Maintain **clean air filters** (return, outdoor air filters, etc.). Make sure to replace dirty filters regularly.
 - Maintain **clean air-side coils** (especially Outdoor Condenser or Fluid Cooler). Make sure to clean coils regularly.

- Pool Water Chemistry. Incorrect pool water chemistry (improper pH level or high concentration of chlorine, sea salt or other corrosive additives etc.) can result in equipment premature wear or malfunction (let alone poor air quality in the pool and potential health issues) and will void the equipment warranty. Refer to pool water quality standards; contact factory as needed.

Routine Maintenance Program

Creating facility-specific routine maintenance program and following it is vital to equipment longevity and efficient operation.

The suggested general maintenance operations and their frequency/intervals, listed in the table M-1 below, can be used to create such a program. For more detailed maintenance recommendations related to specific components, refer to the respective component manufacturer’s manual.

Table M.1. Recommended Maintenance Tasks and Intervals	
Interval	Maintenance Task
Weekly	Observe the equipment for any changes in running conditions and unusual noise
Quarterly	Clean or replace air filters if clogged or dirty
	Verify that all set-points are correctly programmed as specified by the facility operator
Semi-Annually	Inspect and clean the drain pan(s)
	Tighten electrical connections, if required
	Check and tighten, if required, pool water hose clamps and sensor mounts
	Inspect all airside coils (outdoor condenser, fluid cooler, dehumidifier coils – evaporator, etc.) for dirt, cobweb build-up, etc.; clean as needed
	Check that the P-trap is primed (filled with water). It is good practice to pour some water into the drain pan to ensure that the P-trap is primed and operational
	Check the outdoor air louvres and dampers for accumulation of dust and clean as required
	Inspect the equipment’s cabinet for corrosion. If any damage is found, clean and repaint the affected surface with a rust-resistant primer
Annually	Clean the fan wheel(s)
	Check dampers operation (linkage/actuator is not loose, damper opens/closes properly etc.)
	Inspect electrical components, wiring and insulation
	Rotate the fan wheel(s) and check for obstructions and rubbing
	Check gasket condition on all doors to ensure an airtight seal
	Check bolts on compressors, motor mounts, dehumidifier bases and coils and tighten if required
	Verify that the airflow around the remote condenser or dry cooler is unobstructed

Specific Components Maintenance

Actual maintenance plan may vary from installation to installation, yet there are several key components from maintenance prospective.

If needed, contact respective component manufacturer for additional maintenance information.

Filters

- Ensure air filters are clean. Dirty air filters will negatively affect dehumidifier performance and lifetime
- Frequency of filters replacement will vary based on air quality, dehumidifier usage, facility type, etc. Make sure to replace filters regularly
- Replace with filters of equivalent size and rating – refer to dehumidifier details (compartment stickers, etc.)

Insulation

Inspect dehumidifier insulation, exposed to airstream for microbial growth (i.e., mold). If there is evidence of microbial growth on the interior insulation, the insulation should be removed and replaced prior to operating the dehumidifier.

Air-Side Coils

- **Warning: Hazardous chemicals!** Cleaning agents can be highly acidic or alkaline. Handle all chemicals carefully and use appropriate personal protective equipment (PPE). Refer to the cleaning agent manufacturer's Materials Safety Data Sheet (MSDS) for safety and handling information. Failure to follow all safety instructions could result in serious injury or death.
- **Warning: Hazardous pressures!** Coils containing refrigerant under pressure must not be cleaned using a solution over 150 °F. Failure to follow these safety precautions could result in coil bursting, which could result in serious injury or death.

To clean the coil

- Disconnect all electrical power to the equipment
- Use a soft brush to remove loose debris from the coil
- Mix a high-quality coil cleaning detergent with water according to the manufacturer's instructions
- Clean coil according to suggested instructions
- Thoroughly rinse both sides of the coil and the drain pan with, clean water
- Straighten any coil fins that have been bent during the cleaning process
- Confirm the drain line is clear
- Replace all panels and parts and restore electrical power to the equipment

Special Maintenance Tasks. Fluid Cooler Winterization.

Normally fluid coolers are used in the systems, filled with glycol mixture to prevent the system and the fluid cooler from freezing and, potentially, rupturing, when exposed to temperatures below freezing point.

When fluid cooler is used with media that, when exposed to low temperatures, could freeze (water or lower-percentage glycol mixture), one way to protect the equipment is to drain it (also known as “winterization” of the equipment).

Though fluid cooler itself is normally equipped with means to be drained properly/fully, it is recommended to have same means in place for entire system (fluid cooler – piping – dehumidifier etc.):

- Have each local high point of the system equipped with means to bleed the air (air bleeding valve etc.)
- Have each local low point of the system equipped with means to drain the fluid.



CAUTION. Draining and re-filling the fluid cooler must be performed by trained personnel, according to proper field practice and system layout. Improper draining or re-filling the system could lead to equipment damage, malfunction, premature wear and tear and may void equipment warranty.



CAUTION. Ensuring that the fluid cooler and associated system(s) equipped with proper means of draining, creating draining and re-filling procedures as well as determining whether draining is warranted to protect the equipment is outside of manufacturer’s scope and is a responsibility of installing contractor and local maintenance team.

Pools – Equipment Warranty

General Policy

All PoolPak service and warranty work are managed exclusively by Dehumidified Air Services (DASV). All warranties apply to the original equipment owner and are not transferable. All warranty inquiries should be made to Dehumidified Air Services.

Dehumidified Air Services:

Phone: 1-833-327-7665 Email: Warranty@DehumidifiedAirServices.com

PoolPak warrants as set forth and for the time periods shown below that it will provide through either a DASV Service Technician or an authorized service organization specified and approved by DASV, a new or rebuilt part to replace a factory installed part which has failed because of defect in workmanship or material.

NOTE: EVERY REQUEST RELATED TO WARRANTY OF ANY NATURE AS DESCRIBED BELOW MUST BE OFFICIALLY AUTHORIZED AND DOCUMENTED IN ADVANCE BY DASV TO QUALIFY FOR WARRANTY COVERAGE.

Warranty Void Unless Registered

All Warranties are void unless the start-up of the equipment is approved by a DASV service technician. Upon completion of the start-up, a “Warranty Registration Certificate” will be issued, along with the Start-up Report, which activates the Warranty Period of the equipment. The Warranty Period will commence either upon completion of start-up registration of the equipment or 6 months from factory ship date, whichever comes first.

Initial 90-Day Comprehensive Warranty

During the first 90 days from initial start-up, all parts and repairs related to factory defects or replacement parts are covered by PoolPak manufacturer warranty. All parts and labor requirements will either be handled by DASV technicians directly or managed and approved in advance by DASV through DASV authorized technicians.

Internet Connected, Conditional One Year Repair Warranty

If and only if the equipment is connected to the internet from the date of warranty activation, a Repair Warranty will be provided for an additional 9 months subsequent to the initial 90-Day Comprehensive Warranty for a total of 12 months of parts and labor warranty coverage. The unit must be connected and communicating to PoolPak WebSentry for the entire term from start-up in order to qualify.

If qualified, PoolPak will provide or pay for the required part and direct labor only, related to the part replacement. Only the labor required to replace the defective part is under warranty for this 9-month extension. Travel time, diagnostic time, per diems, truck charges, shipping charges etc. are not covered under this Conditional Repair Warranty.

Two-Year Parts Warranty

If any factory installed part supplied by PoolPak fails because of a defect in workmanship or material prior to the completion of the 24th month from date of completion of the warranty activation, PoolPak will provide a new or rebuilt part F.O.B. factory. No labor reimbursement will be made for expenses incurred in replacing the part except as set in the *Initial 90-day Comprehensive or Internet Connected, Conditional One-Year Repair Warranty*.

PoolPak reserves the right to have the defective part returned to the factory in order to determine the warranty applicability. Parts shipping and handling costs (to and from the factory) are not covered outside of the *Initial 90-day Warranty*.

Replacement Part Warranty

If a replacement part provided by PoolPak under this warranty fails due to a material defect prior to the end of the Two-Year Parts Warranty (or the end of the extended warranty period if applicable), whichever comes first, PoolPak will provide a new or rebuilt part F.O.B. factory.

Applicability

This warranty is applicable only to products that are purchased and installed in the United States and Canada. This warranty is NOT applicable to:

1. Products that have become defective or damaged as a result of non-DASV or unauthorized service work, poor maintenance, faulty electrical supply, act of God, or any other circumstances outside of the specified care, maintenance or operation of the equipment including:
 - Components that have been relocated from their original placement as manufactured.
 - Any portion of the system not supplied by PoolPak.
 - Components on which the model and/or serial number plates have been removed or defaced.
 - Components which have become defective or damaged as a result of unauthorized opening of the refrigeration circuit, improper wiring, electrical supply characteristics, poor maintenance, accidents, transportation, misuse, abuse, fire, flood, alteration and/or misapplication of the product.
 - Products not installed, operated and maintained as per the PoolPak Operating and Maintenance Manual.
 - Products operating in mechanical rooms that house chemicals (i.e. chlorine, bromine, water treatment chemicals).
 - Products on which payment is in default.
2. Parts that wear out due to normal usage, such as air filters, fuses and sensors are not covered by this warranty.

NOTE: Refrigerant lost during the *Initial 90-day Comprehensive or Internet Connected, Conditional One-Year Repair Warranty* will be reimbursed in accordance to the current market price of refrigerant at the time of repair and upon discretion of DASV's Customer Support team. PoolPak will not be responsible for refrigerant lost from the system due to improperly installed contractor piping to the remote outdoor air-cooled condenser.

Limitations

1. DASV is a Manufacturer Service organization, not a first-response or urgent response local service company. As such, we highly recommend that equipment owners have a relationship with their own qualified first response service organization or one recommended by DASV.

DASV hours of operation are 8:00 AM to 6:00 PM Eastern, Monday through Friday unless otherwise agreed to under a separate agreement.

Parts replacement can be subject to availability. We highly recommend for mission-critical applications that owners purchase and maintain a local stock of critical components in case immediate replacement be required. If for any reason one of those components is replaced under applicable warranty conditions, PoolPak will reimburse the original cost of any component used under terms of Warranty.

NOTE: PoolPak expressly disclaims any liability for parts replacement delays due to parts unavailability or shipping delays.

2. This warranty is given in lieu of all other warranties. Anything in the warranty notwithstanding, any implied warranties of fitness for particular purpose and merchantability shall be limited to the duration of the warranties described above. PoolPak expressly disclaims and excludes any liability for consequential or incidental damage for breach of any express or implied warranty.

Where a jurisdiction does not allow limitations or exclusions in a warranty, the foregoing limitations and exclusions shall not apply to the extent of the legislation, however, in such case the balance of the above warranty shall remain in full force and effect.

This warranty gives specific legal rights. Other rights may vary according to local legislation.

Force Majeure

PoolPak will not be liable for delay or failure to provide warranty service due to government restrictions or restraints, war, strikes, material shortages, acts of God or other causes beyond PoolPak control.

Optional Extended Warranties

If purchased prior to shipment and documented with a registered extended warranty statement certificate, PoolPak will provide replacement components within the specified period of the extended warranties. Extended warranties commence either upon completion of start-up registration of the equipment or 6 months from factory ship date, whichever comes first, and cover parts replacement only for parts that fail as a result of manufacturing defect. The failed parts must be returned to the factory with transportation prepaid by the customer as a condition of these warranties. Optional extended warranties are for parts only and subject to all the terms of the Two-Year Parts Warranty.

1. Optional Five-Year Compressor Warranty

Subject to the terms above, PoolPak will provide a replacement compressor for up to 60 months from the date of the warranty activation.

2. Optional Five-Year Dehumidifier Coil Warranty

Subject to the terms above, PoolPak will provide a replacement coil for up to 60 months from the date of the warranty activation. Extended coil warranties are for parts of the dehumidifier only and does not cover parts of dry cooler or OACC coils.

3. Optional Ten Year Dehumidifier Coil Warranty

Subject to the terms above, PoolPak will provide a replacement coil for up to 120 months from the date of the warranty activation. Extended coil warranties are for parts of the dehumidifier only and does not cover parts of dry cooler or OACC coils.

4. Optional Five-Year Driveline Warranty

Subject to the terms above, PoolPak will provide driveline replacement parts for up to 60 months from the date of the warranty activation.

Driveline Components Include:

- Supply fan motor
- Exhaust fan motor (including Min Exhaust and Purge Exhaust motors)
- Heat recovery loop pump
- Compressor glycol/water pump
- Dry cooler/outdoor condenser fan(s)
- Dry cooler pump(s)