



NH SERIES DEHUMIDIFIERS

OPERATIONS AND MAINTENANCE MANUAL

SerescoDehumidifiers.com

Contents

General Information	4
Operating Safety (Warnings, Cautions, and Notes).....	4
Reference and Additional Information	5
Contact Us.....	5
Basic Information	6
Dehumidifier View and Options.....	7
Dehumidifier External Systems Connection	8
Dehumidifier Optional Arrangement.....	9
Air Conditioning Options – Outdoor Air Fluid Coolers (OAFC).....	10
Equipment Specific Data	12
Layout and Components	13
Dehumidifier Main Components	13
Layout and Components (continued).....	15
Control System	16
Outdoor Air Fluid Coolers Layout and Components	17
Sequence of Operation	18
Set Points.....	18
Ventilation.....	18
Cooling.....	18
Cooling with Outside Air	18
Cooling with Evaporator coil.....	18
Cooling with Chilled water coil	19
Dehumidification.....	19
Dehumidification with Outside Air	19
Dehumidification with Evaporator coil	19
Purge Mode.....	19
Heat Recovery	19
Space Heating.....	20
Compressor(s) If applicable.	21
Compressor Circuit Operation	21
Outdoor Fluid Cooler Operation	22
Interface and Communication	23

Touch Display Operator Panel	23
Alarms	24
Remote Communication	25
WebSentry.....	25
BMS (Building Management System)	25
Basic Maintenance	26
Maintenance and Safety	26
Maintenance Key Points	26
Routine Maintenance Program	27
Specific Components Maintenance	28
<i>Special Maintenance Tasks. Fluid Cooler Winterization.</i>	28
Pools – Equipment Warranty	30

General Information

This manual provides basic information about the applicable Seresco dehumidifier and its operation.

Important information regarding installation, maintenance, and start up as well as additional and auxiliary systems and devices (outdoor condenser, communication interfaces, etc.) is normally provided with the dehumidifier and can also be obtained from the manufacturer (see **Contact Us** below).

Operating Safety (Warnings, Cautions, and Notes)

FOR YOUR SAFETY: READ BEFORE PERFORMING ANY OPERATIONS, MAINTENANCE OR SERVICE TASKS!



Only qualified technicians should install, operate, maintain or service mechanical equipment including current dehumidification system.

Make sure to read this manual before performing any tasks to familiarize yourself with the equipment as well as with any potential hazards. Always exercise caution!



Beware of electrical power and high electrical voltage!

- Follow proper safety procedures – lockout, tagout, and other respective procedures
- Failure to follow safety procedures can result in serious injury or death



Beware of moving parts and hot surfaces!

- Make sure to stop all moving parts (fans, blowers, etc.) before accessing the equipment's internal space
- Be aware of hot surfaces (hot refrigeration, space heating pipes, coils, heaters, etc.)



Beware of high pressures and chemicals!

- Dehumidifiers, equipped with compressors, contain refrigerant under high pressure; oil is also contained in the compressor and refrigeration circuit(s)
- Some dehumidifiers may also contain other liquids such as glycol mixtures

The following warnings, cautions, and notes appear throughout this manual and referenced documentation whenever special care must be taken to avoid potential hazards that could result in equipment malfunction or damage, personal injury, or death.

WARNING
Indicates a potentially hazardous situation which could result in serious injury or death if handled improperly.

CAUTION
Indicates a potentially hazardous situation which could result in moderate injury or equipment damage if handled improperly.

Note
Indicates a situation that could result in equipment damage or improper/ineffective operation if handled improperly.

Reference and Additional Information

For safe, efficient and problem-free operation, it is critical to handle the dehumidifier (as well as related systems and components) properly at each step - from receiving and storage to installation and start up. Relevant information can be found in the respective documents (like **Installation Manual**) provided with the dehumidifier.

This manual and other related documents could be obtained from the manufacturer (see **Contact Us** below).

Attention: Installation and Service Contractors

 **WARNING!** Any work (installation, start up, service, maintenance, repair, etc.) on any mechanical equipment (dehumidifier, outdoor condenser, fluid cooler, etc.) must be performed in accordance with respective manufacturer's recommendations as well as submittal documentation, local Codes and Regulations, and appropriate field practices. Failure to do so could result in personal injury, equipment damage or malfunction, and will void equipment warranty. Only qualified and properly trained individuals should perform tasks on this equipment.

Attention: Maintenance Team

 **CAUTION.** To ensure equipment longevity and proper and efficient operation, the dehumidifier and its auxiliary systems and devices (outdoor condenser, fluid cooler, etc.) should be maintained properly and regularly. Failure to do so could negatively affect natatorium comfort levels and people's health. It could also lead to equipment damage, malfunction, premature tear and ware and may void equipment warranty.

Contact Us

Seresco

5685 Rue Cypihot,
Saint-Laurent, QC
H4S 1R3

SerescoDehumidifiers.com

1-833-DAS-POOL (327-7665)

Schedule / Modify a Start-up:

Startups@DehumidifiedAirServices.com

Inquire about Warranty:

Warranty@DehumidifiedAirServices.com

Order Parts:

Parts@DehumidifiedAirServices.com

All Other Product Support:

sales@dehumidifiedairservices.com

Basic Information

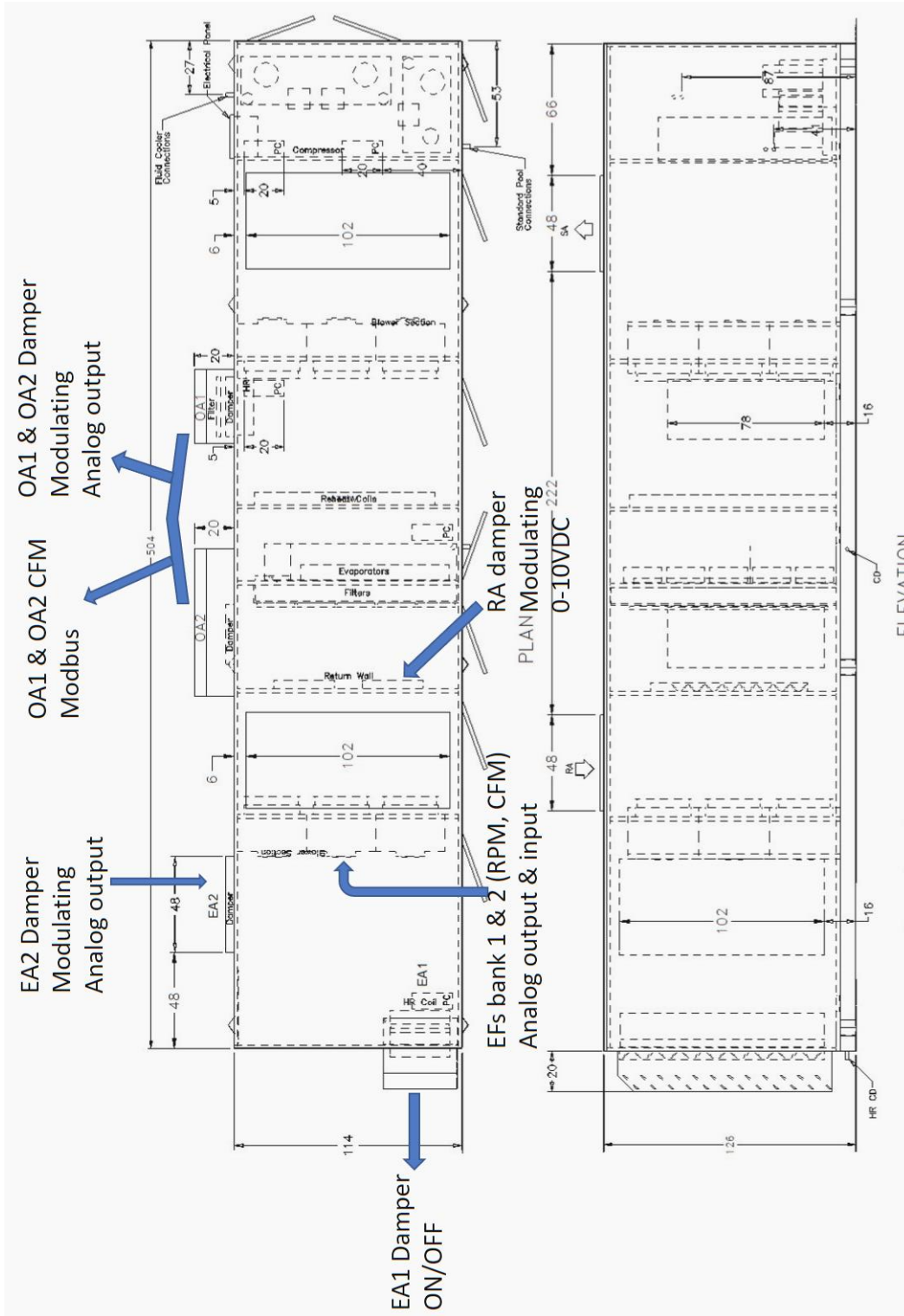

Pic. C.1

Dehumidifier View and Options

Standard NH series dehumidifiers are semi-custom: while basic concept and layout is the same, options and specific systems and components layout and location may vary from one dehumidifier to another. One of the typical dehumidifier arrangement is shown on Pic.C.1.

Dehumidifier Options

- Indoor or outdoor installation.
 - Note: Pic. C.1. shows outdoor model, equipped with louvers (to protect air intake and discharge openings from elements). Indoor model would have ducts connected to respective openings, no louvers would be needed.
- Refrigeration Capacity (compressorless '00' model or cooling capacity in tons) – zero to three compressors (see **Dehumidifier Optional Arrangement** below for more details):
 - Zero-compressor dehumidifier option (6,000 to 64,000 CFM Supply cabinet, models NH000).
 - Two-compressor dehumidifier option (18 to 80 tons, models NH018 to NH080).
 - Three-compressor dehumidifier option (90 to 120 tons, models NH090 to NH120).
- Airflow/ductwork connection *. Pic. C.1 shows some options only; each option location availability depends on the dehumidifier installation (indoor or outdoor) and other options:
 - **Return Air (RA)** ductwork connection - top, bottom, end, sides.
 - **Supply Air (SA)** ductwork connection – top, bottom, sides.
 - **OA1** ductwork connection/termination – top, sides.
 - **EA1** and optional **EA2** ductwork connections/terminations – end, sides.
 - Optional **OA2** ductwork connection/termination - top, sides.
- Optional Space Heating - hot water coil, electric or gas heater **.
- Heat Recovery (HR) circuit.
- Air Conditioning (AC)* – compressorless can have a chilled water coil option; cooling refrigeration has external water cooling or fluid cooler (packaged or separate) options.
 - Note: Pic. C.1 shows outdoor model without a packaged fluid cooler.
 - "Packaged" AC option is available for outdoor models only; alternatively, indoor and outdoor models could be fitted for separate/remote AC option – remote fluid cooler or other external cooling media source.

* *Some available options (tonnage, ductwork connections, AC options etc.) are shown. Refer to the submittal and other relevant documentation for your dehumidifier's options.*

** *For specific details on space heating (hot water, gas, electric) option, refer to the submittal and other documentation:*

Attention! Equipment Clearances and Dimensions!



CAUTION! For equipment proper operation, maintenance and service, respective clearances should be maintained. Generally, 30" clearances to the equipment must be kept for the maintenance and service purposes. For the specific required clearances information, as well as dehumidifier overall dimensions, distances to pipe connections, duct connections etc., refer to the submittal documentation.

Dehumidifier External Systems Connection

Pic. C.1 shows provisions for external systems connections, including ductwork, electric power and various piping connections.

CAUTION! Current manual shows general/default connections' location. For details regarding specific dehumidifier's connections (actual location, piping sizes and position dimensions, circuit type and flow direction etc.), refer to the dehumidifier's submittal documentation as well as dehumidifier's labels and stickers.

- ✓ Except for the condensate, all other piping systems are optional and may not be present in each dehumidifier

- **Condensate Drain Line** – bottom, side (through the dehumidifier base).

NOTE. Dehumidifier MUST be equipped with a P-trap at the condensate connection for proper operation! If dehumidifier is requested from the factory without P-trap, one **MUST** be installed on site prior to dehumidifier being commissioned. Refer to the **Installation Manual** for details.

- **Air Conditioning (AC) Connection.**
 - **Chilled water coil option** – bottom, side.
 - **Packaged AC option** (outdoor dehumidifier with outdoor fluid cooler (O AFC) incorporated with the dehumidifier), does not require piping connection to external AC system or device.
 - *Packaged outdoor models typically have the O AFC mounted at the end of the dehumidifier; alternatively, if requested, O AFC could be mounted on the roof of the dehumidifier.*
 - **Remote ("split") AC option** (indoor or outdoor dehumidifier, connected to external cooled water/glycol system or remote fluid cooler) – side or end (through the compressor compartment wall) connection.
- **Space heating (Hot Water connection)** – bottom, side.
- **Space Heating (Gas Heater connection, gas line).**

 **WARNING! Gas Line.** The gas line must be installed in accordance with respective device documentation (boiler, furnace, etc.) and local codes and regulations.

- **Electric Power and Control Connection.** Typically the power lines are to be brought directly to the main electric panel. However, if applicable the electric power could be brought to the dehumidifier disconnect, which is normally incorporated with main electric panel.

Dehumidifier Optional Arrangement

Multi-Compressor Arrangement and Compressor Compartment Layout

NH series dehumidifier, depending on required capacity, could have two or three compressors. Pic.C.2 shows options of dehumidifier supply air (SA) end and compressor compartment arrangement, based on number of compressors and overall tonnage of the unit.

The end compressor compartment location is used for all tonnages in the NH series.

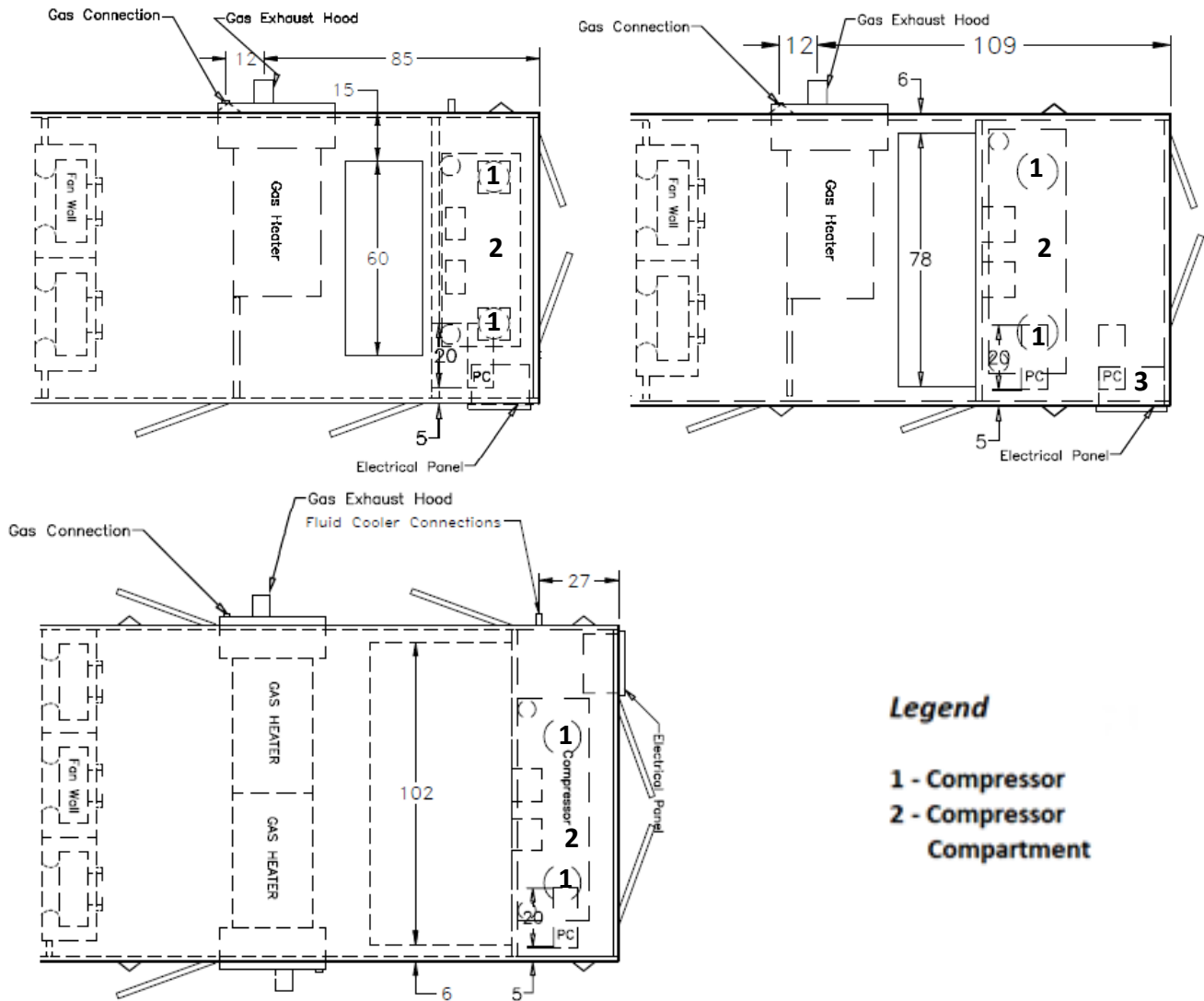

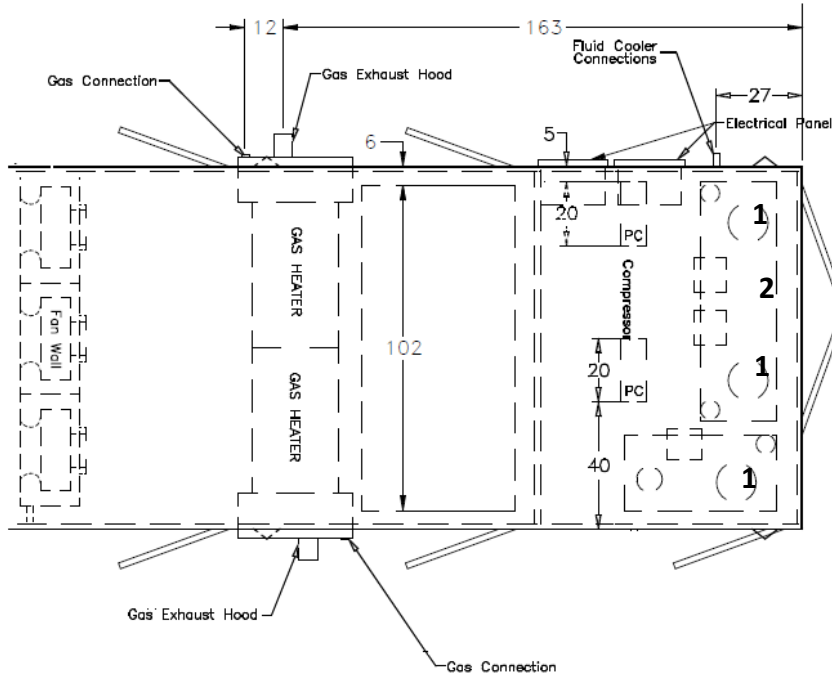

Pic. C.2

Air Conditioning Options – Outdoor Air Fluid Coolers (OAFC).

Basic views of standard air conditioning options are shown on Pic.C.4 (below); standard combinations of the dehumidifier and respective fluid cooler (based on their capacities) are shown in Table C.1. Note, that depending on number of factors, dehumidifier may have different cooler provided with it - refer to the dehumidifier's submittal documentation for more details.

Standard fluid coolers used with this model of dehumidifier is NG-V series, composed of number of “two-coils-two-fans” blocks, based on required capacity of the cooler:

- Fluid Cooler NG-V-22 (Fig.1) composed of two such blocks etc. The largest single fluid cooler, NG-V-62 (Fig.3) composed of six such blocks.

Attention! Equipment Clearances!

Proper clearances should be maintained for adequate airflow and heat rejection! Generally, up to 36" side and 96" top clearances are required. For more information on clearances as well as equipment dimensions and other details, refer to the submittal documentation.

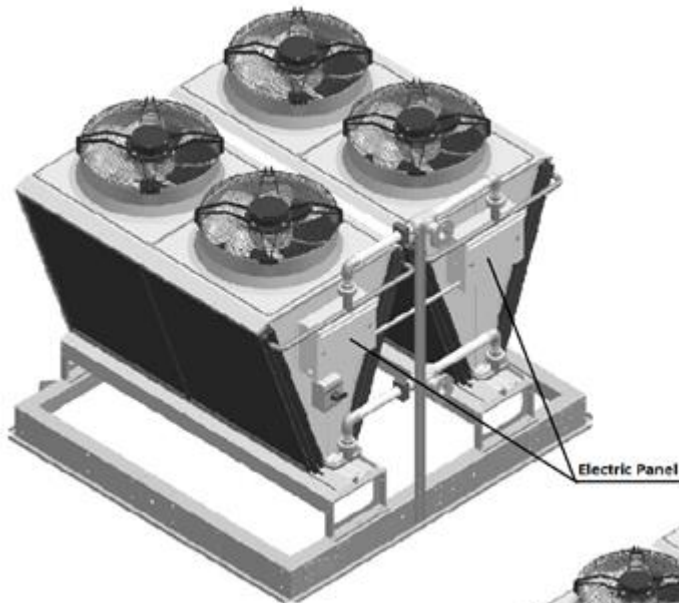

Fig. 1

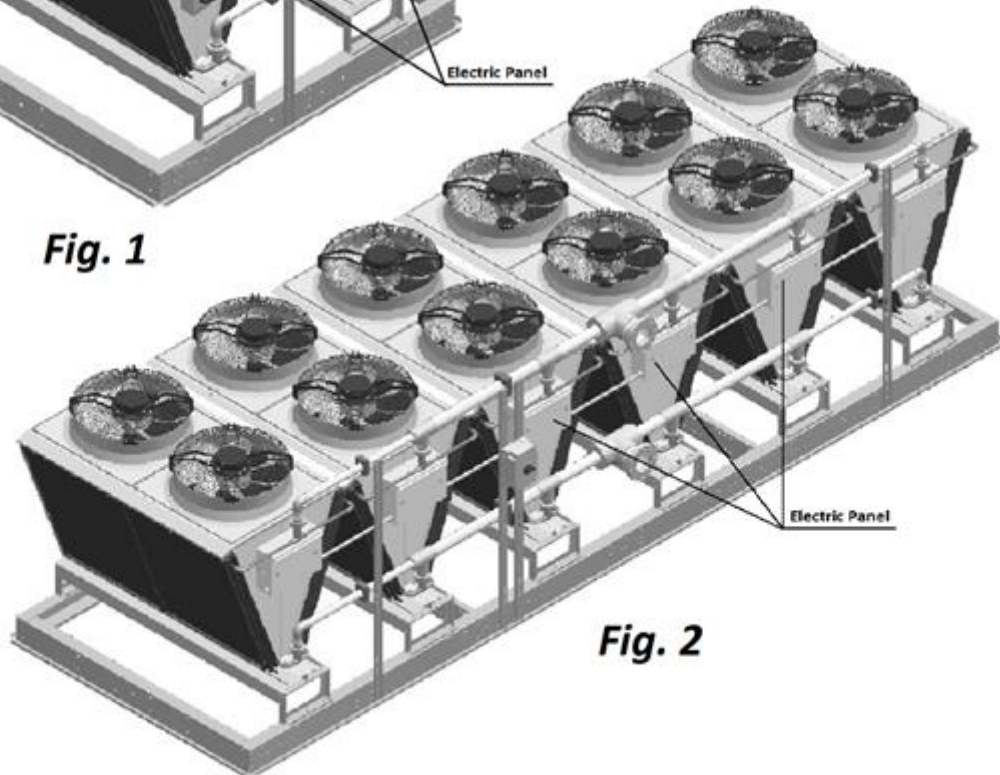

Fig. 2

Pic. C.4

Equipment Specific Data

Specific information for individual dehumidifiers is provided in the following methods:

Main Label (Pic. C.5): the manufacturer tag attached to the front of the dehumidifier includes the dehumidifier's most critical data:

- ✓ General data including:
 - Serial number
 - Dehumidifier model (nomenclature)
 - Design room conditions (air temperature and humidity)
- ✓ Operational data, including:
 - Refrigeration (refrigerant type, charge, etc.)
 - Electrical/airflow (dehumidifier voltage, CFM, etc.)
 - Other applicable data (space/auxiliary heating features, etc.)

Labels and Stickers: attached when applicable to the exterior and interior of the dehumidifier to show:

- ✓ External systems connections location/direction (pool/space heating, cooling circuits, condensate)
- ✓ Air filter locations, quantity, and size.
- ✓ Additional Info (warning, caution stickers, etc.)

Wiring Diagrams: attached to the interior side of the dehumidifier, depict dehumidifier control and power wiring.

General Data				
Serial Number : 16091815				
Unit Model : NE-004-PB-X-P3NB1162G2C4AD3				
Condenser Model : NC-B-1V-CUC-S				
Application : OUTDOOR USE				
Design Room Conditions : 75 °F 54 % R.H.				
Refrigeration Data				
Refrigerant Type : R410A				
Factory Charge (CKT 1) : 21 lbs		Oil Charge (CKT 1) : 11 oz POE		
High Pressure Cutout (Switch) : 600 psig				
Low Pressure Cutout (Switch) : 50 psig				
Electrical & Airflow Data				
MCA (Minimum Wire Size) : 30.0		Use Copper Conductors Only		
MOP (Max Fuse or CKT BKR) : 45.0		System Voltage : 208/3/60		
		<small>(HACR type NEC)</small>		
	Qty	Voltage	CFM	HP
Supply Motor :	1	208/3/60	1600	2.2
Outdoor Air Intake :	-	400	-	-
OACC Blower Motor :	1	208/1/60	-	0.6
Gas Heating Package :	1	-	-	-
	Qty		LRA	RLA
Compressor Motor :	1		123.0	17.6
Pool Heating Data				
Pool Water Flow (Total) : 7.0 GPM		Pressure Drop : 3.0 psi		
Max. Inlet Pressure : 60.0 psi		Connection Size : 0.75 NPT		
Auxiliary Heating Data				
Gas Heater Output : 80 MBH		Gas Connection Size : 0.75 NPT		
Gas Pressure Input (Min/Max) : 7.0 / 14.0 in-H2O				
Boiler Loop Capacity : 7 U.S. Gal. 33% Propylene Glycol				
MADE IN CANADA				

Note: The main label shown above is just an example.

Remotely installed condenser or cooler would have its specific information provided in similar manner (labels etc.).

Attention! Glycol Circuits.

Unless otherwise indicated, equipment fluid circuits (except for refrigeration) such as heat recovery loop, compressor glycol loop, fluid cooler etc., are normally filled/to be filled with water/glycol mixture; normally, rust inhibitor-infused food-grade propylene glycol is used.

Glycol mixture concentration is normally shown on Main Label – refer as needed.

Layout and Components

The general layout and components location is the same for all dehumidifiers of current type, however some may vary, based on the dehumidifier's specific options – refer to submittal documentation. Pic. D.1 below shows most available options, some of which may not be present on your dehumidifier.

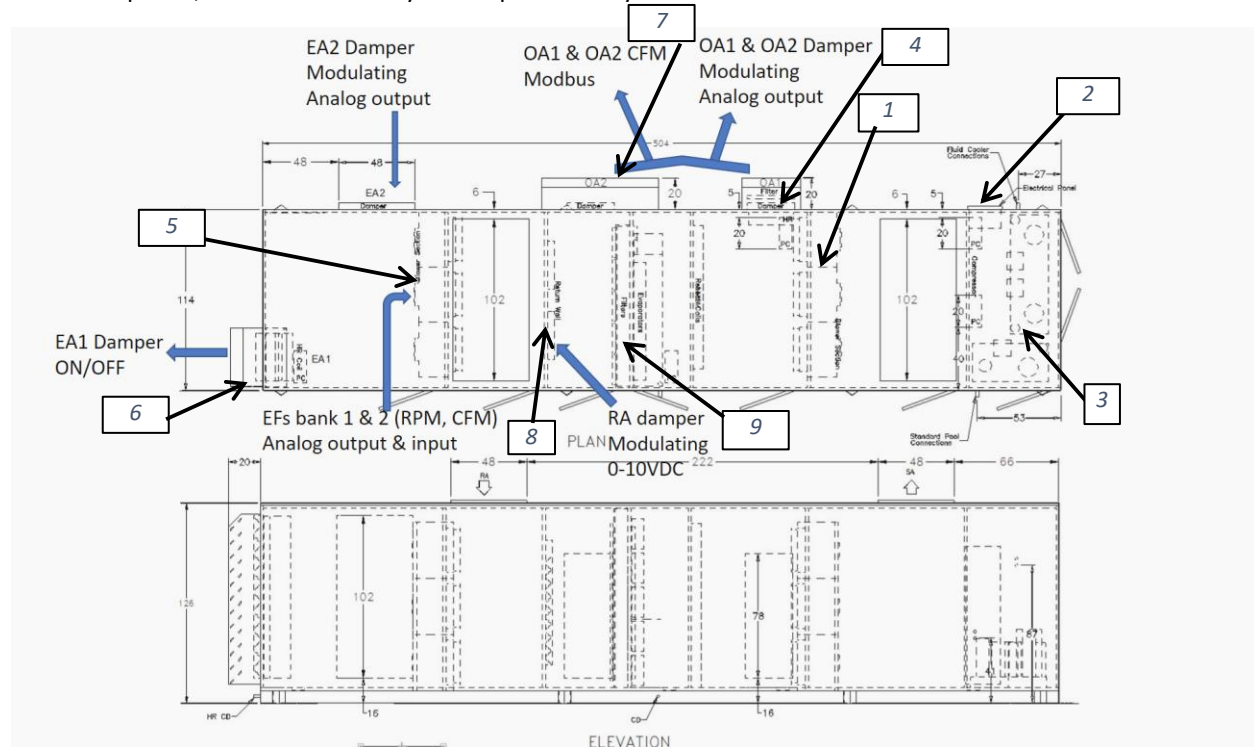

Pic. D.1

Dehumidifier Main Components

- **Main Blower(s) (1)** is a supply fan array located at the supply air end of the unit. Number of blowers may vary based on airflow requirements. Supply fans are mounted within the fan boxes, in the fan wall (see pic D.1A for illustration). Allowing built-in redundancy, a failed fan can temporarily be blanked off to allow continued operation of the unit. Spare blank-off panel is also found in the supply section of the unit.
- **Main Electric Panel (2)** is located at the supply air end of the unit. Either in the compressor vestibule section, if the unit has compressors, or at the supply end of the unit, outside of the airstream in their own dedicated vestibule.
- **Outdoor Air (OA1) Opening (4)** has a motorized damper, HR coil(s) and filter(s). OA1 is also fitted with a modulating actuator for automatic adjustment of outdoor air intake.
 - Outdoor-installed dehumidifier would have a **louver(s)** installed at the OA opening.
 - Indoor-installed dehumidifier would have a **Filter Box(s)** installed at the OA opening.

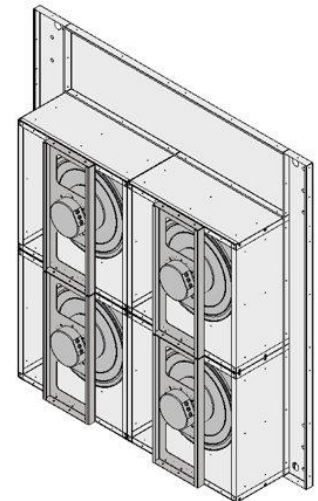

Pic. D.1A

- **Exhaust Fan Blowers** (5) also use fan array which is located on the dehumidifier's return air side. Exhaust Air opening in outdoor-installed dehumidifier is equipped with **louver(s)**. Number of blowers may vary based on airflow requirements. Exhaust fans are mounted within the fan boxes in the fan wall (see pic D.1A for illustration). Allowing built-in redundancy, a failed fan can temporarily be blanked off to allow continued operation of the unit. Spare blank-off panel is also found in the return air section of the unit.
- **Exhaust air opening(s)** EA1 (6) are equipped with HR coils and dampers. All Hybrid units are equipped with HR on the EA1 and OA1 openings, and **HR pump**, installed in the return air compartment.
- **Motorized Return Air (RA) damper** (8) would be located between return air side and OA2 opening(s).
 - Outdoor- installed dehumidifier would have louvers installed at the EA2 opening and OA2 Air openings.
- If dehumidifier is equipped with OA2 (Additional Airflow) option (due to Dehum OA CFM exceeding OA1 max), OA2 equipped with motorized dampers, would be located directly upstream of filter wall.
- If equipped, **Evaporator** coils (7) & **reheat** coil (if applicable) are located directly downstream of the **Main Filter Rack** (9).
 - Motorized **Evaporator Bypass Damper** is located next to the evaporator coils; it by-passes portion of air around evaporator, thus adjusting compressor circuit operation. Some dehumidifiers, based on airflow requirement, could be equipped with additional manual by-pass damper also.
 - Each compressor circuit has its own evaporator coil(s) set (one or two coils per circuit, depending on capacity), while all reheat coils, generally, are manifolded together and serve both compressor circuits together.
- If equipped, Cooling Chilled water coils are located directly downstream of the **Main Filter Rack** (9).
- **Space heater** location, if the dehumidifier is equipped with one, depending on the heater type: **Hot water coil** or **Electric heater** is usually located directly downstream of the **reheat** coil; **Gas heater** (not shown) is usually located downstream of the main blower(s).

Layout and Components (continued)

*If dehumidifier is equipped with compressors: **Compressor Compartment and Main Electric Panel (detailed; see Pic.D.1C).**

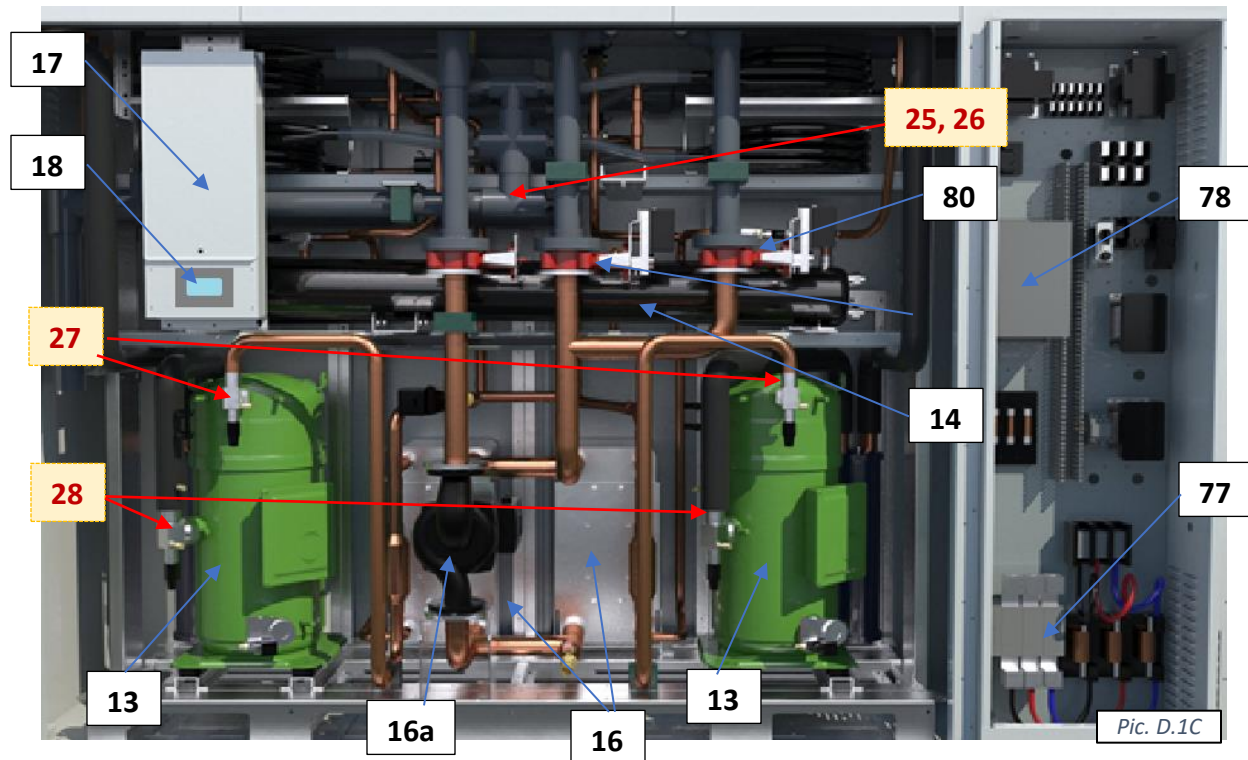

- **Compressor(s) (13), Receiver(s) (14)** and other components are located within the **Compressor Compartment (3)**:
 - Each compressor circuit has glycol-to-refrigerant **plate heat exchanger (16)** and, common to both circuits, **glycol pump (16a)**, that circulates water/glycol to reject compressor-generated heat.
 - Motorized water/glycol **Reheat (79)** and **AC (80) valves'** opening position determines how much fluid is diverted to respective coil(s) (reheat and fluid cooler or external heat sink).
- Control sub-panel with **Main Control Board (17)** and **Operator Panel (18)** is normally mounted on the compressor stand frame.
- **Main Electric Panel (2)** contains main blower(s) **VFD (variable frequency drive)** (if applicable) (78), main **Disconnect (77)**, if one is installed, and other electrical and control components (contactors, fuses, control transformer etc.).
- Packaged **Outdoor Fluid Cooler (19)**, if dehumidifier is equipped with it, is normally mounted at the end of the dehumidifier supply air end (see Pic. D.1D).



Control System

The dehumidifier control system is composed of sensors, spread throughout the dehumidifier, **Main Control Board**, **Operator Panel** and other electric components, located in the **Main Electric Panel**.

Temperature Sensors (Pic. D.2):

- a) **Temperature** sensors (thermistors) are used to monitor various temperatures (air, water, compressor, etc.);
- b) **Combo** sensor is used to monitor air temperature and humidity.

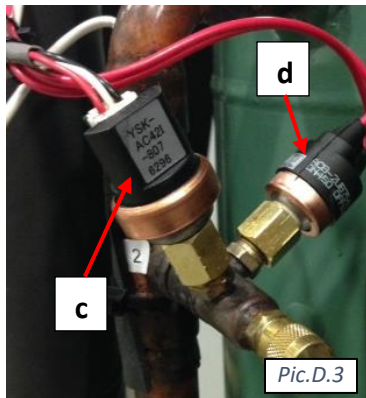

Pic.D.3



Pic. D.2

Compressor operation is monitored with **pressure sensors** (Pic. D.3):

- c) **Pressure Transducers** (as main operational control and safety) and
- d) **Pressure Switches** (fast-reacting backup safety).

Note. Sensors and safeties approximate location is shown on Pic. D.1B and D.1C – refer as needed.

- **RA Combo Sensor** measures temperature and humidity of the pool room air (Return Air) entering the dehumidifier. It is located at the return air ductwork connection to the dehumidifier.
- **OA Combo Sensor** measures temperature and humidity of the Outdoor air (OA1 & OA2 if applicable) entering the dehumidifier; it's located at the OA filter rack.
- **OA Air Velocity Sensor**, Measures incoming OA CFM located in the OA opening.
- **ET (EvapT) Temperature Sensor** measures the temperature of air leaving evaporator coil. It's located directly downstream of the evaporator coil(s) (one sensor per each compressor circuit).
- **Chilled Water Coil Temperature Sensor** measures the temperature of air leaving chilled water coil. It's located directly downstream of the chilled water coil.
- **SA temperature sensor** measures the temperature of the air leaving the dehumidifier (supplied to the natatorium). It must be located downstream of the space heater:
 - SA temperature sensor of dehumidifier, equipped with gas heater, would be composed of four regular temperature sensors, installed in different points at supply duct connection, averaging temperature reading.
- The compressor's discharge line (high pressure side) is equipped with Temperature and Pressure sensors set - **Discharge Temperature Sensor, High Pressure Transducer and High Pressure Switch (27)** - to protect the compressor and control its operation. A similar function is performed by **Suction Temperature Sensor, Low Pressure Transducer and Low Pressure Switch (28)** located at compressor's suction line (low pressure side).
 - Said safeties/sensors are installed on each compressor.
- **Pressure Transducers measure Exhaust CFM(eCFM)** , the **maximum exhaust CFM(mCFM)** is based on the quoted value. When the air velocity exceed what the HR Filter/coil can handle (~600 FPM) the EA2 damper will begin to open. **EA2 Damper modulates from 0-100%**. These pressure transducers ensure a negative pressure is maintained within the natatorium.
- **Having the mandatory Heat Recovery on EA1**, it will also have **Exhaust Air (EA) Temperature Sensor**, installed downstream of exhaust-side located heat recovery glycol coil.

Main Electric Panel, apart from devices listed above (control board, OP, etc.) also contains **Voltage Monitor**; some optional control sensors and devices such as an air pressure differential sensor, current sensor(s). It may also be located in main electrical panel or in the dehumidifier in general.

Outdoor Air Fluid Coolers Layout and Components.

The general layout of AC options is shown on Pic.D.5 below with the outdoor fluid and *NG-V-32* (Fig.2) has been displayed as an example. While layout and main components are similar for all applicable AC options, there are some deviations (number of fans, composition, etc.). Refer to **AC Options Basic View (Basic Information chapter)** for additional information.

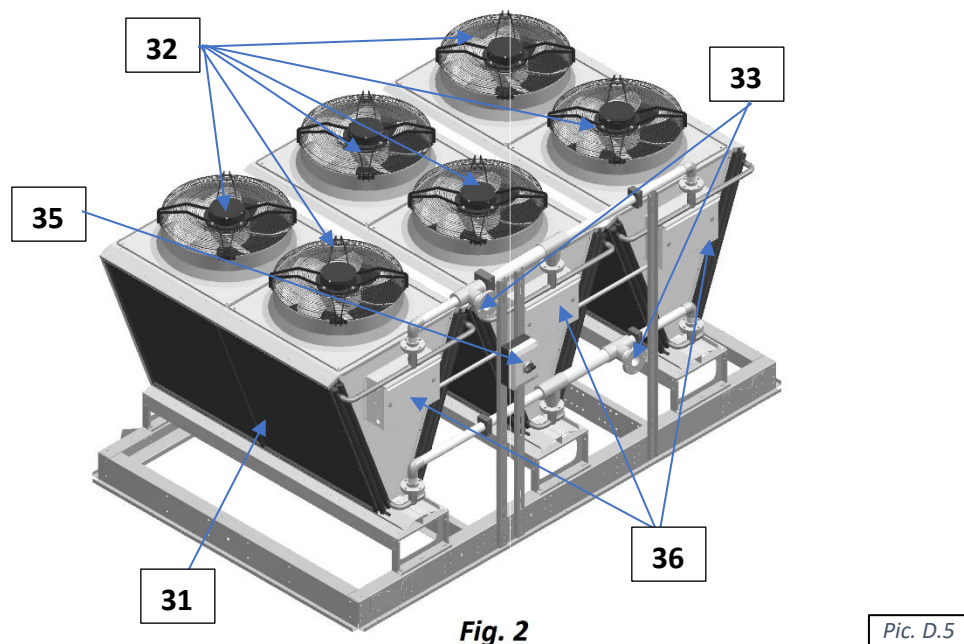

Fig. 2

Pic. D.5

- Cooling (AC) **coils** (31) (where heat from glycol mixture is rejected to the ambient air) is mounted onto metal frame, upstream (before) the **fans** (32), that pulls the air through the coils to absorb the heat.
 - Normally, fluid cooler would have multiple coils and fans. Cooler NG-V-32 (Fig.2), comprised of six coils, mounted on the angle to each other, and six fans, with two fans and two coils presenting a single block. Depending on the capacity, cooler could be comprised of up to six such single blocks, stacked side by side on the same frame and manifolded together.
- Cooler **piping connections** (33) are identified respectively (IN – OUT);
 - Piping connection location may vary – refer to particular cooler labels, stickers, submittal and other documentation.
- Electric power is brought to **disconnect** (35) which feeds it to the **electrical box** (36), that contains cooler power and control apparatuses.
 - Depending on fluid cooler specifics, location of electrical box may slightly differ.

Sequence of Operation

The dehumidifier's ventilation system achieves the pre-set airflow through the dehumidifier. The control system compares air temperature and humidity to their desired values (set points) and proceeds to dehumidify, cool or heat the recirculating air. Outdoor air is used preferentially to dehumidify or cool the natatorium over all other options providing the OA conditions are acceptable.

Set Points

The control system is constantly adjusting unit operation to achieve and maintain pre-defined parameters within couple degrees/percent of the set point. Refer to the dehumidifier's main label for the design value of control parameters, as well as the following note.

Note: To ensure the dehumidifier's most economical operation, we recommend maintaining the following relationship between pool water and room air temperatures:

$$\text{Room Air T} = \text{Pool Water T} + 2^{\circ}\text{F}$$

Ventilation

The **main blowers** run continuously, establishing required CFM. The main blowers speed is pre-set via adjustable variable signal.

Exhaust Air Fan Banks direct a portion of the return air outdoors, through a HR coil & dampered opening EA1, and in higher EA CFMs through the motorized damper EA2. Like the main blowers, exhaust fan(s) speed is also controlled via adjustable (pre-set) variable signal, that varies based on scheduled ventilation mode (Occupied, Non-Occupied and Spectator). Exhaust fan speed is adjusted to ensure a constant pre-set CFM differential between OA & Exhaust Air, this maintains the negative pressure in the natatorium.

OA1 damper, opens to introduce fresh outdoor air into the natatorium. OA1 damper is equipped with modulating-controlled actuator(s).

Cooling

When natatorium air temperature goes over (exceeds) its set point, the dehumidifier control system issues a call for cooling Mode.

Cooling with Outside Air

Sensors responsible for measuring OA1 & OA2 (if applicable), RH and Temperature, feedback the relevant values to the controller. If outdoor air conditions are suitable, it is used preferentially to cool the natatorium over all other options. More OA is brought in if space temperature is not reaching the dead band within the pre-defined setting. The control system does so by increasing exhaust fan(s) speed, with the return air damper being controlled inverse proportionally to the OA dampers.

Cooling with Evaporator coil

If the cooling requirements of the space cannot be satisfied by just the OA, or the OA conditions are unsuitable, and the unit is equipped with compressors, the compressors start to operate enabling the evap coil (in conjunction with OA) to cool space.

Cooling with Chilled water coil

If the cooling requirements of the space cannot be satisfied by just the OA, or the OA conditions are unsuitable, and the unit is equipped with chilled water coils, the valves supplying chilled water to the coils will open and modulate to cool until set points are achieved.

Dehumidification

Respectively, when natatorium air humidity goes over (exceeds) its set point, the dehumidifier control system issues a call for Dehumidification Mode. To execute Dehumidification mode, control system, depending on current conditions, would resort to available means of dehumidification.

Dehumidification with Outside Air

Sensors responsible for measuring OA1 & OA2 (if applicable) CFM, RH and Temperature, feedback the relevant values to the controller. If outdoor air conditions are suitable, it is used preferentially to dehumidify the natatorium over all other options. More OA is brought in if relative humidity is not reaching the dead band within the pre-defined setting. The control system does so by increasing exhaust fan(s) speed, with the return air damper being controlled inverse proportionally to the OA dampers.

Dehumidification with Evaporator coil

If the dehumidification requirements of the space cannot be satisfied by just the OA (OA conditions being unsuitable), the compressors start to operate enabling the evap coil (in conjunction with OA) to dehumidify space.

Purge Mode

Along with **EA1** and **OA1** damper, dehumidifier could have additional **EA dampers** and **OA dampers (EA2 and OA2 respectively)**. EA2 and OA2 damper(s) function is to allow for higher exhaust and fresh air influx.

EA2 and OA2 damper(s) are controlled in the same fashion as **EA1** and **OA1**, and open when the Exhaust CFM requirement surpasses the upper limit for EA1. Dehumidifiers are equipped with additional **Return Air** damper: it closes fully in event of complete air changeover, separating return air side of dehumidifier from supply side (refer to **Layout and Components** chapter, as needed, for respective devices' location).

Purge Mode, triggered manually, ramps up all exhaust fans and OA dampers to their max capacities, until the pre-set time expires or supply air gets too cold. In this mode only fresh air from outdoors is being taken in and air from inside the room is being expelled.

Heat Recovery

Hybrid units, by default have a **Heat Recovery (HR)** closed-loop glycol system, between the EA1 and OA1 dampered openings. Some dehumidifiers may have HR coils on OA2 and EA2 as well, if applicable.

Heat Recovery loop (see Pic. E.1 below) typically consists of two coil banks (air-to-glycol heat exchangers) and a pump, establishing glycol circulation between them. One coil bank, installed at exhaust air opening, recovers portion of exhausted air energy, another coil bank, installed at outdoor air intake, transfers this captured energy to entering outdoor air.

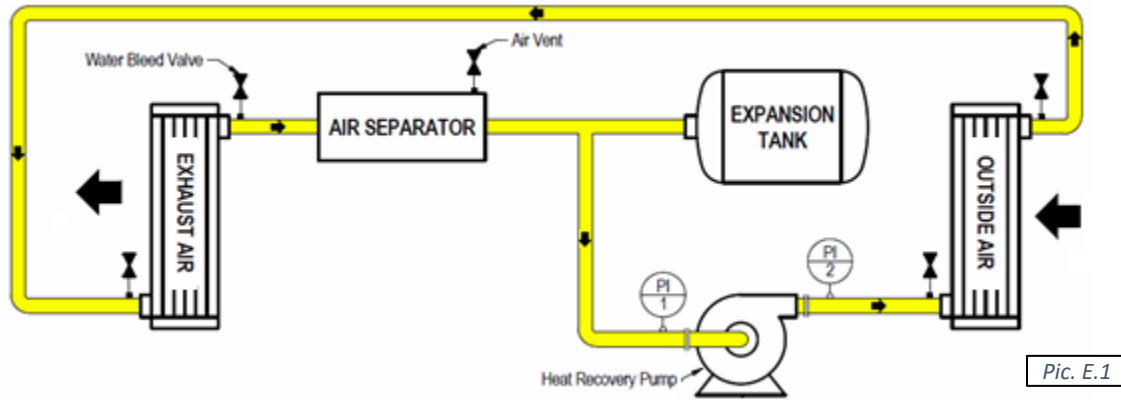

Space Heating

When natatorium air temperature drops below the set point, the dehumidifier control system issues a call for Space Heating Mode and engages space heater (electric heater, hot water coil with valve.) by sending space heating signal, respective to space heater variable control (0-10VDC), etc.

Compressor(s) If applicable.

Whenever the compressor operates, the evaporator is always dehumidifying and cooling the return air. The heat removed from the air at the evaporator as well as the heat from the compressor's action, must be rejected to a hydronic loop, which could be rejected outside or used to reheat the space (optional).

- If room air is needed to be warmed up – more heat is diverted towards reheat coil (if applicable);
- Rest of the heat (if any) is diverted towards external heat sink.

Compressor Circuit Operation

Piping schematic for compressor circuit is shown on Pic. E.2.

- Schematic shows single compressor circuit (second compressor circuit schematic is the same) and common to all compressor circuits' glycol cooling circuit.
- Circuit operation below applies to both compressors; compressors are staged – if first compressor's capacity is not enough to satisfy the call, second compressor will be engaged after certain time delay.

When a demand requires the compressor to operate, the following sequence occurs:

- Once blower operation, related safeties and timers are confirmed by the control system, following occurs:
 - Compressor glycol pump starts, establishing cooling glycol/water flow through the compressor fluid circuit - plate heat exchanger(s) and fluid cooling coils (reheat and/or fluid cooler or external cooling source).
 - Pump down solenoid valve opens and once pressure stabilizes, the compressor starts.
- Based on the natatorium air temperature, the Reheat and AC valves would adjust their opening position (open more/close more), reducing or increasing fluid flow to and through the respective fluid coils:
 - Reheat and AC valves are controlled in the same manner with opposite effect: for example, when AC valve opens 10% more, Reheat valve closes 10% more etc.
 - if more heat is required by the room air, the Reheat valve opens more, and AC valve closes more, thus diverting more fluid to the reheat coils (heat is rejected to the natatorium);
 - if more cooling is required by the room air, the AC valve opens more, and Reheat valve closes more, thus diverting more fluid to the fluid cooler (heat is rejected outdoors).
 - Outdoor fluid cooler fans are engaged only if at least some fluid is diverted towards outdoor fluid cooler and compressor pressure is higher than pre-set level (see **Outdoor Fluid Cooler Operation** below).
- Once demand for the compressor's operation is removed (respective call is satisfied), the pump down solenoid valve closes; once the compressor suction pressure reaches the pre-set pressure, the glycol pump and compressor stop.

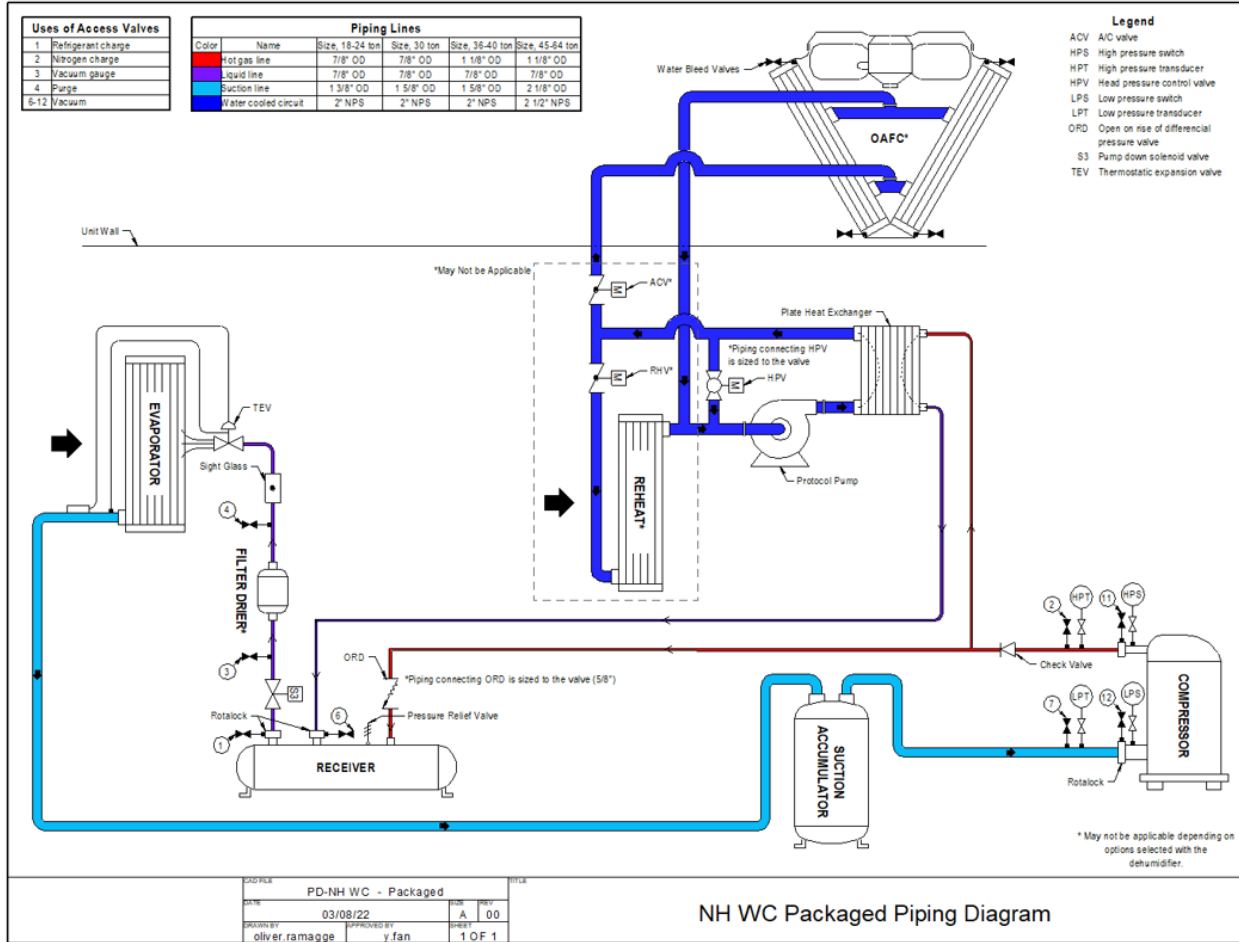

Pic. E.2

Outdoor Fluid Cooler Operation

Based on the type of the outdoor fluid cooler fans' type (EC-type/modulating fans), respective signal(s) are sent by control system to engage said fan(s): EC-type fans - variable 0-10VDC signal (proportional to the compressor head pressure level). Refer to the fans' type and wiring diagram if/when needed.

Interface and Communication

Touch Display Operator Panel

The Touch Display Operator Panel (OP), shown on Pic. F.1, is used as a main interface between the dehumidifier and operator. The same OP can be located in the dehumidifier main electric panel (default; used as a local OP) or installed remotely from the dehumidifier

- **NOTE:** length of CAT5 or CAT6 cable, between remote OP and the dehumidifier MUST NOT exceed 1000'!

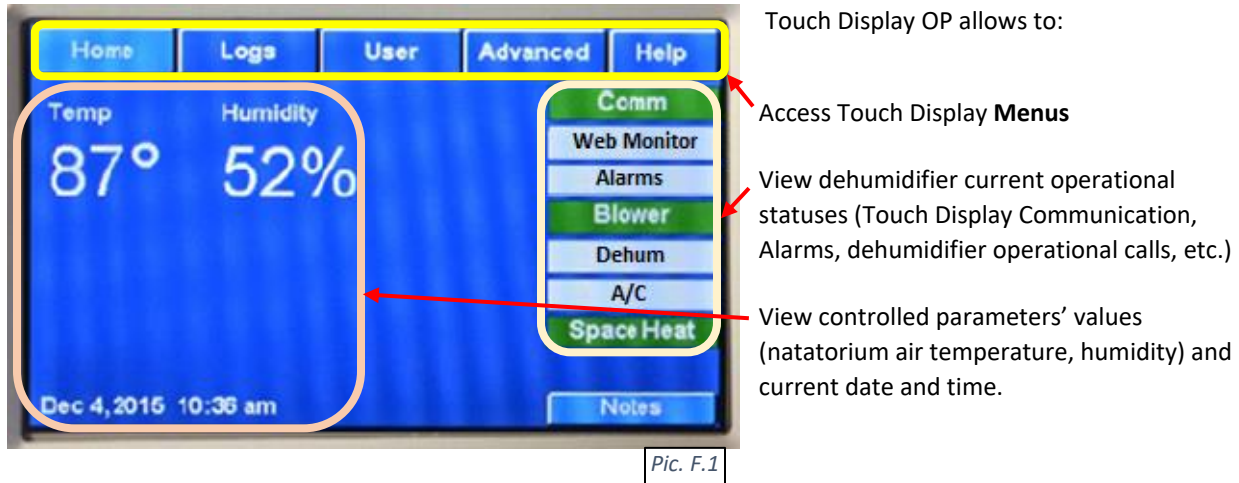

Touch Display Menus:

Home	Opens/returns to the home page
Logs	Access to dehumidifier logs and log-related features (Alarms , etc.)
User	Access to user settings (Setpoints) and commands (Stop/Restart Dehumidifier, etc.)
Advanced	Access to advanced settings and features
Help	Context sensitive help presenting information related to the viewed page

Most common/basic maintenance tasks performed using Touch Display OP

- ✓ **Adjust Setpoint** – in **User** menu: press the **User** button, then press the **Setpoints** button; select desired parameter (room air temperature etc.) and enter the desired value. Press the **Enter** button to confirm the entered value.
- ✓ **Stop/Restart Dehumidifier** — in **User** menu: press the **User** button, then press the **System Restart** button;
 - To stop and restart dehumidifier, press the **System Restart** button
 - To reboot Touch Display OP, press the **Restart Display** button
- ✓ **Review Alarm records** — done via the **Logs** menu: press the **Logs** button, then press the **Alarm Log** button.
- ✓ **Unlock device/dehumidifier, stopped and currently locked out on the alarm** — done via **Logs** menu: press the **Logs** button, then press the **Current Alarms** button; press the **Clear** button next to the respective alarm (the alarm that's locked out the device or entire dehumidifier).

Alarms

If the dehumidifier control system detects abnormal or unsafe for further operation situation, it issues **Alarm** (notification of such situation accompanied by respective component or entire dehumidifier stoppage and/or lockout) or **Alert** (notification of minor abnormal situation without any devices' stoppage or lockout).

All alarms and alerts are recorded and can be viewed/cleared via the Touch Display OP:

- ✓ Viewed: to facilitate troubleshooting and addressing abnormal situation
- ✓ Cleared: to unlock stopped device or entire dehumidifier and allow for further operation

The table F.1 below lists the basic alarms with their descriptions and recommended initial troubleshooting.

Table F.1. Most Common Alarms/Alerts		
Alarm	Alarm Description	Check
No Air	No air flow (air flow switch fault – <i>if air flow switch is installed</i>)	Check main blower operation and air flow switch
Blower OL	Main Blower overload/safety fault	Check main blower operation and its LED light blinking pattern.
Fire	Fire/smoke detector fault – <i>if detector is installed externally and connected to control board</i>	Check external fire/smoke detector/system
Freeze	Supply Air temperature is lower than Freezestat Setting (default: 45 F)	Check SA temperature readout, space heating system operation
Filter	<u>Alert</u> , indicating that filter change timer has lapsed – <i>if timer is activated</i>	Clear the Filter alarm and cancel filter scheduler if not in use.
VM	Voltage Monitor fault – power supply (phasing, voltage etc.) is outside of pre-set limits	Check Voltage Monitor info/status, incoming power (voltage)
Compressor: - HP1-(X) - LP1-(X) - SupHeat1 - DisTemp1	Various compressor-related alarms, relevant to: - Compressor high/discharge pressure; - Compressor low/suction pressure; - Compressor superheat/suction temperature;	Check respective compressor-related data (pressure and temperature readouts), refrigerant level in the receiver's sight glasses, cleanliness of air-side coils and air filters.
HPRelief	<u>Alert</u> , indicating that additional condensing capacity is engaged (pool water heat exchanger etc.) to prevent compressor high pressure from rising too high.	No action required unless it's accompanied by other (compressor-related) alarm or faulty situation.

- ✓ Note that proper and regular maintenance (example: keeping air filters and air-side coils clean) should reduce the chances of abnormal operations, dehumidifier alarm-related stoppages and downtime.



CAUTION! We recommend you have a qualified professional investigate and remedy all reoccurring alarm-related stoppages and lock-outs. Continuous dehumidifier restarting (clearing alarms) without addressing actual issues may result in equipment malfunction, premature wear, and failure.

For more details regarding alarms and alerts, refer to the **Alarms Description** information (available via Help feature in Touch Display OP); contact factory if needed.

Remote Communication

Although dehumidifier is designed to operate as a self-controlled device (not requiring any external control), communication between the dehumidifier and external control and monitoring systems is possible.

WebSentry

WebSentry is an online tool (also referred to as Web Monitor), that allows for remote communication to the dehumidifier for various purposes such as monitoring, data collection, parameters adjustment, and notifications. This feature is included with all dehumidifiers and is useful for maintenance teams and service providers (HVACR technicians).

To establish Web Monitor communication, the dehumidifier must communicate with the factory server via the Internet:

- Connect the dehumidifier to a local network switch, router or wireless AP device (providing connection to a local network):
 - o Plug an Ethernet cable into the sub-board Ethernet RJ-45 jack (sub-board, called Core Module, is located on the main control board in the main electric panel) – see Pic. F.2.
 - **Note:** separate RJ-45 jack (plastic, black) is mounted on the control board directly, for TouchDisplay connection. Make sure to use the proper jack (metal-surface one, located on the sub-board) for Web Monitor connection.
- Configure, as needed, local server and dehumidifier network settings.

BMS (Building Management System)

Communication to BMS can also be supported, depending on the type of communication protocol said BMS utilizes.

The equipment control software supports most common of them

- different control software variation might be required to support different BMS communication protocols. Contact factory if necessary.

BACnet (Internet, IP). Communication is established via the Ethernet cable (same method as Web Monitor).

- ✓ BACnet and Web Monitor communication can be used simultaneously.

BACnet (MS/TP). Communication is established via the RS-485 ports.

LON or **Modbus**. Communication requires external wiring between dehumidifier main control board and BMS terminal. Wiring schematic is normally indicated on wiring diagram (provided with dehumidifier).

- ✓ If dehumidifier is equipped with LON communication option, it's normally provided with pre-wired LonWorks Gateway for communication purposes.

For more information about Web Monitor or BMS communication set up (connection, configuration, access, point cutsheets, etc.) – contact factory.



Web
Monitor
BACnet IP

Touch
Display

Pic. F.2

Basic Maintenance

Although Seresco equipment is built for minimal service downtime, periodic preventative maintenance is required to ensure maximum reliability, safety, and operating efficiency.

 **WARNING!** To ensure equipment longevity and proper and efficient operation, the dehumidifier and its auxiliary systems and devices (fluid cooler, etc.) **must be maintained** properly and regularly. It is recommended to create a **facility-specific Routine Maintenance Program**. Failure to maintain the equipment properly and regularly could result in personal injury, equipment damage or malfunction and will void the equipment warranty.

Maintenance and Safety

Only qualified/properly trained personnel should attempt to perform respective maintenance tasks.

- When it is necessary to work with live electrical components, have a licensed electrician or other qualified professional perform the required task.
- **Be properly trained and equipped.** Some maintenance tasks may involve usage of power tools, chemicals, etc. Refer to such tools and materials data (manuals, Materials Safety Data Sheet [MSDS], etc.). Personnel performing such maintenance tasks should be:
 - Properly trained to handle such tools and materials safely
 - Equipped with proper personal protective equipment
- **Turn the power off.** Before performing any maintenance, disconnect all electrical power, including remote disconnect, and discharge all energy storing devices (VFDs, etc.) before servicing. Follow proper lockout procedures to ensure that power cannot be accidentally restored. Failure to follow provided safety warnings and labels could result in serious injury or death.
- **Be aware of potential hazards.** The equipment contains moving mechanical parts, components under high refrigerant pressures and surfaces with high temperatures. Before entering the dehumidifier and/or performing any equipment maintenance work, make sure that all moving parts are stopped, and it is safe to perform required task.

Maintenance Key Points

Here are some basic/key maintenance considerations, pertinent to all dehumidifiers and their auxiliary systems:

- Dehumidifier in mechanical room. **No chemicals** should be stored **in the same mechanical room** where the dehumidifier is installed. Chemical fumes/off-gas can cause premature deterioration of the equipment.
 - Store chemicals in a separate, well-ventilated room.
- Access to the Equipment. Ensure that the **equipment is accessible** (minimum clearances are maintained): approaches to the dehumidifier are not restricted/limited with materials in mechanical room (indoor installed) or with snow (outdoor installed dehumidifiers and OAFC).
- “MUST DO” maintenance task. Although all other maintenance tasks are as important, these two maintenance tasks are the most common and most helpful:
 - Maintain **clean air filters** (return, outdoor air filters, etc.). Make sure to replace dirty filters regularly.
 - Maintain **clean air-side coils** (especially Fluid Cooler). Make sure to clean coils regularly.
- Pool Water Chemistry. Incorrect pool water chemistry (improper pH level or high concentration of chlorine, sea salt or other corrosive additives etc.) can result in equipment premature wear or malfunction (let alone

poor air quality in the pool and potential health issues) and will void the equipment warranty. Refer to pool water quality standards; contact factory as needed.

Routine Maintenance Program

Creating facility-specific routine maintenance program and following it is vital to equipment longevity and efficient operation.

The suggested general maintenance operations and their frequency/intervals, listed in the table M-1 below, can be used to create such a program. For more detailed maintenance recommendations related to specific components, refer to the respective component manufacturer’s manual.

Table M.1. Recommended Maintenance Tasks and Intervals	
Interval	Maintenance Task
Weekly	Observe the equipment for any changes in running conditions and unusual noise
Quarterly	Clean or replace air filters if clogged or dirty
	Verify that all set-points are correctly programmed as specified by the facility operator
Semi-Annually	Inspect and clean the drain pan(s)
	Tighten electrical connections, if required
	Check and tighten, if required, sensor mounts
	Inspect all airside coils (fluid cooler, dehumidifier coils – evaporator, etc.) for dirt, cobweb build-up, etc.; clean as needed
	Check that the P-trap is primed (filled with water). It is good practice to pour some water into the drain pan to ensure that the P-trap is primed and operational
	Check the outdoor air louvres and dampers for accumulation of dust and clean as required
	Inspect the equipment’s cabinet for corrosion. If any damage is found, clean and repaint the affected surface with a rust-resistant primer
Annually	Clean the fan wheel(s)
	Check dampers operation (linkage/actuator is not loose, damper opens/closes properly etc.)
	Inspect electrical components, wiring and insulation
	Rotate the fan wheel(s) and check for obstructions and rubbing
	Check gasket condition on all doors to ensure an airtight seal
	Check bolts on compressors, motor mounts, dehumidifier bases and coils and tighten if required
	Verify that the airflow around the remote condenser or dry cooler is unobstructed

Specific Components Maintenance

Actual maintenance plan may vary from installation to installation, yet there are several key components from maintenance prospective.

If needed, contact respective component manufacturer for additional maintenance information.

Filters

- Ensure air filters are clean. Dirty air filters will negatively affect dehumidifier performance and lifetime
- Frequency of filters replacement will vary based on air quality, dehumidifier usage, facility type, etc. Make sure to replace filters regularly
- Replace with filters of equivalent size and rating – refer to dehumidifier details (compartment stickers, etc.)

Air-Side Coils

- **Warning: Hazardous chemicals!** Cleaning agents can be highly acidic or alkaline. Handle all chemicals carefully and use appropriate personal protective equipment (PPE). Refer to the cleaning agent manufacturer's Materials Safety Data Sheet (MSDS) for safety and handling information. Failure to follow all safety instructions could result in serious injury or death.
- **Warning: Hazardous pressures!** Coils containing refrigerant under pressure must not be cleaned using a solution over 140 °F. Failure to follow these safety precautions could result in coil bursting, which could result in serious injury or death.

To clean the coil

- Disconnect all electrical power to the equipment
- Use a soft brush to remove loose debris from the coil
- Mix a high-quality coil cleaning detergent with water according to the manufacturer's instructions
- Clean coil according to suggested instructions
- Thoroughly rinse both sides of the coil and the drain pan with, clean water
- Straighten any coil fins that have been bent during the cleaning process
- Confirm the drain line is clear
- Replace all panels and parts and restore electrical power to the equipment

Special Maintenance Tasks. Fluid Cooler Winterization.

Normally fluid coolers are used in the systems, filled with glycol mixture to prevent the system and the fluid cooler from freezing and, potentially, rupturing, when exposed to temperatures below freezing point.

When fluid cooler is used with media that, when exposed to low temperatures, could freeze (water or lower-percentage glycol mixture), one way to protect the equipment is to drain it (also known as “winterization” of the equipment).

Though fluid cooler itself is normally equipped with means to be drained properly/fully, it is recommended to have same means in place for entire system (fluid cooler – piping – dehumidifier etc.):

- Have each local high point of the system equipped with means to bleed the air (air bleeding valve etc.)
- Have each local low point of the system equipped with means to drain the fluid.

 **CAUTION.** Draining and re-filling the fluid cooler must be performed by trained personnel, according to proper field practice and system layout. Improper draining or re-filling the system could lead to equipment damage, malfunction, premature tear and wear and may void equipment warranty.

 **CAUTION.** Ensuring that the fluid cooler and associated system(s) equipped with proper means of draining, creating draining and re-filling procedures as well as determining whether draining is warranted to protect the equipment is outside of manufacturer's scope and is a responsibility of installing contractor and local maintenance team.

Pools – Equipment Warranty

General Policy

All Seresco service and warranty work is managed exclusively by Dehumidified Air Services (DASV). All warranties apply to the original equipment owner and are not transferable. All warranty inquiries should be made to Dehumidified Air Services.

Dehumidified Air Services:

Phone: 1-833-327-7665 Email: Warranty@DehumidifiedAirServices.com

Seresco warrants as set forth and for the time periods shown below that it will provide through either a DASV Service Technician or an authorized service organization specified and approved by DASV, a new or rebuilt part to replace a factory installed part which has failed because of defect in workmanship or material.

NOTE: EVERY REQUEST RELATED TO WARRANTY OF ANY NATURE AS DESCRIBED BELOW MUST BE OFFICIALLY AUTHORIZED AND DOCUMENTED IN ADVANCE BY DASV TO QUALIFY FOR WARRANTY COVERAGE.

Warranty Void Unless Registered

All Warranties are void unless the start-up of the equipment is approved by a DASV service technician. Upon completion of the start-up, a “Warranty Registration Certificate” will be issued, along with the Start-Up Report, which activates the Warranty Period of the equipment. The Warranty Period will commence either upon completion of start-up registration of the equipment or 6 months from factory ship date, whichever comes first.

Initial 90-Day Comprehensive Warranty

During the first 90 days from initial start-up, all parts and repairs related to factory defects or replacement parts are covered by the Seresco manufacturer warranty. All parts and labor requirements will either be handled by DASV technicians directly or managed and approved in advance by DASV through DASV authorized technicians.

Internet Connected, Conditional One Year Repair Warranty

If and only if the equipment is connected to the internet from the date of the warranty activation, a Repair Warranty will be provided for an additional 9 months subsequent to the initial 90-Day Comprehensive Warranty for a total of 12 months of parts and labor warranty coverage. The unit must be connected and communicating to Seresco WebSentry for the entire term from start-up in order to qualify.

If qualified, Seresco will provide or pay for the required part and direct labor only, related to the part replacement. Only the labor required to replace the defective part is under warranty for this 9-month extension. Travel time, diagnostic time, per diems, truck charges, shipping charges etc. are not covered under this Conditional Repair Warranty.

Two-Year Parts Warranty

If any factory installed part supplied by Seresco fails because of a defect in workmanship or material, prior to the completion of the 24th month from date of completion of the warranty activation, Seresco will provide a new or rebuilt part F.O.B. our factory. No labour reimbursement will be made for expenses incurred in replacing the part except as set in the *Initial 90-day Comprehensive or Internet Connected Conditional One-Year Repair Warranty*.

Seresco reserves the right to have the defective part returned to the factory in order to determine the warranty applicability. Parts shipping and handling costs (to and from the factory) are not covered outside of the *Initial 90-day Warranty*.

Replacement Part Warranty

If a replacement part provided by Seresco under this warranty fails due to a material defect prior to the end of the Two-Year Parts Warranty (or the end of the extended warranty period if applicable), whichever comes first, Seresco will provide a new or rebuilt part F.O.B. factory.

Applicability

This warranty is applicable only to products that are purchased and installed in the United States and Canada. This warranty is NOT applicable to:

1. Products that have become defective or damaged as a result of non-DASV or unauthorized service work, poor maintenance, faulty electrical supply, act of God, or any other circumstances outside of the specified care, maintenance or operation of the equipment including:
 - Components that have been relocated from their original placement during manufacturing.
 - Any portion of the system not supplied by Seresco.
 - Components on which the model and/or serial number plates have been removed or defaced.
 - Components which have become defective or damaged as a result of unauthorized opening of the refrigeration circuit, improper wiring, electrical supply characteristics, poor maintenance, accidents, transportation, misuse, abuse, fire, flood, alteration and/or misapplication of the product.
 - Products not installed, operated and maintained as per the Seresco Operating and Maintenance Manual.
 - Products on which payment is in default.
2. Parts that wear out due to normal usage such as; air filters, fuses and sensors are not covered by this warranty.

NOTE: Refrigerant lost during the *Initial 90-day Comprehensive or Internet Connected Conditional One-Year Repair Warranty* will be reimbursed in accordance to the current market price of refrigerant at the time of repair and upon discretion of Customer Support team. Seresco will not be responsible for refrigerant lost from the system due to improperly installed contractor piping to the remote outdoor air-cooled condenser.

Limitations

1. DASV is a Manufacturer Service organization, not a first-response or urgent response local service company. As such, we highly recommend that equipment owners have a relationship with their own qualified first response service organization or one recommended by DASV.

DASV hours of operation are from 8:00 AM to 6:00 PM Monday through Friday, unless otherwise agreed to under a separate agreement.

Parts replacement can be subject to availability. We highly recommend for mission-critical applications that owners purchase and maintain a local stock of critical components in case immediate replacement be required. If for any reason one of those components is replaced under applicable warranty conditions, Seresco will reimburse the original cost of any component used under terms of Warranty.

NOTE: Seresco expressly disclaims any liability for parts replacement delays due to parts unavailability or shipping delays.

2. This warranty is given in lieu of all other warranties. Anything in the warranty notwithstanding, any implied warranties of fitness for particular purpose and merchantability shall be limited to the duration of the warranties described above. Seresco expressly disclaims and excludes any liability for consequential or incidental damage for breach of any express or implied warranty.

Where a jurisdiction does not allow limitations or exclusions in a warranty, the foregoing limitations and exclusions shall not apply to the extent of the legislation, however, in such case the balance of the above warranty shall remain in full force and effect.

This warranty gives specific legal rights. Other rights may vary according to local legislation.

Force Majeure

Seresco will not be liable for delay or failure to provide warranty service due to government restrictions or restraints, war, strikes, material shortages, acts of God or other causes beyond Seresco control.

Optional Extended Warranties

If purchased prior to shipment and documented with a registered extended warranty statement certificate, Seresco will provide replacement components within the specified period of the extended warranties. Extended warranties commence either upon completion of start-up registration of the equipment or 6 months from factory ship date, whichever comes first, and cover parts replacement only for parts that fail as a result of manufacturing defect. The failed parts must be returned to the factory with transportation prepaid by the customer as a condition of these warranties. Optional extended warranties are for parts only and subject to all the terms of the Two-Year Parts Warranty.

1. Optional Five-Year Compressor Warranty

Subject to the terms above, Seresco will provide a replacement compressor for up to 60 months from the date of the warranty activation.

2. Optional Five-Year Dehumidifier Coil Warranty

Subject to the terms above, Seresco will provide a replacement coil for up to 60 months from the date of the warranty activation. Extended coil warranties are for parts of the dehumidifier only and does not cover parts of dry cooler or OACC coils.

3. Optional Ten Year Dehumidifier Coil Warranty

Subject to the terms above, Seresco will provide a replacement coil for up to 120 months from the date of the warranty activation. Extended coil warranties are for parts of the dehumidifier only and does not cover parts of dry cooler or OACC coils.

4. Optional Five-Year Driveline Warranty

Subject to the terms above, Seresco will provide driveline replacement parts for up to 60 months from the date of the warranty activation.

Driveline Components Include:

- Supply fan motor
- Exhaust fan motor (including Min Exhaust and Purge Exhaust motors)
- Heat recovery loop pump
- Compressor glycol/water pump
- Dry cooler/outdoor condenser fan(s)