



# NE SERIES DEHUMIDIFIERS

Compact Outdoor

**OPERATIONS AND MAINTENANCE MANUAL**

[SerescoDehumidifiers.com](http://SerescoDehumidifiers.com)



## Table of Content

<b>General Information</b>	<b>4</b>
• Operating Safety	4
• Reference and Additional Information	5
○ Contact Us	5
• Basic Information	6
○ Dehumidifier View and Options – SLX Cab	6
○ Dehumidifier View and Options – SLBX Cab	8
○ Dehumidifier Optional Arrangement – SLBX Cab	11
○ Air Conditioning Options – Outdoor Air Condensers and Fluid Coolers	12
○ Equipment Specific Data	14
<b>Layout and Components</b>	<b>15</b>
• Dehumidifier Main Components	15
• Control System	17
• Outdoor Air Condensers and Fluid Coolers Layout and Components	19
<b>Sequence of Operation</b>	<b>21</b>
• Set Points	21
• Ventilation	21
○ Purge Option	21
○ Heat Recovery Option	22
• Air Conditioning, Dehumidification and Pool Heating	22
○ Economiser Mode Option	22
○ Compressor(s)	23
• Space Heating	22
<b>Interface and Communication</b>	<b>25</b>
• Touch Display Operator Panel	25
○ Alarms	26
• WebSentry	27
• BMS (Building Management System)	28
• Router Information	29
• Antennae Information	30
<b>Basic Maintenance</b>	<b>31</b>
• Maintenance and Safety	32
• Maintenance Key Points	33
• Routine Maintenance Program	34
• Specific Components Maintenance	35
<b>Chapter W - Warranty</b>	<b>36</b>
• Warranty	37

## General Information

This manual provides basic information about the applicable Seresco dehumidifier and its operation.

Important information regarding installation, maintenance, and start up as well as additional and auxiliary systems and devices (outdoor condenser, communication interfaces, etc.) is normally provided with the dehumidifier and can also be obtained at Seresco (see **Contact Us** below).

## Operating Safety (Warnings, Cautions, and Notes)

### FOR YOUR SAFETY: READ BEFORE PERFORMING ANY OPERATIONS, MAINTENANCE OR SERVICE TASKS!



Only qualified technicians should install, operate, maintain or service mechanical equipment including current dehumidification system.

Make sure to read this manual before performing any tasks to familiarize yourself with the equipment as well as with any potential hazards. Always exercise caution!



#### **Beware of electrical power and high electrical voltage!**

- Follow proper safety procedures – lockout, tagout, and other respective procedures
- Failure to follow safety procedures can result in serious injury or death



#### **Beware of moving parts and hot surfaces!**

- Make sure to stop all moving parts (fans, blowers, etc.) before accessing the equipment's internal space
- Be aware of hot surfaces (hot refrigeration, space heating pipes, coils, heaters, etc.)



#### **Beware of high pressures and chemicals!**

- Dehumidifiers, equipped with compressors, contain refrigerant under high pressure; oil is also contained in the compressor and refrigeration circuit(s)
- Some dehumidifiers may also contain other liquids such as glycol mixtures and pool water

The following warnings, cautions, and notes appear throughout this manual and referenced documentation whenever special care must be taken to avoid potential hazards that could result in equipment malfunction or damage, personal injury, or death.



#### **WARNING**

Indicates a potentially hazardous situation which could result in serious injury or death if handled improperly.



#### **CAUTION**

Indicates a potentially hazardous situation which could result in moderate injury or equipment damage if handled improperly.

#### **Note**

Indicates a situation that could result in equipment damage or improper/ineffective operation if handled improperly.

## Reference and Additional Information

For safe, efficient and problem-free operation, it is critical to handle the dehumidifier (as well as related systems and components) properly at each step - from receiving and storage to installation and start up. Relevant information can be found in the respective documents (like **Installation Manual**) provided with the dehumidifier.

This manual and other related documents could be obtained from the manufacturer (see **Contact Us** below).

### Attention: Installation and Service Contractors

 **WARNING!** Any work (installation, start up, service, maintenance, repair, etc.) on any mechanical equipment (dehumidifier, outdoor condenser, fluid cooler, etc.) must be performed in accordance with respective manufacturer's recommendations as well as submittal documentation, local Codes and Regulations, and appropriate field practices. Failure to do so could result in personal injury, equipment damage or malfunction, and will void equipment warranty. Only qualified and properly trained individuals should perform tasks on this equipment.

### Attention: Maintenance Team

 **CAUTION.** To ensure equipment longevity and proper and efficient operation, the dehumidifier and its auxiliary systems and devices (outdoor condenser, fluid cooler, boiler package, etc.) should be maintained properly and regularly. Failure to do so could negatively affect premise comfort levels and people's health. It could also lead to equipment damage, malfunction, premature tear and ware and may void equipment warranty.

## Contact Us

Seresco  
1071 Ages Drive  
Ottawa, ON K1G 6L3  
Canada  
[SerescoDehumidifiers.com](http://SerescoDehumidifiers.com)

1-833-DAS-POOL (327-7665)

Schedule / Modify a Start-up:

[Startups@DehumidifiedAirServices.com](mailto:Startups@DehumidifiedAirServices.com)

Inquire about Warranty:

[Warranty@DehumidifiedAirServices.com](mailto:Warranty@DehumidifiedAirServices.com)

Order Parts:

[Parts@DehumidifiedAirServices.com](mailto:Parts@DehumidifiedAirServices.com)

All Other Product Support:

[Support@DehumidifiedAirServices.com](mailto:Support@DehumidifiedAirServices.com)

## Basic Information

### Dehumidifier View and Options – SLX Cab

Standard NE004 – NE007 packaged outdoor dehumidifier’s general view and options \* are shown on Pic.C.1.L

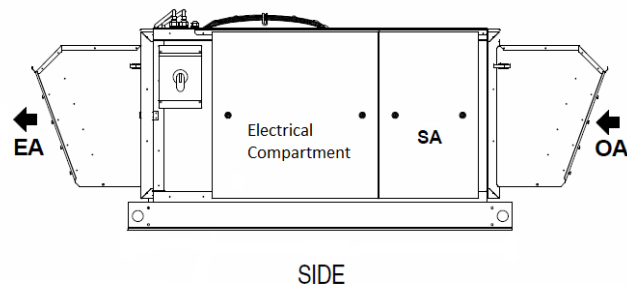
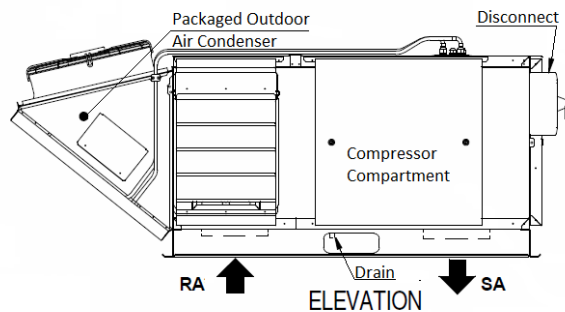
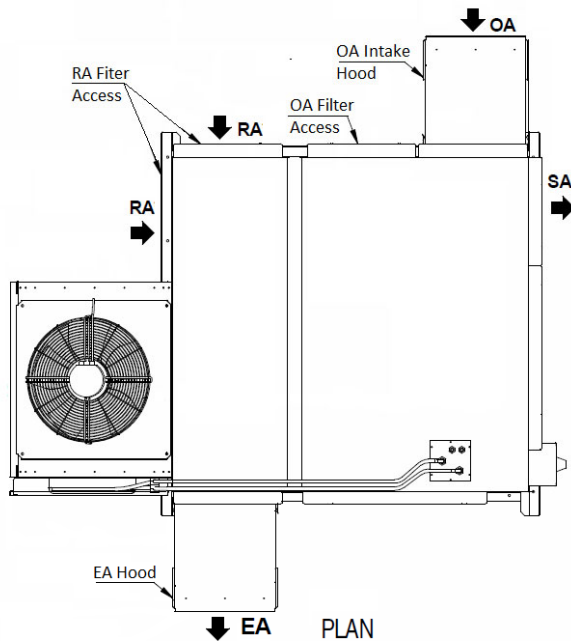

#### Options:

- Return Air (RA) ductwork connection options – bottom, left, horizontal.
- Supply Air (SA) ductwork connection options – bottom, horizontal\*.
- Outdoor Air (OA) intake - horizontal\*.
- Optional Exhaust Air (EA) – horizontal\*.
- Optional **Pool Water Heating** \*\*.
- Optional **Space Heating** - hot water coil, electric or gas heater \*\*\*.
- Packaged **Air Conditioning** (AC) option – built-in Outdoor Air-Cooled Condenser (OACC).\*\*\*\*

Pic. C.1-L

#### Dehumidifier Options – SLX Cab:

- Outdoor, single-compressor dehumidifiers, 4 to 20 ton cooling capacity (apprx.) - models NE004 to NE020\*.

\* All available options for 4-7 ton units (ductwork connections, other options) are shown. Refer to the submittal and other relevant documentation for your equipment options, dimensions etc.

\*\* The pool water heating option relies on compressor-created excess heat and is used as an additional heating source. It does not eliminate the need for a main pool water heater.

\*\*\* For specific details on space heating (hot water, gas, electric) option, refer to the submittal and other documentation:

- **Electric heater or hot water coil**, depending on (capacity, model, size, etc., can be installed externally (fitted in the supply air ductwork) or internally. Refer to your dehumidifier’s submittal documentation
- **Gas-fired heater** can be installed externally (within supply ductwork). Alternatively, the dehumidifier could be provided with **Outdoor Gas Heater package** (dehumidifier with package is shown on Pic. C.2-L below):

\*\*\*\* Built-in (packaged) Outdoor Condenser is standard option, however dehumidifier could be provided with remote AC option as well (remotely installed Outdoor Condenser or Fluid Cooler).

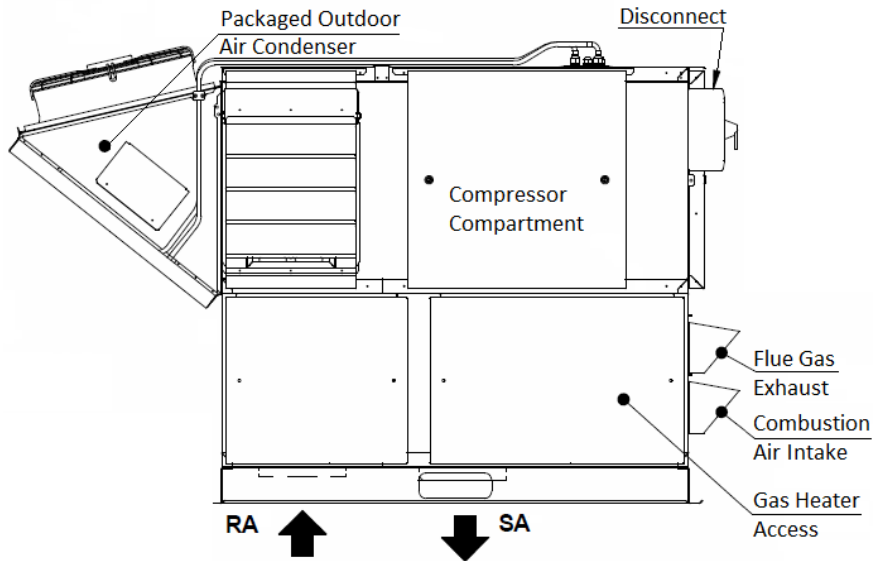

- This configuration somewhat limits the RA and SA options – refer to your dehumidifier submittal.
- Outdoor gas heater package can also accommodate optional **Full Flow Pool Water Heater** – refer to submittal documentation for such option additional details.

Pic. C.2-L

### Attention! Equipment Clearances and Dimensions!



**CAUTION!** For equipment proper operation, maintenance and service, respective clearances should be maintained. Generally, 30" clearances to the equipment must be kept for the maintenance and service purposes. For the specific required clearances information, as well as dehumidifier overall dimensions, distances to pipe connections, duct connections etc., refer to the submittal documentation.

### Dehumidifier External Systems Connection – SLX Cab

Pic. C.1-L shows provisions for external systems connections, including ductwork, electric power and control wires and various piping connections.

**CAUTION!** Current manual shows general/default connections' location. For details regarding specific dehumidifier's connections (actual location, piping sizes and position dimensions, circuit type and flow direction etc.), refer to the dehumidifier's submittal documentation as well as dehumidifier's labels and stickers.

- Except for the condensate, all other piping systems are optional and may not be present in each dehumidifier.

**NOTE.** Dehumidifier **MUST** be equipped with a **P-trap** at the **condensate connection** for proper operation! If dehumidifier is requested/provided from the factory without P-trap, one **MUST** be installed on site prior to dehumidifier being commissioned. Refer to the dehumidifier stickers and **Installation Manual** for details.

- **Electrical Power** to be brought to the dehumidifier disconnect.
- **Pool Heating** and **Space Heating** water connections, as well as **control wiring**, are normally brought through the pipe chase, located in the compressor compartment floor.
- **Remote AC option** (Outdoor Condenser or Fluid Cooler) piping connection: top (same as packaged AC option).
- **Gas line.** If the dehumidifier is equipped with a gas heater package for space heating purposes, the **gas** line connection is to be brought to the gas heater directly.



**WARNING! Gas Line.** The gas line must be installed in accordance with respective device documentation (boiler, furnace, etc.) and local codes and regulations.

## Dehumidifier View and Options – SLBX Cab

Seresco standard NE008 to NE016 dehumidifier general views as well as some options are shown on Pic.C.1-B.

- Pic. C.1-B shows only one example of dehumidifier arrangement – refer to submittal documentation for specific details.

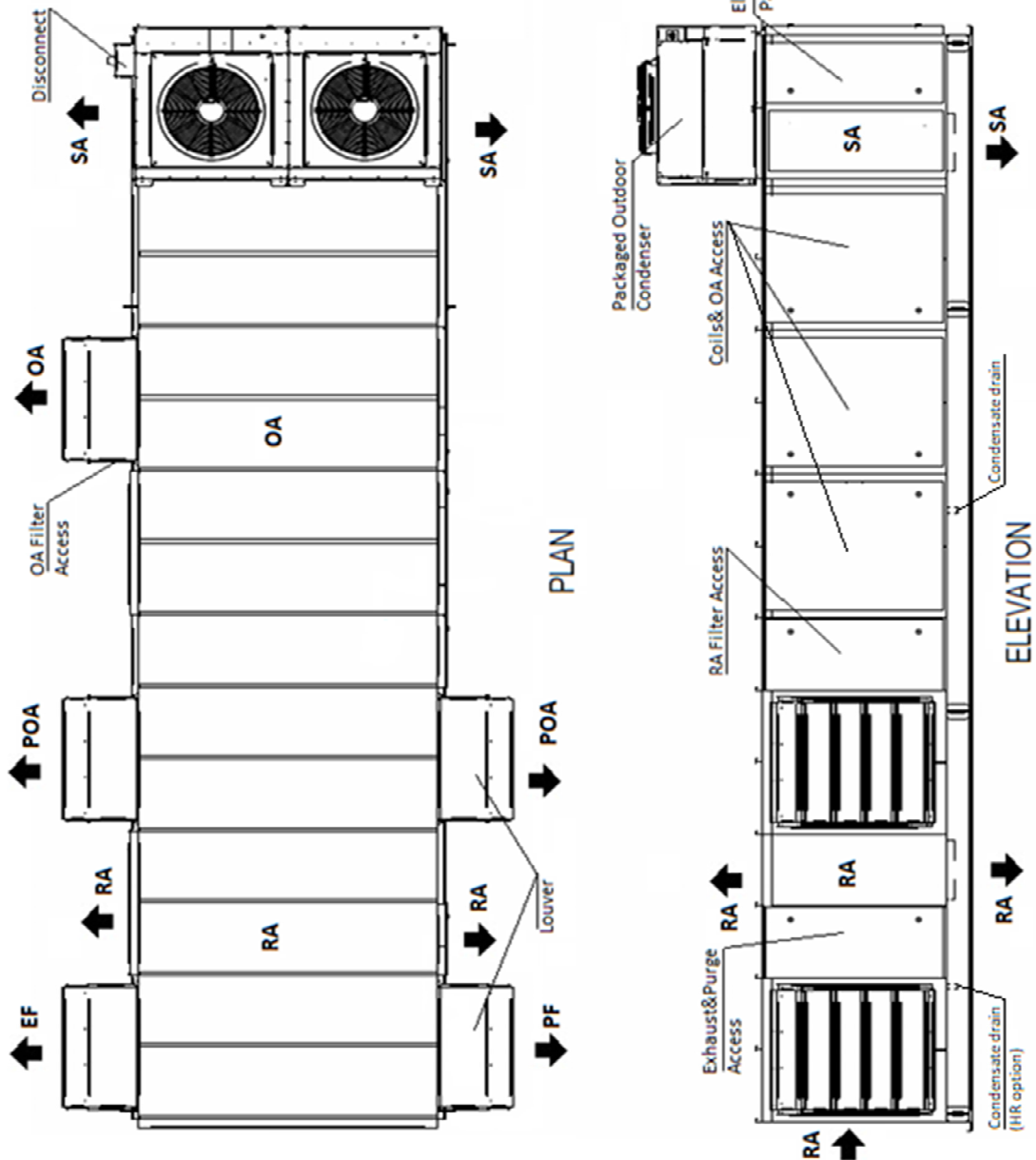

Pic. C.1-B



### Dehumidifier Options – SLBX Cab

- Indoor or outdoor installation.
  - Pic. C.1-B. shows outdoor model, equipped with louvers (to protect air intake and discharge openings from elements). Indoor model would have ducts connected to respective openings, no louvers would be needed.
- Single-compressor dehumidifiers 8 to 16 ton cooling capacity (apprx.), models NE-008 to NE-016\*.
  - Two-compressor dehumidifier option (see **Dehumidifier Optional Arrangement** below for details):
    - 16 to 32 ton capacity (apprx.) - models NE-216 to NE-232;
    - 8 to 20 ton capacity (apprx.) – models NE-D08 to NE-D20.
  - Lower compressor capacity (NE004 to NE007 models) is normally provided in different cabinet arrangement; however, to accommodate additional ventilation and other options (like Purge, Heat Recovery etc. – see below), not available with smaller cabinets, dehumidifier of smaller compressor capacity could be provided in current cabinet also.
- Airflow/ductwork connection options \* - as shown on Pic. C.1 and described below (some option locations availability depends on the dehumidifier installation – indoor or outdoor):
  - **Return Air (RA)** ductwork connection - top, bottom, end, sides.
  - **Supply Air (SA)** ductwork connection – top, bottom, sides.
  - Optional **Min Outdoor Air (OA)** ductwork connection/termination – top, sides.
  - Optional **Min Exhaust Fan (EF)** and **Purge Fan (PF)** ductwork connections/terminations – end, sides.
  - Optional **Purge Outdoor Air (POA)** ductwork connection/termination - top, sides.
- Optional **Pool Water Heating** \*\*.
- Optional **Space Heating** - hot water coil, electric or gas heater \*\*\*.
- Optional **Heat Recovery** (HR) circuit.
- **Air Conditioning (AC)**\* – external water cooling, outdoor condenser or fluid cooler.

\* All available options (tonnage, ductwork connections, AC options etc.) are shown. Refer to the submittal and other relevant documentation for your dehumidifier's options.

\*\* The pool water heating option relies on compressor-created excess heat and is used as an additional heating source. It does not eliminate the need for a main pool water heater.

\*\*\* For specific details on space heating (hot water, gas, electric) option, refer to the submittal and other documentation:

- **Gas-fired duct heater** can be installed internally (fitted inside the dehumidifier at the factory) or provided for field installation (to be fitted in the supply air ductwork).
- **Electric heater** or **hot water coil**, depending on capacity, model, size, etc., can be installed externally (mounted on the top of SA opening or fitted in the supply air ductwork) or internally. Refer to your dehumidifier's submittal documentation.

### Attention! Equipment Clearances and Dimensions!



**CAUTION!** For equipment proper operation, maintenance and service, respective clearances should be maintained. Generally, 30" clearances to the equipment must be kept for the maintenance and service purposes. For the specific required clearances information, as well as dehumidifier overall dimensions, distances to pipe connections, duct connections etc., refer to the submittal documentation.

## Dehumidifier External Systems Connection

Pic. C.1-B shows provisions for external systems connections, including ductwork, electric power and control wires and various piping connections.

**CAUTION!** Current manual shows general/default connections' location. For details regarding specific dehumidifier's connections (actual location, piping sizes and position dimensions, circuit type and flow direction etc.), refer to the dehumidifier's submittal documentation as well as dehumidifier's labels and stickers.

- ✓ Except for the condensate, all other piping systems are optional and may not be present in each dehumidifier

- **Condensate Drain Line** – bottom, side (through the dehumidifier base).

**NOTE.** Dehumidifier **MUST** be equipped with a P-trap at the condensate connection for proper operation! If dehumidifier is requested from the factory without P-trap, one **MUST** be installed on site prior to dehumidifier being commissioned. Refer to the **Installation Manual** for details.

- **Air Conditioning (AC) Connection.**
  - **Packaged AC option** (outdoor dehumidifier with outdoor air condenser (OACC) incorporated with the dehumidifier) does not require piping connection to external AC system or device.
    - *Pic 1.C. shows packaged outdoor model with OACC mounted on the roof; alternatively, OACC could be mounted at the end of the dehumidifier.*
  - **Remote ("split") AC option** (indoor or outdoor dehumidifier, connected to external cooled water/glycol system or remote fluid cooler or outdoor air condenser) – top (through the compressor stand roof) connection.
    - Normally, the dehumidifier has only one AC option – air-cooled (requiring connection to the outdoor air condenser) or water-cooled (requiring connection to the fluid cooler or other external water-cooled system such as geothermal, cooling tower, etc.). Therefore, only one of these options present with the actual dehumidifier.
- **Pool Water Heating** – bottom, side.
- **Space heating (Hot Water connection)** – bottom, side.
  - Some connection location options for both, pool and space, heating pipe lines, are limited to indoor installation only – refer to submittal documentation
- **Space Heating (Gas Heater connection, gas line).** If the dehumidifier is equipped with a gas heater (boiler, gas furnace etc.) for space heating purposes, the **gas** line connection is to be brought to the gas heater directly.

 **WARNING! Gas Line.** The gas line must be installed in accordance with respective device documentation (boiler, furnace, etc.) and local codes and regulations.

- **Electric Power and Control Connection.** Electric power is normally brought to the dehumidifier disconnect (see Pic. C.1). If dehumidifier is not equipped with it, power lines to be brought directly to the main electric panel. Also, provisions are made to bring control and communication connections through the dehumidifier roof at the compressor compartment

## Dehumidifier Optional Arrangement – SLBX Cab

### Two-Compressor Arrangement

Standard NE series dehumidifier has one compressor, however two-compressor arrangement is available also. Note, that all options and details, provided above, apply to both, standard and two-compressor arrangement:

- **Single Deck** dehumidifier has same dimensions, features and options as standard single-compressor one, except for two compressor/refrigeration circuits instead of one.
- **“Double-Decker”** dehumidifier is shown on Pic. C.3. It is composed of two identical dehumidifiers, one installed on top of another and controlled as a single dehumidifier (each deck is equipped with one compressor/refrigeration circuit).

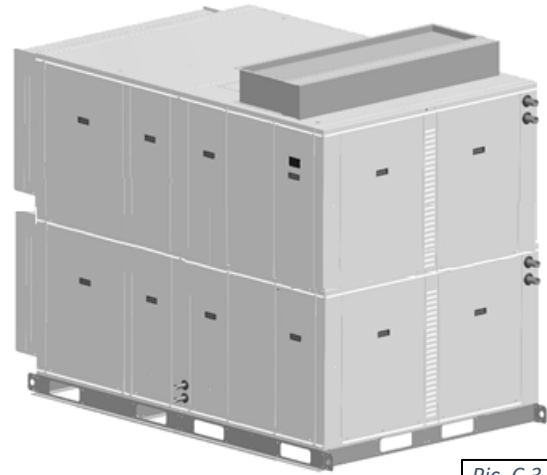

Pic. C.3

### Single and Two-Compressor Arrangement – Dehumidifier Model

Dehumidifier typical arrangement, total capacity, and number of compressors are reflected in its model (for specific dehumidifier model refer to its Main Label – see **Specific Data Info** below), as illustrated in examples below:

- **NE008** – single-deck single-compressor dehumidifier.

Two -compressor NE series dehumidifier:

- **NED08** - single-deck two-compressor dehumidifier (single deck equipped with two compressors);
- **NE216** - double-deck two-compressor dehumidifier (composed of two identical dehumidifiers NE008).

Most often, “Double-Decker” comes as two horizontal dehumidifiers, one “stacked” on the top of another, however it could also be composed of two dehumidifiers (horizontal OR vertical) installed side by side or separately, still being controlled as one.

### Air Conditioning Options - Outdoor Air Condensers (OACC) and Fluid Coolers (O AFC).

Packaged AC option is also standard for this type of dehumidifier. Basic views of remote air condition options are shown below on Pic.C.4-A (condensers, NC models) and Pic. C.4-B (coolers, NG models); standard combinations of the dehumidifier and respective air conditioning option (based on their capacities) are shown in Table C.1.

\* Table C.1 shows standard dehumidifier and condenser/cooler combination; depending on number of factors, dehumidifier may have different condenser/cooler provided with it - refer to the dehumidifier’s submittal documentation for more details.

\*\* Two-compressor dehumidifier would normally have paired-up two outdoor condensers of respective size (one per compressor).

*For example, NE216 would have double-condenser, composed of two NC-Z-1 (see Pic.C.4, Fig.1).*

\*\*\* The pump package is optional - the fluid cooler may be provided without it.

Table C.1. Dehumidifier-AC Combination*		
Dehumidifier – Outdoor Condenser**		Fig.#
NE004	NC-B	1
NE005 – NE008	NC-Z-1	2
NE010 – NE016	NC-Z-2	3
Dehumidifier – Fluid Cooler***		Fig.#
NE004 – NE007	NG-V-0	5
NE008 – NE012, NE208 – NE212	NG-V-11	6
NE014 – NE016, NE214 - NE224	NG-V-12	7
NE228 – NE232	NG-V-22	8

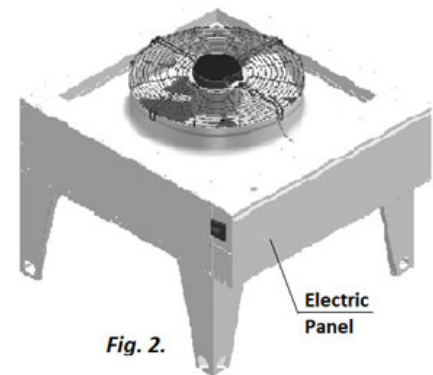
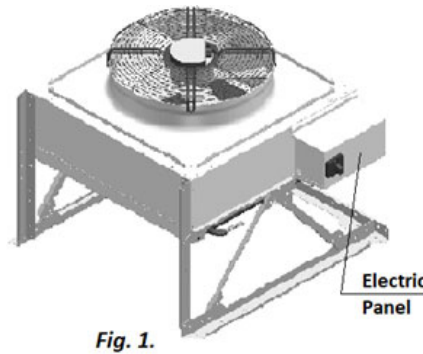

Pic. C.4-A

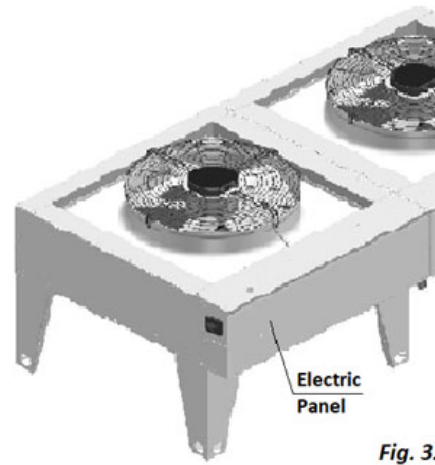

#### Attention! Equipment Clearances!

Proper clearances should be maintained for adequate airflow and heat rejection! Generally, up to 36” side and 96” top clearances are required. For more information on clearances as well as equipment dimensions and other details, refer to the submittal documentation.

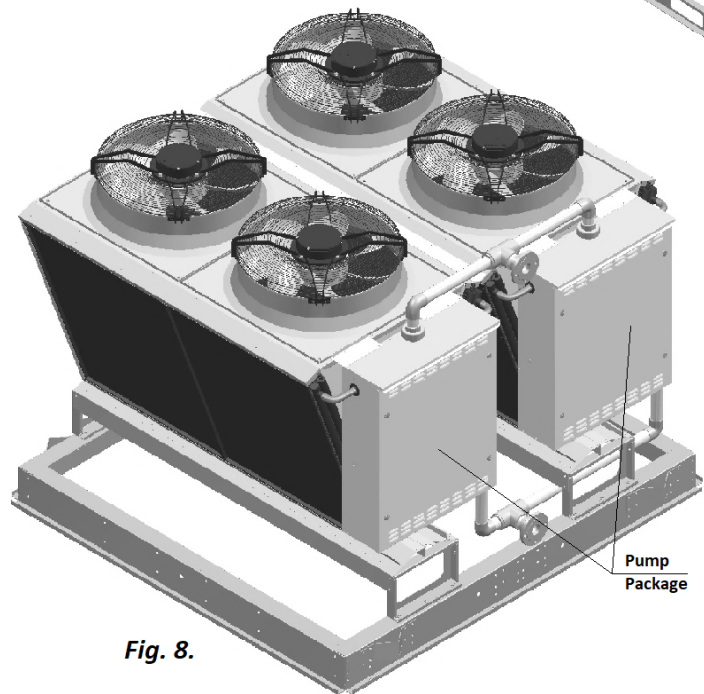
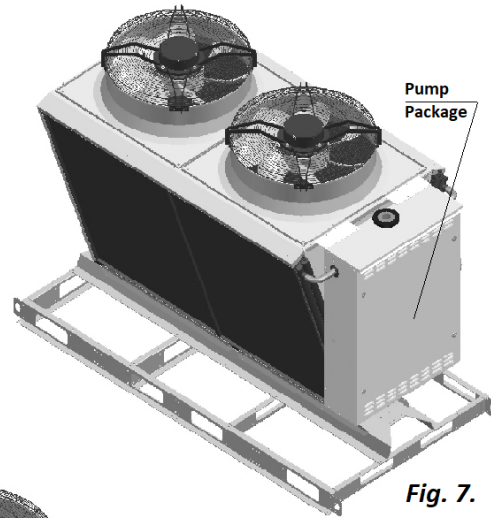
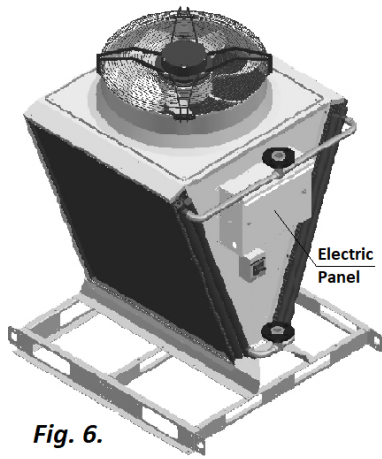
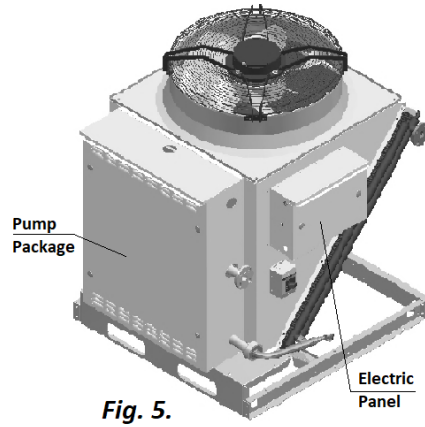
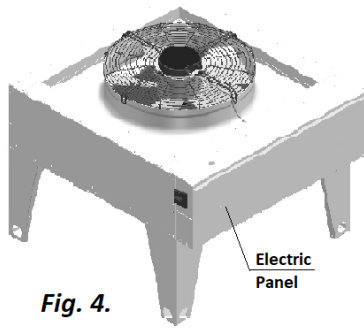

Pic. C.4-B

## Equipment Specific Data

Specific information for individual dehumidifiers is provided in the following methods:

**Main Label** (Pic. C.5): the manufacturer tag attached to the front of the dehumidifier includes the dehumidifier's most critical data:

- ✓ General data including:
  - Serial number
  - Dehumidifier model (nomenclature)
  - Design room conditions (air temperature and humidity)
- ✓ Operational data, including:
  - Refrigeration (refrigerant type, charge, etc.)
  - Electrical/airflow (dehumidifier voltage, CFM, etc.)
  - Other applicable data (pool heating, space/auxiliary heating features, etc.)

**Labels and Stickers:** attached when applicable to the exterior and interior of the dehumidifier to show:

- ✓ External systems connections location/direction (pool/space heating, cooling circuits, condensate)
- ✓ Air filter locations, quantity, and size.
- ✓ Additional Info (warning, caution stickers, etc.)

**Wiring Diagrams:** attached to the interior side of the dehumidifier, depict dehumidifier control and power wiring.

Remotely installed condenser or cooler would have its specific information provided in similar manner (labels etc.).

seresco		Advanced Dehumidifiers WebSentry® Technology			
<b>General Data</b>					
Serial Number : 16091815					
Unit Model : NE-004-PB-X-P3NB1162G2C4AD3					
Condenser Model : NC-B-1V-CUC-S					
Application : OUTDOOR USE					
Design Room Conditions : 75 °F 54 % R.H.					
<b>Refrigeration Data</b>					
Refrigerant Type : R410A					
Factory Charge (CKT 1) : 21 lbs		Oil Charge (CKT 1) : 11 oz POE			
High Pressure Cutout (Switch) : 600 psig					
Low Pressure Cutout (Switch) : 50 psig					
<b>Electrical &amp; Airflow Data</b>					
MCA (Minimum Wire Size) : 30.0		Use Copper Conductors Only			
MOP (Max Fuse or CKT BKR) : 45.0		System Voltage : 208/3/60			
<small>(NACR type NEC)</small>					
	Qty	Voltage	CFM	HP	FLA
Supply Motor :	1	208/3/60	1600	2.2	5.0
Outdoor Air Intake :	-		400	-	-
OACC Blower Motor :	1	208/1/60	-	0.6	2.6
Gas Heating Package :	1		-	-	-
	Qty			LRA	RLA
Compressor Motor :	1			123.0	17.6
<b>Pool Heating Data</b>					
Pool Water Flow (Total) : 7.0 GPM		Pressure Drop : 3.0 psi			
Max. Inlet Pressure : 60.0 psi		Connection Size : 0.75 NPT			
<b>Auxiliary Heating Data</b>					
Gas Heater Output : 80 MBH		Gas Connection Size : 0.75 NPT			
Gas Pressure Input (Min/Max) : 7.0 / 14.0 in-H2O					
Boiler Loop Capacity : 7 U.S. Gal. 33% Propylene Glycol					
Seresco Technologies Inc. www.serescodehumidifiers.com					
MADE IN CANADA					

Pic. C.5

**Note:** The main label shown above is just an example.

### Attention! Glycol Circuits.

Unless otherwise indicated, equipment fluid circuits (except for refrigeration and pool water circuits) such as heat recovery loop, compressor glycol loop, boiler package, fluid cooler etc., are normally filled/to be filled with water/glycol mixture; normally, rust inhibitor-infused food-grade propylene glycol is used.

Glycol mixture concentration is normally shown on Main Label – refer as needed.

## Layout and Components

The general layout and components location is the same for all dehumidifiers of current type, however some may vary, based on the dehumidifier's specific options – refer to submittal documentation. Pic. D.1 below shows all/most available options, some of which may not be present on your dehumidifier (A: SLX cab 4-7 tons, B: SLBX cab 8-20 tons).

### Dehumidifier Main Components

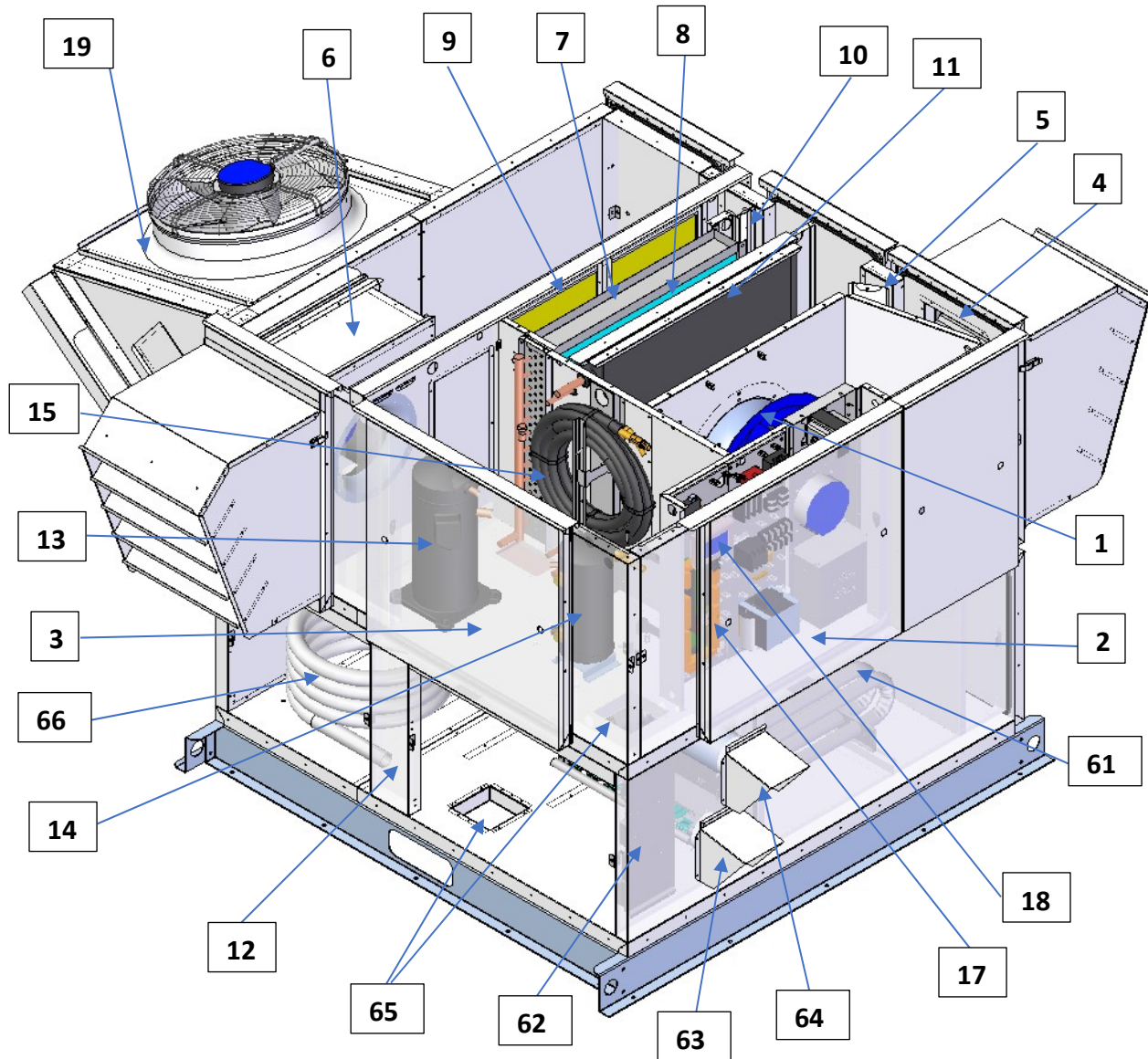

Pic. D.1-A

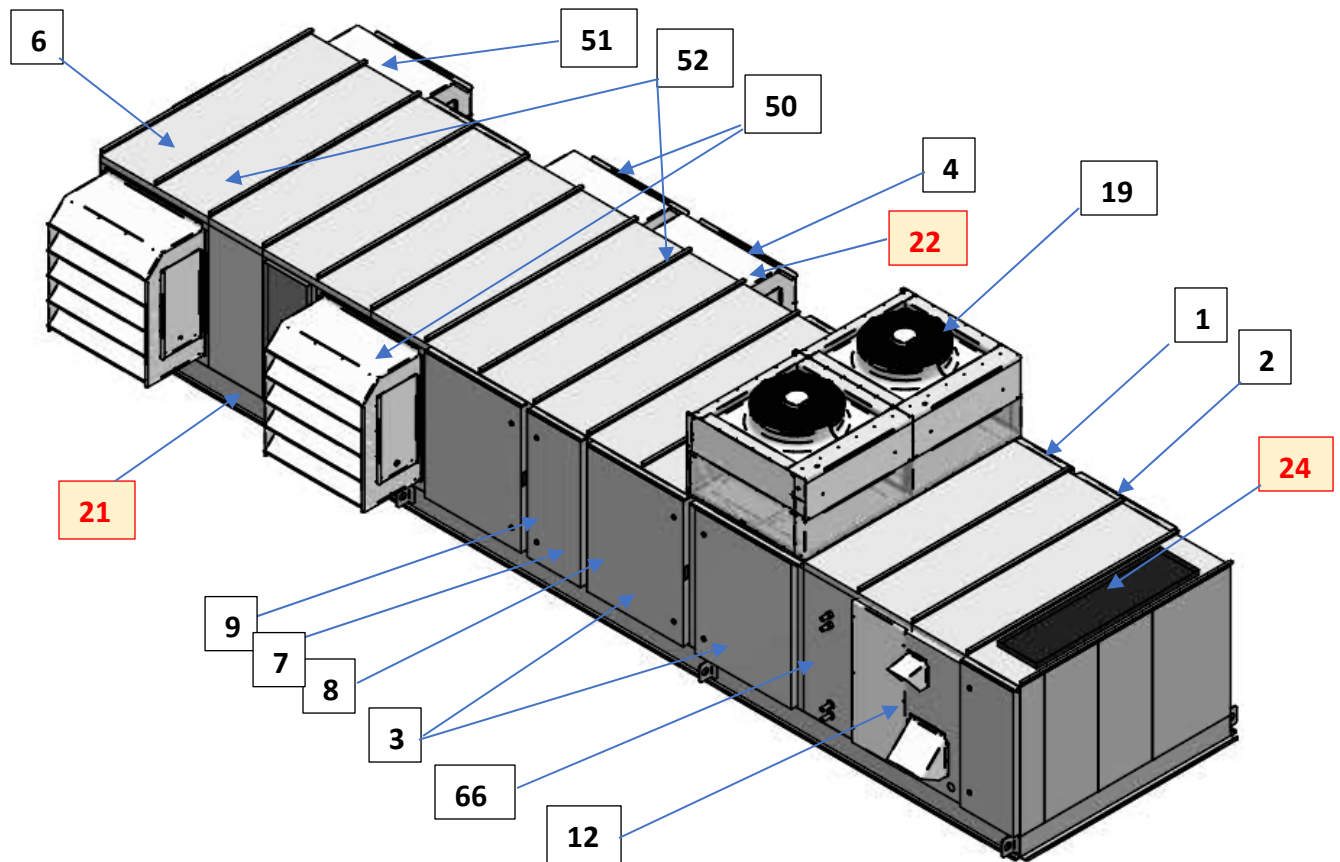

Pic. D.1-B

- **Main Blower (1)** is in the main blower compartment next to the **Main Electric Panel (2)** and **Compressor Compartment (3)**.
- **Min Outdoor Air (OA) Opening (4)** is equipped with a louver and, as an option, with a motorized damper and filter(s). The **Manual OA Damper (5)** is usually used to set proper amount of outdoor air intake.
- **Purge Outdoor Air (POA) Openings (50)** are equipped with a louver and a motorized damper for economizer/purge operation whether exhaust or purge is mounted integral or remote.
- **Exhaust Fan Assembly (6)** (fan and motorized damper) is located on the dehumidifier's return air side opposite to the OA intake; Exhaust Air (EA) opening is equipped with a louver also. **Purge Exhaust Fan Assembly (51)** can also be found here and this opening is also equipped with a louver.
  - If necessary, EA and OA louvers can be removed for shipping, service or maintenance; removing EA louver also allows the Exhaust Fan assembly to be slid out from the dehumidifier.
- **Heat Recovery Package (52)** includes glycol coils on min OA and min EA airflows. If option is included, service access is through the RA compartment and includes glycol pump, piping and all necessary accessories.
- Refrigeration coils - **Evaporator (7)** and **Reheat (internal condenser) (8)** - are located directly downstream of the **Main Filter Rack (9)**.
  - **Evaporator Bypass Damper (10)**, is located next to the evaporator coil. It helps to control compressor suction pressure by adjusting the amount of air, bypassing the evaporator.
- **Space Heater (11)** – hot water coil or electric heater (depending on the dehumidifier's option) –It's located directly downstream of the **Reheat** coil.
  - Optional **Gas Heater Package (12)**, is normally installed under the dehumidifier. It includes gas heater (61), gas heater **electric and control panel (62)** and provisions for **combustion air intake (63)** and **flue exhaust (64)**.



- **Pipe chase opening** (65) in Compressor Compartment and Gas Heater Package floors allow for external systems connections (pool and space heating, control etc.).
- **Compressor** (13), **Receiver** (14) and other components are located within the **Compressor Compartment**.
  - If the dehumidifier has the **standard pool water heating option**, the compressor circuit includes the **coaxial pool water heat exchanger** (15) and refrigeration pool valve.
  - **Full Flow Pool Water Heat Exchanger** (66) (optionally available with **Gas Heater Package** box only) would be located within the package, replacing standard **Coaxial Pool Water Heat Exchanger** (15).
  - If the dehumidifier has the **water-cooled** air conditioning option (equipped with remote fluid cooler or connected to external water-cooling source), the compressor circuit would also include the **plate heat exchanger**, that would be located in compressor compartment.
- **Main Electric Panel** contains **Main Control Board** (17), **Operator Panel** (18) and other electrical components.
- Packaged **Outdoor Air-Cooled Condenser** (19) is normally mounted on the dehumidifier side for SLX cabinet and mounted on top or end for larger SLBX models.

## Control System

The dehumidifier control system is composed of sensors, spread throughout the dehumidifier, **Main Control Board**, **Operator Panel** and other electric components, located in the **Main Electric Panel**.

**Temperature Sensors** (Pic. D.2):

- a) **Temperature** sensors (thermistors) are used to monitor various temperatures (air, water, compressor, etc.);
- b) **Combo** sensor is used to monitor air temperature and humidity.



Compressor operation is monitored with **pressure sensors** (Pic. D.3):

- c) **Pressure Transducers** (as main operational control and safety) and
- d) **Pressure Switches** (fast-reacting backup safety).

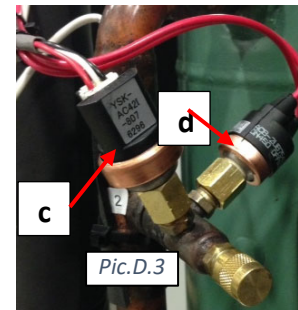

Sensors and safeties approximate location is shown on Pic. D.4.

- **RA Combo Sensor** (21) measures temperature and humidity of the pool room air (Return Air) entering the dehumidifier. It is located at the main filter rack.
- **OA Temperature Sensor** (22) measures outdoor air temperature; it's located at the OA filter rack.
  - As an option, the combo sensor (instead of regular thermistor) can be installed at the OA intake to measure both the temperature and humidity of the outdoor air.
- **ET (EvapT) Temperature Sensor** (23) measures the temperature of air leaving evaporator coil. It's located directly downstream of the evaporator.
- **SA Temperature Sensor** (24) measures temperature of air leaving dehumidifier (supplied to the premise); it's located in the main blower compartment at the supply air duct connection.
- If the dehumidifier is equipped with the pool heating option, **Pool Water Temperature Sensors (Pool In** (25) and **Pool Out** (26)) measure entering and leaving pool water temperature, respectively. The sensors are located directly at the respective connections of the coaxial pool water heat exchanger.
  - If Full Flow Pool Heating option is present, respective pool water sensors are located at full flow pool water heater inlet and outlet, respectively (with optional water flow sensor).
- The compressor's discharge line (high pressure side) is equipped with Temperature and Pressure sensors set - **Discharge Temperature Sensor, High Pressure Transducer and High Pressure Switch** (27) - to protect the

compressor and control its operation. A similar function is performed by **Suction Temperature, Low Pressure Transducer and Switch (28)** located at compressor's suction line (low pressure side).

- **Main Electric Panel**, apart from devices listed above (control board, OP, etc.) also contains **Voltage Monitor**; some optional control sensors and devices such as an air pressure differential sensor, current sensor(s). It may also be located in main electrical panel or in the dehumidifier in general.

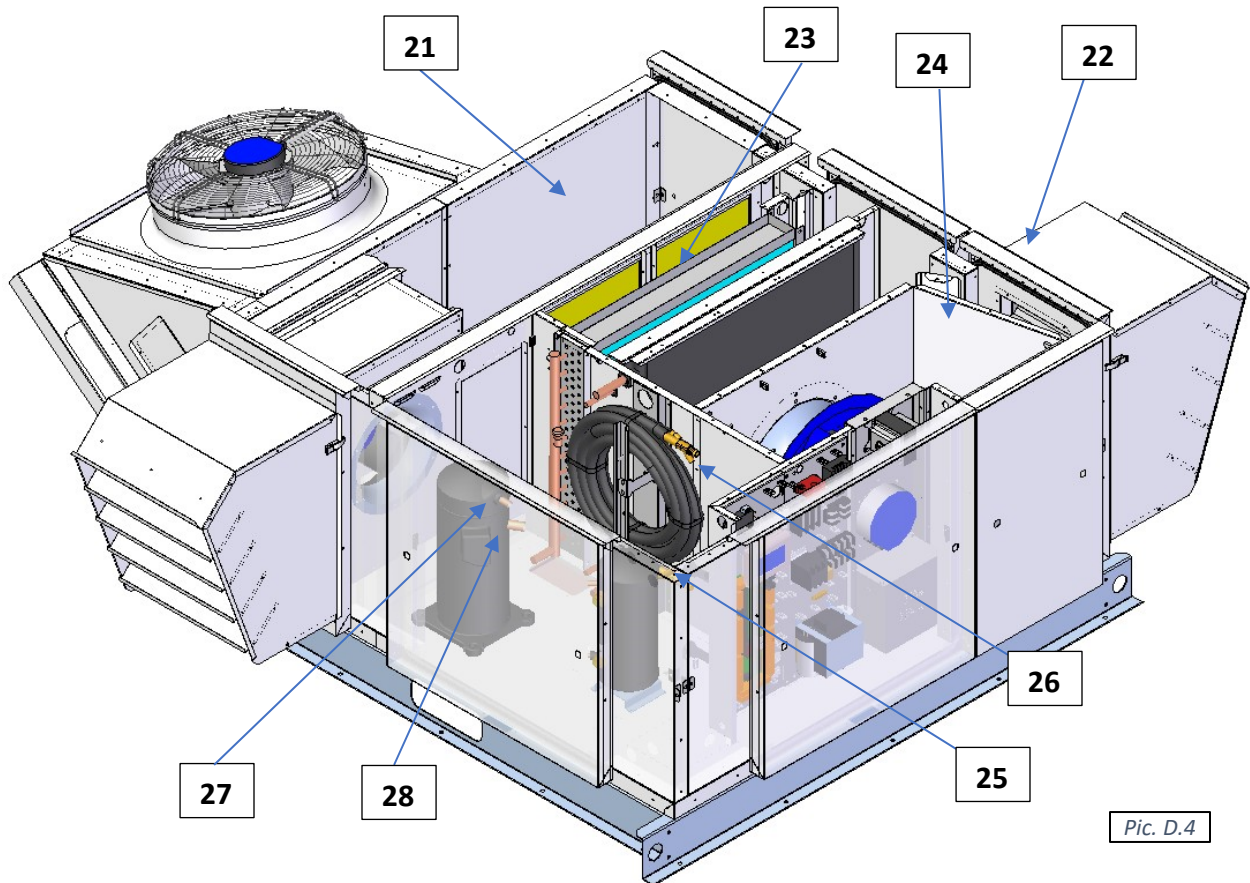

## Outdoor Air Condensers and Fluid Coolers Layout and Components.

The general layout of remote AC options (air-and water-cooled) is shown on Pic.D.5 below with the outdoor air condenser NC-B-1 (left) and fluid cooler NG-V-0 (right) as an example. While layout and main components are similar for all applicable AC options, there are some deviations (number of fans, coil sizes, composition, etc.). Refer to **AC Options Basic View** (**Basic Information** chapter) for additional information.

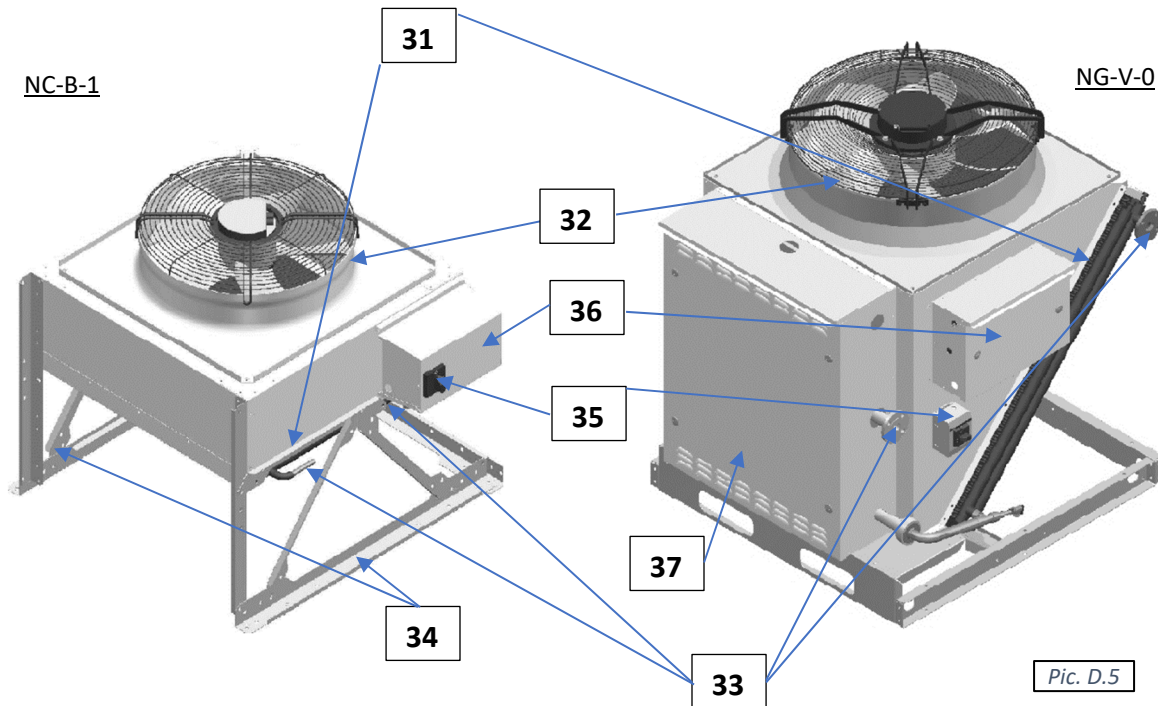

- Cooling (AC) **coil** (31) (where heat from refrigerant in the outdoor condenser or glycol mixture in fluid cooler is rejected to the ambient air) is mounted onto metal frame/air box upstream (before) the **fan** (32), that pulls the air through the coil to absorb the heat.
  - Condenser/cooler **pipng connections** (33) are identified respectively (IN – OUT, Hot gas – Liquid etc.). Piping connection location may vary – refer to cooler/condenser labels, stickers, submittal and other documentation.
  - Depending on the type, size and installation, outdoor condensers may be provided with different set of **legs/supports** (34), which are required assembly on-site – refer to the Installation manual.
  - Depending on the size and capacity, condenser or cooler may have multiple fans or coils.
- Electric power is normally to be brought to **disconnect** (35) (if cooler/condenser is equipped with such), which feeds it to the **electrical box** (36), that contains condenser or cooler power and control apparatuses.
  - Depending on type of fluid cooler, location of electrical box may slightly differ.

**Fluid Coolers Pump Package.**

**Fluid Coolers**, if equipped with such option, would have a **pump package** box. Pic.D.6 below shows general layout of pump packages, used for NG-V model fluid coolers. Note, that the package could be mounted onto the fluid cooler directly (standard) or provided separately.

- **Pump (38)** establishes glycol mixture circulation through the fluid cooler and dehumidifier;
- **Expansion tank (39)** compensates for temperature-based glycol volume fluctuation;
- The pump package **electrical sub-panel (40)** contains the pump package electrical power and control apparatuses.
- The pump package manifolds are usually equipped with pressure gauges, automatic air venting valve, draining and other valves.

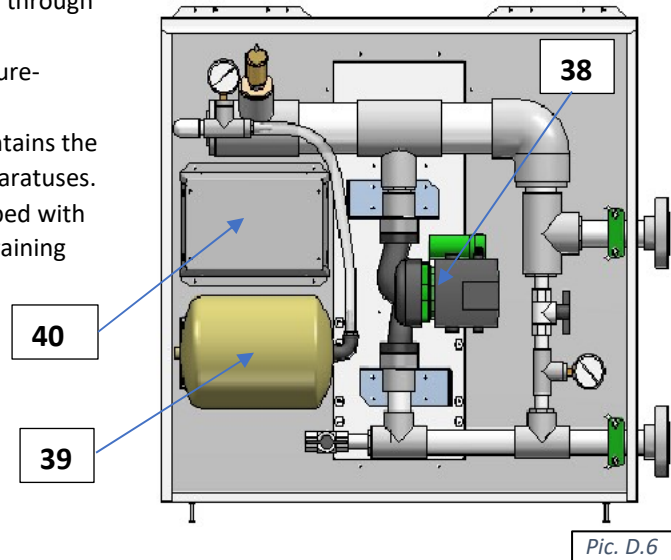

## Sequence of Operation

The dehumidifier's ventilation system establishes the required airflow through the dehumidifier. The control system compares air temperature and humidity to their desired values (set points) and proceeds to dehumidify, cool or heat the recirculating air.

If the dehumidifier is equipped with the pool water heating option, the pool water temperature is compared to its set point and pool heating is provided if required.

### Set Points

The control system is constantly adjusting unit operation to achieve and maintain said parameters within couple degrees/percent of the set point.

Refer to the dehumidifier's main label for the design value of control parameters, as well as the following note.

**Note:** To ensure the dehumidifier's most economical operation, we recommend maintaining the following relationship between pool water and room air temperatures:

$$\text{Room Air T} = \text{Pool Water T} + 2^{\circ}\text{F}$$

### Ventilation.

The **main blower** runs continuously, establishing required supply airflow. The main blower speed is pre-set via adjustable variable signal.

**Minimum Exhaust Fan (EF)**, if dehumidifier is equipped with such option, directs portion of return air outdoors. Like main blower, exhaust fan(s) speed is also controlled via adjustable (pre-set) variable signal, that varies based on scheduled ventilation mode (Occupied, Non-Occupied and Spectator) or call for Economiser Mode (as part of Air Conditioning and/or Dehumidification operation).

**Minimum Outdoor Air (OA) damper**, if dehumidifier is equipped with such option, opens to introduce fresh outdoor air into the premise. OA damper could be equipped with ON/OFF (simple fully open – fully closed) or modulating-controlled actuator; latter one would be controlled same way as minimum exhaust fan.

### Purge (Additional Exhaust) Option.

Along with **Min Exhaust Fan** and **Min Outdoor Air** damper, dehumidifier could have additional set of **exhaust (purge) fan(s)** (PF) and **purge outdoor air damper** (POA), commonly referred as **Purge**. Purge fan(s) and OA damper(s) function is to allow for higher exhaust and fresh air amount, up to complete (100%) air changeover (when all exhaust fans and OA dampers are at their max capacities).

**Purge Fan(s)** and **Purge Outdoor Air** damper(s) are controlled in the same fashion as **min exhaust fans** and **min outdoor air**. Some dehumidifiers may be equipped with additional **Return Air** damper: it closes in event of complete air changeover, separating return air side of dehumidifier from supply side (refer to **Layout and Components** chapter, as needed, for respective devices' location).

Complete air changeover, triggered manually, is known as **Purge Mode**.

- **Note.** Externally installed Exhaust Fan(s) and Outdoor Air damper(s) could be also controlled by the dehumidifier control system. This applies to both, **Minimum** and **Purge/Additional**, fans and dampers.

### Heat Recovery Option.

Dehumidifiers, packaged with Minimum Exhaust Fan and Minimum Outdoor Air damper, could also have additional **Heat Recovery** (HR) closed-loop glycol system.

**Heat Recovery** loop (see Pic. E.1 below) consists of two coils (air-to-glycol heat exchangers) and a pump, establishing glycol circulation between them. One coil, installed at exhaust air opening, recovers portion of exhausted air energy, another coil, installed at outdoor air intake, transfers this captured energy to entering outdoor air.

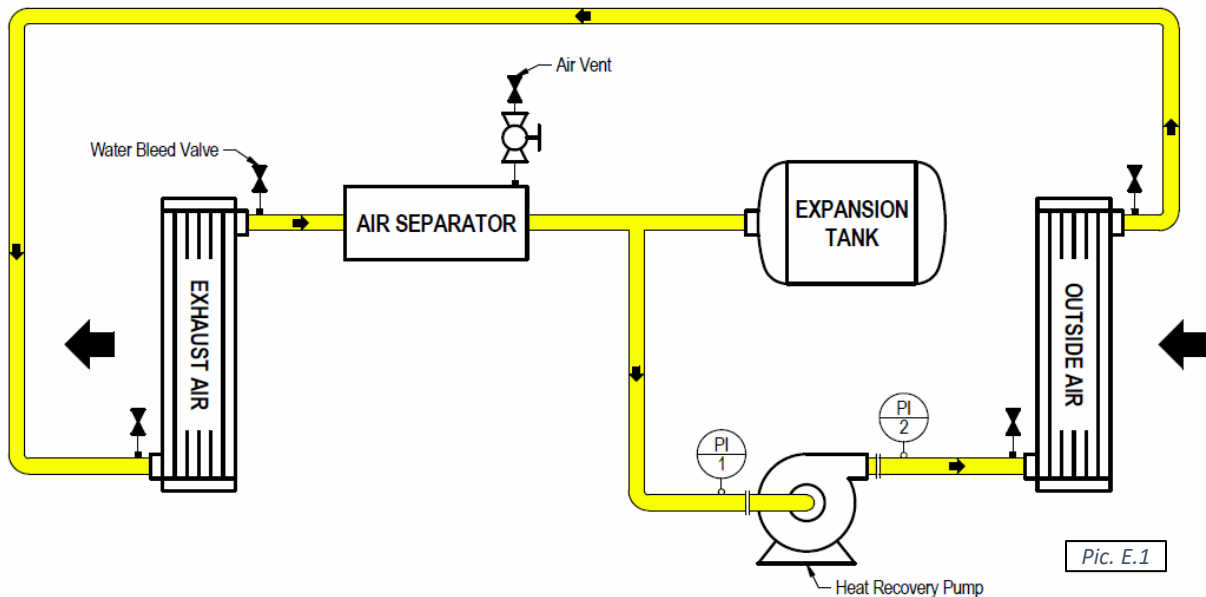

### Space Heating

When premise air temperature drops below the set point, the dehumidifier control system issues a call for Space Heating Mode and engages space heater (electric or gas heater, hot water coil with valve etc.) by sending space heating signal, respective to space heater control type - on/off, variable (0-10VDC), etc.

### Air Conditioning, Dehumidification and Pool Heating.

When premise air temperature goes over (exceeds) its set point, the dehumidifier control system issues a call for Air Conditioning Mode. Respectively, when premise air humidity goes over (exceeds) its set point, the dehumidifier control system issues a call for Dehumidification Mode. In some instances, these calls may co-exist.

To execute Dehumidification or Air Conditioning (Cooling) mode, control system, depending on current conditions, would resort to available means of cooling or dehumidification.

### Economiser Mode Option.

**Note:** Economiser Mode requires dehumidifier to be equipped with full (min and additional) exhaust and outdoor air options!

If outdoor air is dry and/or cool, it could be used to dehumidify and/or cool the premise. In this case, on call for Dehumidification or Air Conditioning mode(s), control system would simply increase exhaust fan(s) speed signal to direct more stale return air outside and bring in more outdoor (dry/cool) air in, thus reducing supply air humidity and/or temperature (as needed).

## Compressor(s)

Whenever the compressor operates, the evaporator is always dehumidifying and cooling the return air. The heat removed from the air at the evaporator, as well as the heat from the compressor's action, must be rejected to one of three heat sinks: room (premise) air, pool water (if applicable) or outdoors. The control system will direct the heat to where it is needed based on room (air and pool water temperature) conditions:

- If room air is needed to be warmed up – more heat is diverted towards reheat coil;
- If pool water is needed to be warmed up – more heat is diverted towards pool heating coaxial heat exchanger (if dehumidifier is equipped with this option).
- Rest of the heat (if any) is diverted towards outdoors (outdoor condenser, fluid cooler, etc.)

## Compressor Circuit Operation

Piping schematic for compressor circuit is shown on Pic. E.1.

When a demand requires the compressor to operate, the following sequence occurs:

- Once blower operation, related safeties and timers are confirmed by the control system, the pump down solenoid valve opens and once pressure stabilizes, the compressor starts.
- Reheat valve diverts portion of hot gas into the reheat coil. Remainder of the hot gas goes into outdoor condenser and (if applicable) pool water heat exchanger.
  - o Dehumidifier with pool heating option: pool valve diverts portion of hot gas into pool water heat exchanger, based on pool water heating demand.
  - o Outdoor condenser fan is engaged only if hot gas is diverted outdoors and compressor pressure is higher than pre-set level (see **Outdoor Condenser and Fluid Cooler Operation** below).
- Once demand for the compressor's operation is removed (respective call is satisfied), the pump down solenoid valve closes; once the compressor suction pressure reaches the pre-set pressure, the compressor stops.

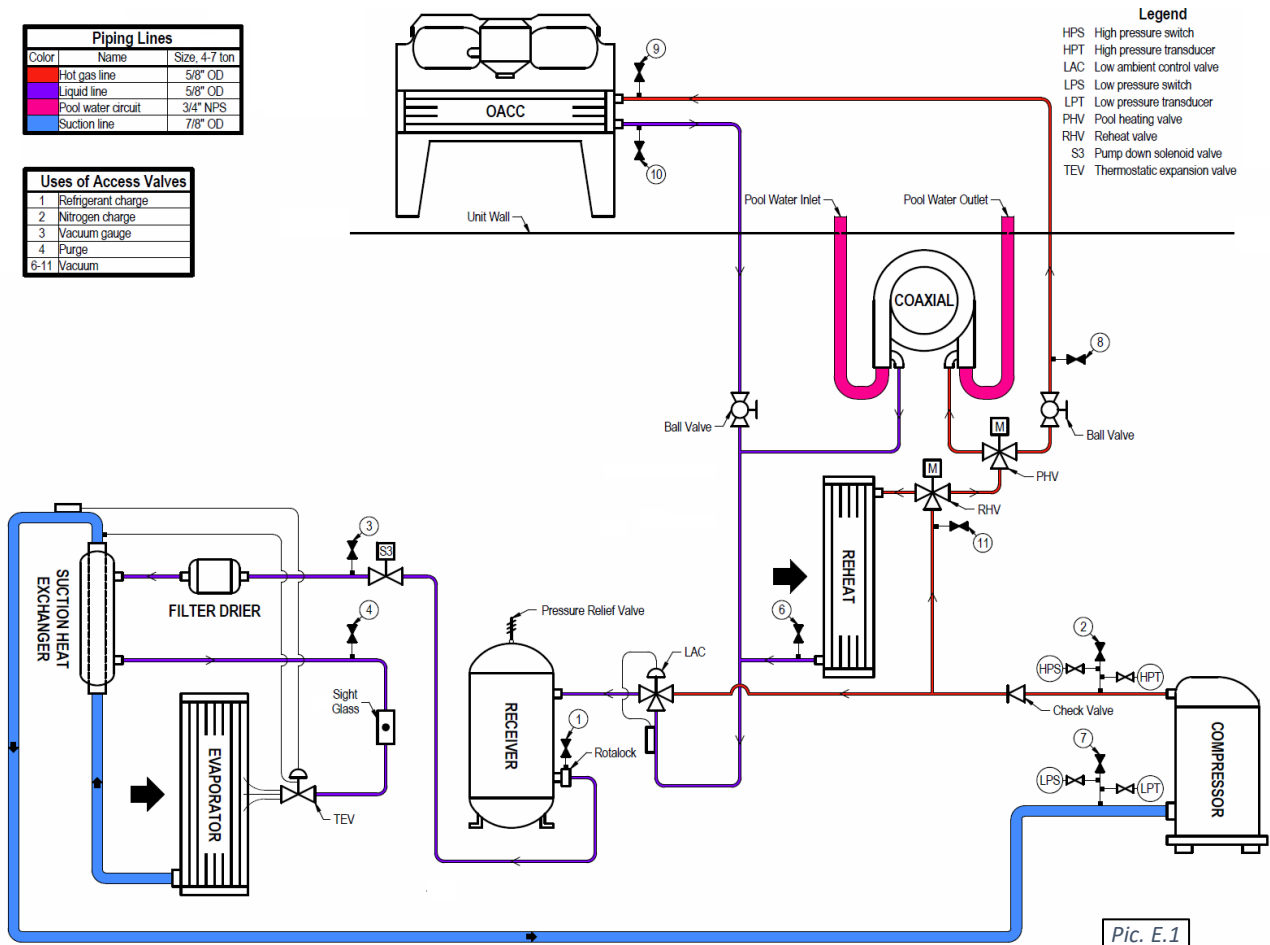

**Outdoor Condenser and Fluid Cooler Operation.**

Based on the type of the outdoor condenser or fluid cooler fans' type (two-speed fans or EC-type/modulating fans), respective signal(s) are sent by control system to engage said fan(s): for two-speed fans - on/off signals (switching speeds, based on compressor head pressure level), for EC-type fans - variable 0-10VDC signal (proportional to the compressor head pressure level). Refer to the fans' type and wiring diagram if/when needed.

If the fluid cooler is equipped with the built-in pump package (to establish cooling fluid flow between dehumidifier and the fluid cooler or to serve as additional/booster pump), the said pump is also engaged along with fluid cooler fans – pump would stay engaged while fans are engaged (regardless of the fans' speed).



## Interface and Communication

### Touch Display Operator Panel

The Touch Display Operator Panel (OP), shown on Pic. F.1, is used as a main interface between the dehumidifier and operator. The same OP can be located in the dehumidifier main electric panel (default; used as a local OP) or installed remotely from the dehumidifier

- **NOTE:** length of CAT5 or CAT6 cable, between remote OP and the dehumidifier MUST NOT exceed 1000'!

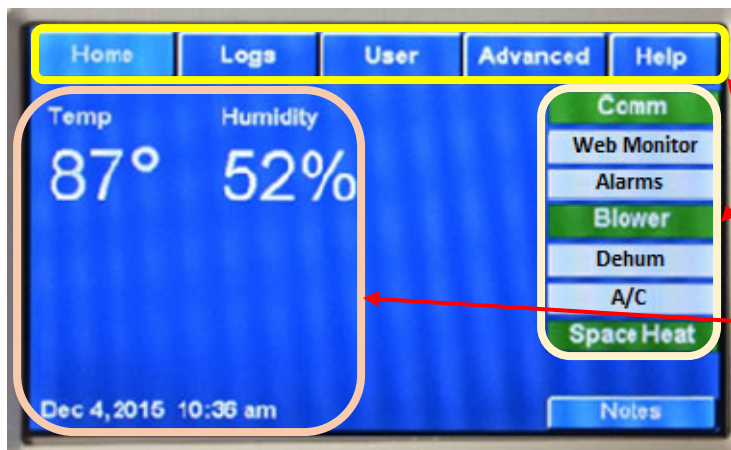

Pic. F.1

Touch Display OP allows to:

Access Touch Display Menus

View dehumidifier current operational statuses (Touch Display Communication, Alarms, dehumidifier operational calls, etc.)

View controlled parameters' values (premise air temperature, humidity and, if applicable, pool water temperature) and current date and time.

#### Touch Display Menus:

Home	Opens/returns to the home page
Logs	Access to dehumidifier logs and log-related features ( <i>Alarms</i> , etc.)
User	Access to user settings ( <i>Setpoints</i> ) and commands ( <i>Stop/Restart</i> Dehumidifier, etc.)
Advanced	Access to advanced settings and features
Help	Context sensitive help presenting information related to the viewed page

#### Most common/basic maintenance tasks performed using Touch Display OP

- ✓ **Adjust Setpoint** – in **User** menu: press the **User** button, then press the **Setpoints** button; select desired parameter (room air temperature etc.) and enter the desired value. Press the **Enter** button to confirm the entered value.
- ✓ **Stop/Restart Dehumidifier** — in **User** menu: press the **User** button, then press the **System Restart** button;
  - To stop and restart dehumidifier, press the **System Restart** button
  - To reboot Touch Display OP, press the **Restart Display** button
- ✓ **Review Alarm records** — done via the **Logs** menu: press the **Logs** button, then press the **Alarm Log** button.
- ✓ **Unlock device/dehumidifier, stopped and currently locked out on the alarm** — done via **Logs** menu: press the **Logs** button, then press the **Current Alarms** button; press the **Clear** button next to the respective alarm (the alarm that's locked out the device or entire dehumidifier).

For detailed information on TouchDisplay OP refer to **DASV Touch Display Manual**, provided with the dehumidifier (or contact factory to obtain a copy).

## Alarms

If the dehumidifier control system detects abnormal or unsafe for further operation situation, it issues **Alarm** (notification of such situation accompanied by respective component or entire dehumidifier stoppage and/or lockout) or **Alert** (notification of minor abnormal situation without any devices' stoppage or lockout).

All alarms and alerts are recorded and can be viewed/cleared via the Touch Display OP:

- ✓ Viewed: to facilitate troubleshooting and addressing abnormal situation
- ✓ Cleared: to unlock stopped device or entire dehumidifier and allow for further operation

The table F.1 below lists the basic alarms with their descriptions and recommended initial troubleshooting.

Table F.1. Most Common Alarms/Alerts		
Alarm	Alarm Description	Check
No Air	No air flow (air flow switch fault – <i>if air flow switch is installed</i> )	Check main blower operation and air flow switch
Blower OL	Main Blower overload/safety fault	Check main blower operation and its LED light blinking pattern.
Fire	Fire/smoke detector fault – <i>if detector is installed externally and connected to control board</i>	Check external fire/smoke detector/system
Freeze	Supply Air temperature is lower than Freezestat Setting (default: 45 F)	Check SA temperature readout, space heating system operation
Filter	<u>Alert</u> , indicating that filter change timer has lapsed – <i>if timer is activated</i>	Clear the Filter alarm and cancel filter scheduler if not in use.
VM	Voltage Monitor fault – power supply (phasing, voltage etc.) is outside of pre-set limits	Check Voltage Monitor info/status, incoming power (voltage)
<b>Compressor:</b> - HP1-(X) - LP1-(X) - SupHeat1 - DisTemp1	Various compressor-related alarms, relevant to: - Compressor high/discharge pressure; - Compressor low/suction pressure; - Compressor superheat/suction temperature;	Check respective compressor-related data (pressure and temperature readouts), refrigerant level in the receiver's sight glasses, cleanliness of air-side coils and air filters.
<b>Pool Water:</b> Water(X)1, Wtr(X)1	Various compressor pool water heating-related alarms indicating inadequate (too low/too high) pool water flow and/or pool water temperature.	Unless the alarm occurred due to a known water flow interruption (backwash, etc.), check the pool water flow (pump, filters, valves) and pool water temperatures.
HPRelief	<u>Alert</u> , indicating that additional condensing capacity is engaged (pool water heat exchanger etc.) to prevent compressor high pressure from rising too high.	No action required unless it's accompanied by other (compressor-related) alarm or faulty situation.

- ✓ Note that proper and regular maintenance (example: keeping air filters and air-side coils clean) should reduce the chances of abnormal operations, dehumidifier alarm-related stoppages and downtime.



**CAUTION!** We recommend you have a qualified professional investigate and remedy all reoccurring alarm-related stoppages and lock-outs. Continuous dehumidifier restarting (clearing alarms) without addressing actual issues may result in equipment malfunction, premature wear, and failure.

For more details regarding alarms and alerts, refer to the **Alarms Description** information (available via Help feature in Touch Display OP); contact factory if needed.

## WebSentry ©

Your Seresco dehumidification equipment can connect to our proprietary web-based remote monitoring tool, WebSentry ©, for worry-free operation of your dehumidifier, including scalable offerings and opportunities to streamline any facilities operation. WebSentry © provides a platform for monitoring, data collection, \*factory parameter adjustment, and notifications. Some WebSentry © remote monitoring features are included for a period of 2-years, starting either from Factory Startup Date or 6 months from Ship Date, whichever comes first.

***For More Information - Contact Factory Support at 1.833.327.7665***

## Establishing Remote Communication / Connectivity

To establish WebSentry © connection, the dehumidifier must communicate with the factory server via a reliable internet connection. The dehumidifier is designed to operate as a self-controlled device (not requiring any external control). There are options to achieve this communication beyond the included solution that can be added (if required). The options (included/ alternative) are listed below with specific details and requirements.

- Your dehumidifier's included wireless cellular connectivity device will provide a direct, stable, and secure access point without the need to run a physical Ethernet cable from your local network hub to the unit, or to connect the unit to your building's wireless network through your firewall. This method generally requires no additional installation (location dependent).
  - o The Ethernet cable will come pre-connected *\*on most machines*
  - o Relocation of the wireless cellular connectivity device may be required, and materials are included
    - An Ethernet cable will have to be ran from the device to the RJ-45 connector on the sub-board. (sub-board, called Core Module, is located on the main control board in the main electric panel) – see Pic. F.2.
- Connect the dehumidifier to a local network switch, wireless AP device (providing connection to a local network):
  - o Plug an Ethernet cable into the sub-board Ethernet RJ-45 jack (sub-board, called Core Module, is located on the main control board in the main electric panel) – see Pic. F.2.
    - **Note:** An array of RJ-45 jacks (plastic, black either banded **Yellow** or **Red**) mounted on the control board directly, for Touch Display & Expansion connection. Make sure to use the proper RJ-45 jack (metal-surface one, located directly on the sub-board) for WebSentry © connection. *\*See picture below / right for examples*
- *Configure, as needed, local server and dehumidifier network settings.*

## BMS (Building Management System)

Communication to BMS can also be supported, depending on the type of communication protocol said BMS utilizes.

The equipment control software supports most common of them - different control software variation might be required to support different BMS communication protocols. Contact factory if necessary.

**BACnet (MSTP).** Communication is established via the connection points on J8 Pins 5&6

✓ BACnet MSTP and WebSentry © communication can be used simultaneously.

**BACnet (Internet, IP).** Communication is established via the Ethernet cable (same method as Web Monitor).

✓ BACnet and WebSentry © communication can be used simultaneously.

**LON or Modbus.** Communication requires external wiring between dehumidifier main control board and BMS terminal. Wiring schematic is normally indicated on wiring diagram (provided with dehumidifier).

✓ If dehumidifier is equipped with LON communication option, it is normally provided with pre-wired LonWorks Gateway for communication purposes.

For more information about WebSentry © or BMS communication setup (connection, configuration, access, point cutsheets, etc.) – contact factory support (**1.833.327.7665**).

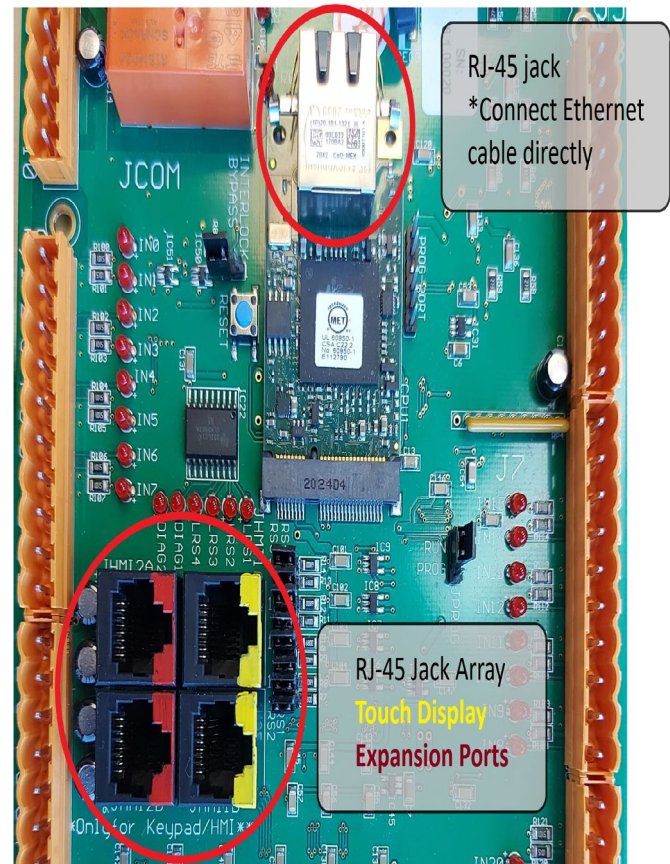

## Cellular Device Lay-out / Panels

The accomplish connectivity the device offers an array of connection ports. The LAN1 port (as indicated) is used for command center connectivity.

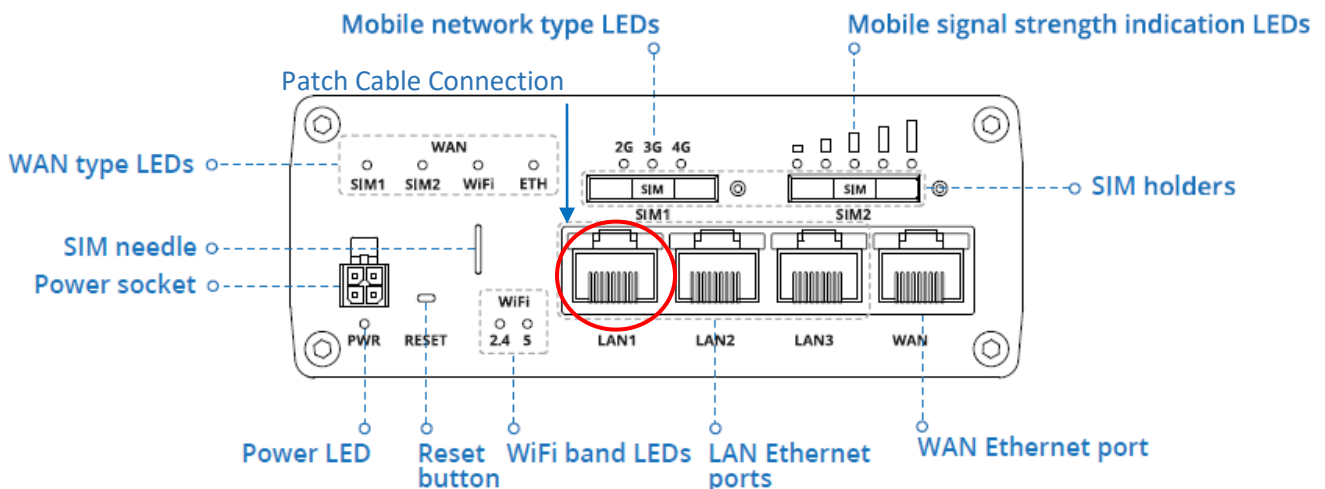

## Connection Panel

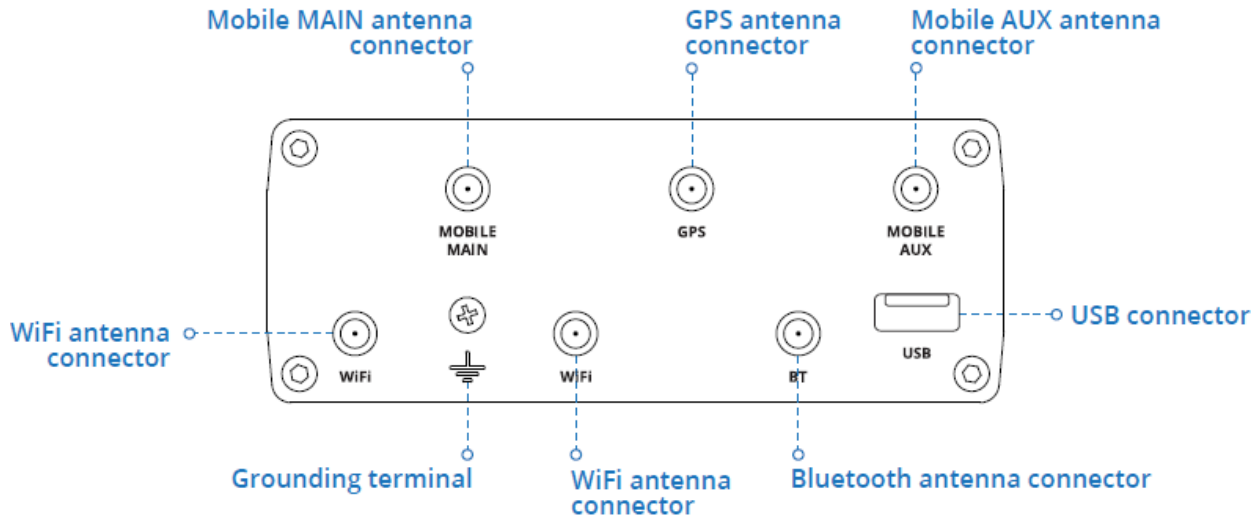

Antenna Panel

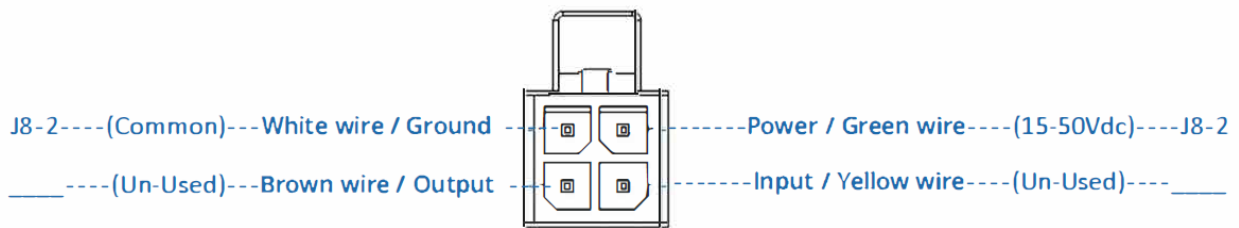

Power Cord Pinout (15-50VDC)

Board Connection (24VDC)	Adapter Connection (120V)	Molex Plug
J8-1	Red Wire	Green Wire / Upper Right
J8-2	Black Wire	White Wire / Upper Left

*\*Lower plug pins are unused*

### LEDs / Connectivity

The connection panel also incorporates a wide array of indicator LEDs, each having a specific use. The LEDs and their indications are listed in the following tables for troubleshooting purposes.

LED	Indicator	State
<b>PWR</b>	ON / OFF	Power / NO power
<b>Wi-Fi</b>	2.4 On/Off, 5 On/Off	Access Point running / No access point
<b>WAN</b>	SIM1/2, Wi-Fi, ETH	Indicator On/Off – Service active / Service inactive
<b>Ethernet</b>	Orange / Green LEDs (Blink = Data)	Orange – 10/100 Mbps, Green – 1000Mbps connection
<b>Mobile Type</b>	2G, 3G, 4G LEDs	LED illuminated – Network Active
<b>Mobile Signal</b>	Power Bars	Bar illuminated = Strength level

## Antenna Information

The cellular connection device is equipped with an assortment of antennas (labeled) to provide several levels of connectivity. Each antenna must be installed onto the device via its identified SMA male connector. In certain cases, a remote antenna may be required to achieve an acceptable signal. The ranges and specifications of the antennas is listed below.

Antenna type	Frequency range	Impedance	VSWR	Gain*	Radiation	Connector
<b>Mobile</b>	800~960 MHz, 1710~2690 MHz	50 $\Omega$	$\leq 3.0$	$\leq 4$ dBi	omnidirectional	SMA male
<b>Wi-Fi</b>	2.4~2.5 GHz, 5.10~5.95 GHz	50 $\Omega$	2.5 max	$\leq 3.5$ dBi	omnidirectional	RP-SMA male
<b>BLE</b>	2.4~2.5 GHz	50 $\Omega$	$\leq 2.5$	$\leq 2.5$ dBi	omnidirectional	RP-SMA male
<b>GNSS</b>	1575.42~1602 MHz	-	2.0 max	28 dB + 1.5/-3 dB	RHCP polarization	SMA male

## Basic Maintenance

Although Seresco equipment is built for minimal service downtime, periodic preventative maintenance is required to ensure maximum reliability, safety, and operating efficiency.

 **WARNING!** To ensure equipment longevity and proper and efficient operation, the dehumidifier and its auxiliary systems and devices (outdoor condenser, fluid cooler, boiler package, etc.) **must be maintained** properly and regularly. It is recommended to create a **facility-specific Routine Maintenance Program**. Failure to maintain the equipment properly and regularly could result in personal injury, equipment damage or malfunction and will void the equipment warranty.

### Maintenance and Safety

Only qualified/properly trained personnel should attempt to perform respective maintenance tasks.

- When it is necessary to work with live electrical components, have a licensed electrician or other qualified professional perform the required task.
- **Be properly trained and equipped.** Some maintenance tasks may involve usage of power tools, chemicals, etc. Refer to such tools and materials data (manuals, MSDS, etc.). Personnel performing such maintenance tasks should be:
  - Properly trained to handle such tools and materials safely
  - Equipped with proper personal protective equipment
- **Turn the power off.** Before performing any maintenance, disconnect all electrical power, including remote disconnect, and discharge all energy storing devices (VFDs, etc.) before servicing. Follow proper lockout procedures to ensure that power cannot be accidentally restored. Failure to follow provided safety warnings and labels could result in serious injury or death.
- **Be aware of potential hazards.** The equipment contains moving mechanical parts, components under high refrigerant pressures and surfaces with high temperatures. Before entering the dehumidifier and/or performing any equipment maintenance work, make sure that all moving parts are stopped, and it is safe to perform required task.

### Maintenance Key Points

Here are some basic/key maintenance considerations, pertinent to all dehumidifiers and their auxiliary systems:

- Dehumidifier in mechanical room. **No chemicals** should be stored **in the same mechanical room** where the dehumidifier is installed. Chemical fumes/off-gas can cause premature deterioration of the equipment.
  - Store chemicals in a separate, well-ventilated room.
- Access to the Equipment. Ensure that the **equipment is accessible** (minimum clearances are maintained): approaches to the dehumidifier are not restricted/limited with materials in mechanical room (indoor installed) or with snow (outdoor installed dehumidifiers, OACC and O AFC).
- “MUST DO” maintenance task. Although all other maintenance tasks are as important, these two maintenance tasks are the most common and most helpful:
  - Maintain **clean air filters** (return, outdoor air filters, etc.). Make sure to replace dirty filters regularly.
  - Maintain **clean air-side coils** (especially Outdoor Condenser or Fluid Cooler). Make sure to clean coils regularly.

- **Pool Water Chemistry.** Incorrect pool water chemistry (improper pH level or high concentration of chlorine, sea salt or other corrosive additives etc.) can result in equipment premature wear or malfunction (let alone poor air quality in the pool and potential health issues) and will void the equipment warranty. Refer to pool water quality standards; contact factory as needed.

### Routine Maintenance Program

Creating facility-specific routine maintenance program and following it is vital to equipment longevity and efficient operation.

The suggested general maintenance operations and their frequency/intervals, listed in the table M-1 below, can be used to create such a program. For more detailed maintenance recommendations related to specific components, refer to the respective component manufacturer’s manual.

Table M.1. Recommended Maintenance Tasks and Intervals	
Interval	Maintenance Task
Weekly	Observe the equipment for any changes in running conditions and unusual noise
Quarterly	Clean or replace air filters if clogged or dirty
	Verify that all set-points are correctly programmed as specified by the facility operator
Semi-Annually	Inspect and clean the drain pan(s)
	Tighten electrical connections, if required
	Check and tighten, if required, pool water hose clamps and sensor mounts
	Inspect all airside coils (outdoor condenser, fluid cooler, dehumidifier coils – evaporator, etc.) for dirt, cobweb build-up, etc.; clean as needed
	Check that the P-trap is primed (filled with water). It is good practice to pour some water into the drain pan to ensure that the P-trap is primed and operational
	Check the outdoor air louvres and dampers for accumulation of dust and clean as required
	Inspect the equipment’s cabinet for corrosion. If any damage is found, clean and repaint the affected surface with a rust-resistant primer
Annually	Clean the fan wheel(s)
	Check dampers operation (linkage/actuator is not loose, damper opens/closes properly etc.)
	Inspect electrical components, wiring and insulation
	Rotate the fan wheel(s) and check for obstructions and rubbing
	Check gasket condition on all doors to ensure an airtight seal
	Check bolts on compressors, motor mounts, dehumidifier bases and coils and tighten if required
	Verify that the airflow around the remote condenser or dry cooler is unobstructed



## Specific Components Maintenance

Actual maintenance plan may vary from installation to installation, yet there are several key components from maintenance prospective.

If needed, contact respective component manufacturer for additional maintenance information.

### Filters

- Ensure air filters are clean. Dirty air filters will negatively affect dehumidifier performance and lifetime
- Frequency of filters replacement will vary based on air quality, dehumidifier usage, facility type, etc. Make sure to replace filters regularly
- Replace with filters of equivalent size and rating – refer to dehumidifier details (compartment stickers, etc.)

### Insulation

Inspect dehumidifier insulation, exposed to airstream for microbial growth (i.e., mold). If there is evidence of microbial growth on the interior insulation, the insulation should be removed and replaced prior to operating the dehumidifier.

### Air-Side Coils

- **Warning: Hazardous chemicals!** Cleaning agents can be highly acidic or alkaline. Handle all chemicals carefully and use appropriate personal protective equipment (PPE). Refer to the cleaning agent manufacturer's Materials Safety Data Sheet (MSDS) for safety and handling information. Failure to follow all safety instructions could result in serious injury or death.
- **Warning: Hazardous pressures!** Coils containing refrigerant under pressure must not be cleaned using a solution over 150 °F. Failure to follow these safety precautions could result in coil bursting, which could result in serious injury or death.

### To clean the coil

- Disconnect all electrical power to the equipment
- Use a soft brush to remove loose debris from the coil
- Mix a high-quality coil cleaning detergent with water according to the manufacturer's instructions
- Clean coil according to suggested instructions
- Thoroughly rinse both sides of the coil and the drain pan with, clean water
- Straighten any coil fins that have been bent during the cleaning process
- Confirm the drain line is clear
- Replace all panels and parts and restore electrical power to the equipment

### ***Special Maintenance Tasks. Fluid Cooler Winterization.***

Normally fluid coolers are used in the systems, filled with glycol mixture to prevent the system and the fluid cooler from freezing and, potentially, rupturing, when exposed to temperatures below freezing point.

When fluid cooler is used with media that, when exposed to low temperatures, could freeze (water or lower-percentage glycol mixture), one way to protect the equipment is to drain it (also known as “winterization” of the equipment).

Though fluid cooler itself is normally equipped with means to be drained properly/fully, it is recommended to have same means in place for entire system (fluid cooler – piping – dehumidifier etc.):

- Have each local high point of the system equipped with means to bleed the air (air bleeding valve etc.)
- Have each local low point of the system equipped with means to drain the fluid.

 **CAUTION.** Draining and re-filling the fluid cooler must be performed by trained personnel, according to proper field practice and system layout. Improper draining or re-filling the system could lead to equipment damage, malfunction, premature tear and ware and may void equipment warranty.

 **CAUTION.** Ensuring that the fluid cooler and associated system(s) equipped with proper means of draining, creating draining and re-filling procedures as well as determining whether draining is warranted to protect the equipment is outside of manufacturer’s scope and is a responsibility of installing contractor and local maintenance team.

## Pools – Equipment Warranty

### General Policy

All Seresco service and warranty work is managed exclusively by Dehumidified Air Services (DASV). All warranties apply to the original equipment owner and are not transferable. All warranty inquiries should be made to Dehumidified Air Services.

#### Dehumidified Air Services:

Phone: 1-833-327-7665 Email: [Warranty@DehumidifiedAirServices.com](mailto:Warranty@DehumidifiedAirServices.com)

Seresco warrants as set forth and for the time periods shown below that it will provide through either a DASV Service Technician or an authorized service organization specified and approved by DASV, a new or rebuilt part to replace a factory installed part which has failed because of defect in workmanship or material.

**NOTE: EVERY REQUEST RELATED TO WARRANTY OF ANY NATURE AS DESCRIBED BELOW MUST BE OFFICIALLY AUTHORIZED AND DOCUMENTED IN ADVANCE BY DASV TO QUALIFY FOR WARRANTY COVERAGE.**

### Warranty Void Unless Registered

All Warranties are void unless the start-up of the equipment is approved by a DASV service technician. Upon completion of the start-up, a “Warranty Registration Certificate” will be issued, along with the Start-Up Report, which activates the Warranty Period of the equipment. The Warranty Period will commence either upon completion of start-up registration of the equipment or 6 months from factory ship date, whichever comes first.

### Initial 90-Day Comprehensive Warranty

During the first 90 days from initial start-up, all parts and repairs related to factory defects or replacement parts are covered by the Seresco manufacturer warranty. All parts and labor requirements will either be handled by DASV technicians directly or managed and approved in advance by DASV through DASV authorized technicians.

### Internet Connected, Conditional One Year Repair Warranty

If and only if the equipment is connected to the internet from the date of the warranty activation, a Repair Warranty will be provided for an additional 9 months subsequent to the initial 90-Day Comprehensive Warranty for a total of 12 months of parts and labor warranty coverage. The unit must be connected and communicating to Seresco WebSentry for the entire term from start-up in order to qualify.

If qualified, Seresco will provide or pay for the required part and direct labor only, related to the part replacement. Only the labor required to replace the defective part is under warranty for this 9-month extension. Travel time, diagnostic time, per diems, truck charges, shipping charges etc. are not covered under this Conditional Repair Warranty.

### Two-Year Parts Warranty

If any factory installed part supplied by Seresco fails because of a defect in workmanship or material, prior to the completion of the 24<sup>th</sup> month from date of completion of the warranty activation, Seresco will provide a new or rebuilt part F.O.B. our factory. No labour reimbursement will be made for expenses incurred in replacing the part except as set in the *Initial 90-day Comprehensive or Internet Connected Conditional One-Year Repair Warranty*.

Seresco reserves the right to have the defective part returned to the factory in order to determine the warranty applicability. Parts shipping and handling costs (to and from the factory) are not covered outside of the *Initial 90-day Warranty*.

## Replacement Part Warranty

If a replacement part provided by Seresco under this warranty fails due to a material defect prior to the end of the Two-Year Parts Warranty (or the end of the extended warranty period if applicable), whichever comes first, Seresco will provide a new or rebuilt part F.O.B. factory.

## Applicability

This warranty is applicable only to products that are purchased and installed in the United States and Canada. This warranty is NOT applicable to:

1. Products that have become defective or damaged as a result of non-DASV or unauthorized service work, poor maintenance, faulty electrical supply, act of God, or any other circumstances outside of the specified care, maintenance or operation of the equipment including:
  - Components that have been relocated from their original placement during manufacturing.
  - Any portion of the system not supplied by Seresco.
  - Components on which the model and/or serial number plates have been removed or defaced.
  - Components which have become defective or damaged as a result of unauthorized opening of the refrigeration circuit, improper wiring, electrical supply characteristics, poor maintenance, accidents, transportation, misuse, abuse, fire, flood, alteration and/or misapplication of the product.
  - Products not installed, operated and maintained as per the Seresco Operating and Maintenance Manual.
  - Products on which payment is in default.
2. Parts that wear out due to normal usage such as; air filters, fuses and sensors are not covered by this warranty.

NOTE: Refrigerant lost during the *Initial 90-day Comprehensive or Internet Connected Conditional One-Year Repair Warranty* will be reimbursed in accordance to the current market price of refrigerant at the time of repair and upon discretion of Customer Support team. Seresco will not be responsible for refrigerant lost from the system due to improperly installed contractor piping to the remote outdoor air-cooled condenser.

## Limitations

1. DASV is a Manufacturer Service organization, not a first-response or urgent response local service company. As such, we highly recommend that equipment owners have a relationship with their own qualified first response service organization or one recommended by DASV.

DASV hours of operation are from 8:00 AM to 6:00 PM Monday through Friday, unless otherwise agreed to under a separate agreement.

Parts replacement can be subject to availability. We highly recommend for mission-critical applications that owners purchase and maintain a local stock of critical components in case immediate replacement be required. If for any reason one of those components is replaced under applicable warranty conditions, Seresco will reimburse the original cost of any component used under terms of Warranty.

NOTE: Seresco expressly disclaims any liability for parts replacement delays due to parts unavailability or shipping delays.
2. This warranty is given in lieu of all other warranties. Anything in the warranty notwithstanding, any implied warranties of fitness for particular purpose and merchantability shall be limited to the duration of the warranties described above. Seresco expressly disclaims and excludes any liability for consequential or incidental damage for breach of any express or implied warranty.

Where a jurisdiction does not allow limitations or exclusions in a warranty, the foregoing limitations and exclusions shall not apply to the extent of the legislation, however, in such case the balance of the above warranty shall remain in full force and effect.

This warranty gives specific legal rights. Other rights may vary according to local legislation.

### **Force Majeure**

Seresco will not be liable for delay or failure to provide warranty service due to government restrictions or restraints, war, strikes, material shortages, acts of God or other causes beyond Seresco control.

### **Optional Extended Warranties**

If purchased prior to shipment and documented with a registered extended warranty statement certificate, Seresco will provide replacement components within the specified period of the extended warranties. Extended warranties commence either upon completion of start-up registration of the equipment or 6 months from factory ship date, whichever comes first, and cover parts replacement only for parts that fail as a result of manufacturing defect. The failed parts must be returned to the factory with transportation prepaid by the customer as a condition of these warranties. Optional extended warranties are for parts only and subject to all the terms of the Two-Year Parts Warranty.

#### **1. Optional Five-Year Compressor Warranty**

Subject to the terms above, Seresco will provide a replacement compressor for up to 60 months from the date of the warranty activation.

#### **2. Optional Five-Year Dehumidifier Coil Warranty**

Subject to the terms above, Seresco will provide a replacement coil for up to 60 months from the date of the warranty activation. Extended coil warranties are for parts of the dehumidifier only and does not cover parts of dry cooler or OACC coils.

#### **3. Optional Ten Year Dehumidifier Coil Warranty**

Subject to the terms above, Seresco will provide a replacement coil for up to 120 months from the date of the warranty activation. Extended coil warranties are for parts of the dehumidifier only and does not cover parts of dry cooler or OACC coils.

#### **4. Optional Five-Year Driveline Warranty**

Subject to the terms above, Seresco will provide driveline replacement parts for up to 60 months from the date of the warranty activation.

Driveline Components Include:

- Supply fan motor
- Exhaust fan motor (including Min Exhaust and Purge Exhaust motors)
- Heat recovery loop pump
- Compressor glycol/water pump
- Dry cooler/outdoor condenser fan(s)
- Dry cooler pump(s)